

# O4A

## ONE-TIME-USE SCREWED AND BONDED PLUG

*A robust, tamper-proof rupture disc plug ideal for **safety critical applications** such as **industrial gas handling** or **cryogenic applications**.*

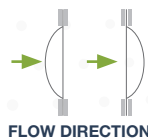

Our O4A component combines a brass body as standard with either a stainless steel or nickel disc, depending on burst pressure and process requirements. The forward- or reverse-acting rupture discs are torqued and clamped between the inlet and outlet. The robust rupture disc plug offers a cost-effective and maintenance-free solution.

We use an approved thread-locking fluid to prevent tampering. The plug offers a range of thread forms and combinations of male or female baffle and through connections to suit varying specifications.

O4A is available with our innovative burst detection system, OE-Tel. OE-Tel is the first ATEX-approved burst detection system for OEM rupture disc components. With a fail-safe design, OE-Tel is not affected by downstream pressure fluctuations or corrosion.

<b>Standard disc sizes</b>	15, 19, 25, 40 mm
<b>Standard thread sizes</b>	1/8", 1/4", 3/8", 1/2", 3/4", 1"
<b>Standard thread types</b>	NPT, BSPT, BSPP
<b>Burst Pressure</b>	1 - 70 barg
<b>Operating Ratio</b>	Reverse: 90% / Forward: 85%
<b>Performance Tolerance</b>	+/- 5%
<b>Manufacturing Range</b>	0%

**Let us help you with all your pressure relief questions.**

**UK office** | North Shields  
+44 (0)191 293 1234 | [uksales@osecoelfab.com](mailto:uksales@osecoelfab.com)

**US office** | Broken Arrow  
+1 (918) 258 5626 | [info@osecoelfab.com](mailto:info@osecoelfab.com)

[osecoelfab.com](http://osecoelfab.com)

**REQUEST A QUOTE FOR THE O4A** →



# TECHNICAL SPECIFICATIONS



Standard disc sizes*	15mm, 19mm, 25mm, 40mm
Disc type	Forward acting (tension loaded) or reverse acting (compression loaded)
Disc connection to body	Bonded between inlet & outlet (Screwed and bonded with 'Loctite' 290 threadlocker)
Standard thread sizes*	1/8", 1/4", 3/8", 1/2", 3/4", 1"
Standard inlet thread types*	NPT, BSPT or BSPP (male or female) – Left- or right-handed
Standard outlet thread types*	Baffle or through
Burst pressure range	1 barg – 70 barg (14.5 psig – 1,015 psig)
Temperature range	-20°C to 150°C (-4 to 302°F)
Standard materials	Disc: 316 Stainless Steel, Nickel Body: Brass
Max. Operating Ratio	Reverse-acting disc: 90% of minimum burst pressure (1 barg – 200barg) Forward-acting disc: 85% of minimum burst pressure (55barg – 200barg)
Performance Tolerance	+/-5%
Manufacturing Range	0%
Fragmentation	May fragment, depending on design
Vacuum Service	Withstands full vacuum (14.7 psi) and back pressure
Fluid compatibility	Reverse-acting disc: Gas, vapour Forward-acting disc: Gas, vapour, liquid
Leak tightness	Leak-tight: Helium leak-tested to 1x10 <sup>-5</sup> cc-atm/sec
Design Standards	Designed to meet ISO 4126-2:2019 and PED 2014/68/EU

## Certifications

CE

## Related Products

### Sensors

OE-Tel

### Rupture Disc Plugs

OE2

OE5

OE6

# Burst Pressure Ranges

O4A Min/Max Burst Pressure @ 15-30° C / 59-86° F



SIZE		DISC MATERIAL *	REVERSE ACTING DISC (compression loaded)		FORWARD ACTING DISC (tension loaded)	
DN (mm)	inches		MIN barg (psig)	MAX barg (psig)	MIN barg (psig)	MAX barg (psig)
15	0.5	316 Stainless Steel Nickel	4 (58) 3.3 (44)	55 (800) 55 (800)	55 (800) 35 (508)	70 (1015)
19	0.75	316 Stainless Steel Nickel	4 (58) 2.5 (37)	40 (580) 40 (580)	45 (653) 27 (392)	70 (1015)
25	1	316 Stainless Steel Nickel	2 (28) 1 (14.5)	55 (800) 40 (580)	34 (493) 21 (305)	70 (1015)
40	1.5	316 Stainless Steel Nickel	2 (28) 1 (14.5)	55 (800) 40 (580)	20 (290) 13 (190)	70 (1015)

*\*All with brass plug*

# Schematic Drawings: Standard O4A Assemblies

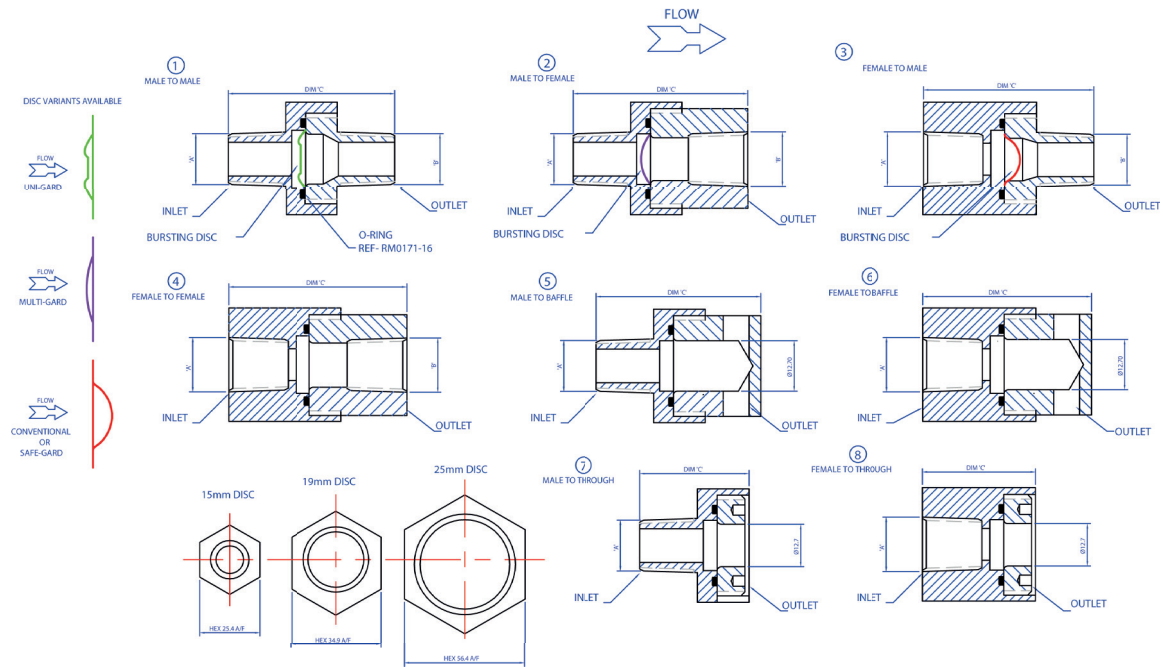

Face to face (Dim 'C' mm)

PLUG CONFIGURATION			15mm				19mm			25mm		
Item	Inlet	Outlet	1/4" NPT/BSPT Dimension 'A'	1/4" BSPP Dimension 'A'	3/8" NPT/BSPT Dimension 'A'	3/8" BSPP Dimension 'A'	1/2" NPT/BSPT Dimension 'A'	1/2" BSPP Dimension 'A'	3/4" NPT/BSPT Dimension 'A'	3/4" BSPP Dimension 'A'	1" NPT/BSPT Dimensions 'A'	1" BSPP Dimensions 'A'
1	Male	Male	51.5	47.5	51.5	47.5	61.5	47	59	52	73	63.5
2	Male	Female	48.5	47	48.5	47	53.5	46.5	54	52	65.5	60.5
3	Female	Male	50	47.5	50	47.5	61	53.5	54	49	65.5	61
4	Female	Female	47	47	47	47	53	53	49	49	58	58
5	Male	Baffle	39.5	38	39.5	38	44.5	37.5	49	47	61.5	56.5
6	Female	Baffle	38	38	38	38	44	44	44	44	54	54
7	Male	Through	30.5	29	30.5	29	28.5	28.5	37	35	45	40
8	Female	Through	29	29	29	29	35	35	32	32	37.5	37.5

Free Flow Area (mm<sup>2</sup>)

PLUG CONFIGURATION			15mm				19mm			25mm		
Item	Inlet	Outlet	1/4" NPT/BSPT Dimension 'A'	1/4" BSPP Dimension 'A'	3/8" NPT/BSPT Dimension 'A'	3/8" BSPP Dimension 'A'	1/2" NPT/BSPT Dimension 'A'	1/2" BSPP Dimension 'A'	3/4" NPT/BSPT Dimension 'A'	3/4" BSPP Dimension 'A'	1" NPT/BSPT Dimensions 'A'	1" BSPP Dimensions 'A'
1	Male	Male	28.26	28.26	70.8	70.8	126.6	126.6	486.3	486.3	506.4	506.4
2	Male	Female	28.26	28.26	70.8	70.8	126.6	126.6	286.3	286.3	506.4	506.4
3	Female	Male	28.26	28.26	70.8	70.8	126.6	126.6	314	314	518.4	518.4
4	Female	Female	70.8	70.8	70.8	70.8	126.6	126.6	314	314	518.4	518.4
5	Male	Baffle	28.26	28.26	70.8	70.8	126.6	126.6	301.4	301.4	471	471
6	Female	Baffle	70.8	70.8	70.8	70.8	126.6	126.6	301.4	301.4	471	471
7	Male	Through	28.26	28.26	70.8	70.8	126.6	126.6	286.3	286.3	506.4	506.4
8	Female	Through	70.8	70.8	70.8	70.8	126.6	126.6	314	314	518.4	518.4

Maximum installation torque (Nm)

PLUG CONFIGURATION			15mm				19mm			25mm		
Item	Inlet	Outlet	1/4" NPT/BSPT Dimension 'A'	1/4" BSPP Dimension 'A'	3/8" NPT/BSPT Dimension 'A'	3/8" BSPP Dimension 'A'	1/2" NPT/BSPT Dimension 'A'	1/2" BSPP Dimension 'A'	3/4" NPT/BSPT Dimension 'A'	3/4" BSPP Dimension 'A'	1" NPT/BSPT Dimensions 'A'	1" BSPP Dimensions 'A'
1-8	All	All	30	30	40	40	50	50	60	60	70	70