

# LoKr™

## TECHNICALLY ADVANCED LOW $K_R$ BURSTING DISC

*The highly engineered bursting disc design offers the **widest bore opening possible on burst, allowing you to use smaller pipe diameters to reduce cost with no compromise on performance.***



Delivering a best-in-class Flow Resistance Factor (FRF) or  $K_R$ , the LoKr is designed to improve process performance and efficiency. The advanced design maximizes performance in three areas: keeping pressure drops in relief lines to a minimum, delivering maximum reliability, and being suitable for the widest range of pressures, temperatures, and line sizes possible.

The dimple design enables full-bore opening with exceptionally accurate burst ratings. This supports operational efficiency, especially at low flow rates, and makes it easier to keep pressure drops across the relief line below 3%.

<b>Size</b>	25mm - 300mm
<b>Burst Pressure</b>	0.69 - 172.3 barg
<b>Temperature</b>	-84°C to 538°C
<b><math>K_R</math> Value (<math>K_{RGL}</math>)</b>	0.22
<b>Operating Ratio</b>	95%
<b>Performance Tolerance</b>	+/-5%
<b>Manufacturing Range</b>	0%

Let us help you with all  
your pressure relief questions.

**UK office** | North Shields  
+44 (0)191 293 1234 | uksales@osecoelfab.com

**US office** | Broken Arrow  
+1 (918) 258 5626 | info@osecoelfab.com

[osecoelfab.com](http://osecoelfab.com)

REQUEST A QUOTE FOR  
THE LoKr



# TECHNICAL SPECIFICATIONS



Size range	25-300mm (1"-12")
Burst pressure range	0.69-172.3 barg (10-2,500 psig)
Temperature range	-84°C to 538°C (-120°F to 1000°F)
Standard materials	Hastelloy® C, 316 Series Stainless Steel, Nickel, Inconel® 600, Monel®
K <sub>R</sub> Value	K <sub>RGL</sub> : 0.22
Max. Operating Ratio	95%
Performance Tolerance	+/-5%
Manufacturing Range	0%
Fragmentation	Non-fragmenting design
Vacuum Service	Withstands full vacuum (14.7 psi) without separate vacuum support
Fluid compatibility	Gas service and liquid service
Torque requirements	Non torque-sensitive
Cycling or static service	Suitable for high-cycling applications (tested to 1 million cycles)
Relief Valve Isolation	Suitable for safety relief valve isolation
Leak tightness	Helium Leak checked to 1x10 <sup>-8</sup> cc-atm/sec
Design Standards	Designed to meet ASME Section XIII standards

## Certifications

ASME UD

## Related Products

### Sensors

AMS  
SVT

### HOLDERS

LKR  
LKR-P

# Burst Pressure Ranges

LoKr Min/Max Burst Pressure @ 22° C (barg) / 72° F (psig)



SIZE		MATERIAL	MIN barg (psig)	MAX barg (psig)
DN (mm)	(inches)			
25	1	316 Stainless Steel Nickel Inconel Monel Hastelloy C	1.03 (15)	137.9 (2000) 120.66 (1750) 137.9 (2000) 137.9 (2000) 172.3 (2500)
40	1.5	316 Stainless Steel Nickel Inconel Monel Hastelloy C	0.69 (10)	103.42 (1500) 68.95 (1000) 103.42 (1500) 89.63 (1300) 2200 (151.68)
50	2	316 Stainless Steel Nickel Inconel Monel Hastelloy C	0.69 (10)	82.74 (1200) 68.95 (1000) 103.42 (1500) 82.74 (1200) 151.68 (2200)
80	3	316 Stainless Steel Nickel Inconel Monel Hastelloy C	0.69 (10)	82.74 (1200) 68.95 (1000) 103.42 (1500) 82.74 (1200) 137.9 (2000)
100	4	316 Stainless Steel Nickel Inconel Monel Hastelloy C	0.69 (10)	82.74 (1200) 68.95 (1000) 103.42 (1500) 82.74 (1200) 103.42 (1500)
150	6	316 Stainless Steel Nickel Inconel Monel Hastelloy C	0.69 (10)	51.7 (750) 41.37 (600) 51.7 (750) 51.7 (750) 51.7 (750)
200	8	316 Stainless Steel Nickel Inconel Monel Hastelloy C	0.69 (10)	41.37 (600) 34.47 (500) 41.37 (600) 41.37 (600) 51.7 (750)
250	10	316 Stainless Steel Nickel Inconel Monel Hastelloy C	0.69 (10)	27.58 (400) 17.24 (250) 27.58 (400) 27.58 (400) 34.47 (500)
300	12	316 Stainless Steel Nickel Inconel Monel Hastelloy C	0.69 (10)	20.6 (300)



## Free Flow Area / Minimum Net Flow Area (MNFA)

NOMINAL BORE		MNFA	
DN (mm)	inches	mm <sup>2</sup>	Sq. Inch
25	1	554	0.86
40	1.5	1,316	2.04
50	2	2,167	3.36
80	3	4,767	7.39
100	4	8,212	12.73
150	6	18,638	28.89
200	8	32,227	50.02
250	10	50,870	78.85
300	12	72,193	111.9

## Burst Tolerance

+/-5% > 2.8 barg  
+/-5% > 40 psig

+/-0.14 barg ≤ 2.8 barg  
+/-2 psig ≤ 40 psig

## K<sub>R</sub> Value (Frictional Loss Factor)

K <sub>R</sub>	LoKr
K <sub>RGL</sub>	0.22

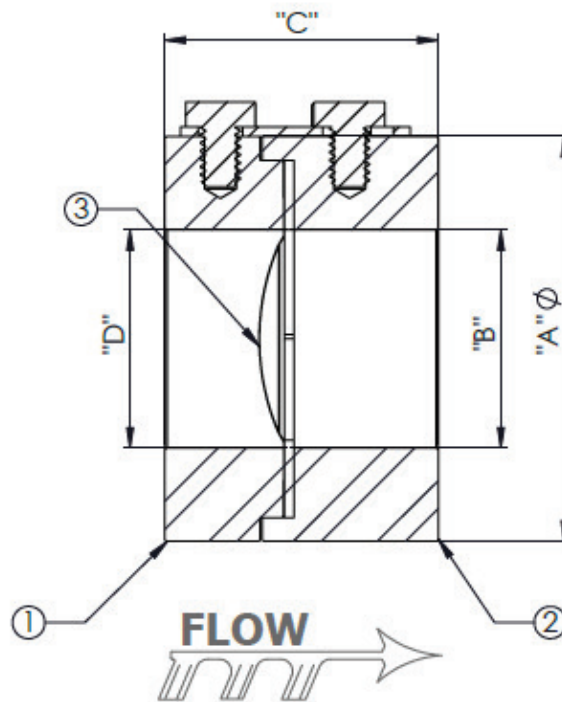

NOMINAL BORE		STANDARD HEIGHT (C)	
DN (mm)	inches	mm	inches
25	1	48.5	1.91
40	1.5	50.8	2.00
50	2	57.1	2.25
80	3	63.5	2.50
100	4	82.55	3.25
150	6	101.6	4.00
200	8	107.9	4.25
250	10	133.3	5.25
300	12	165.1	6.50

FLANGE SPECIFICATIONS	
EN 1092-1 PN DESIGNATED	BS EN 1759-1 ANSI DESIGNATED
PN 6	ANSI 150
PN 10	ANSI 300
PN 16	ANSI 600
PN 20	ANSI 900
PN 25	ANSI 1500
PN 50	ANSI 2500
PN 63	
PN 100	

Standard height dimensions account for the disc and holder assembly only. They do not account for gasket thickness.