

Ubiquisense

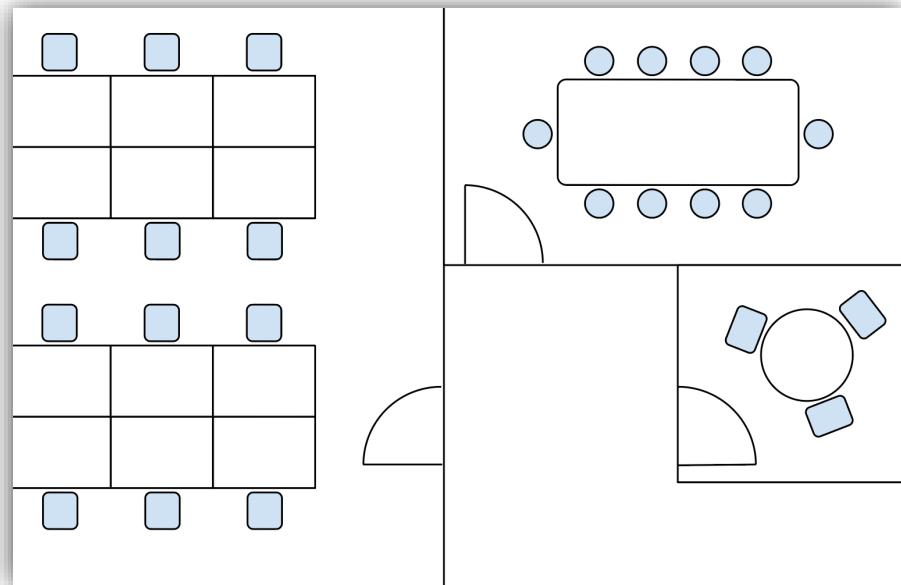

Planning

How to prepare for your installation

Introduction

There are multiple use cases which can be fulfilled with a sensor solution. Before ordering your sensor package you should consider your needs to decide how many sensors you will need.

This document is a guide to understanding what Ubiqisense sensors can do for you, and how to plan your installation.

Ubiqisense Smart Sensor Solution

Ubiqisense smart sensor solutions are made of intelligent sensor devices, gateways and data analytics tools. At the heart of Ubiqisense systems are UBICapture sensors. Connectivity to building automation or access to sensing data through cloud services is enabled by the UBIGateway. For standard installations UBIGateway is created and maintained by Ubiqisense. No user action required.

UBICapture devices observe and extract information about people and objects seen by the device. All devices are equipped with intelligent motion sensing and remote configuration capabilities. By means of an optical sensor and artificial intelligence, captured images are processed by the embedded computer vision algorithm and only meta-data is transmitted from the device. Images are never stored or transmitted by any sensor.

Before you begin

In order to complete your installation plan you will need the following

- Requirements for what information your sensor solution should bring
- Floor plan, including furniture and power outlets

Once you are done with the planning step your outputs will be

- ✓ Floor plan with sensor locations indicated
- ✓ Total number of sensors needed

Standard Features

Occupancy measurement

The default mode for Ubiqisense sensors is occupancy. In occupancy mode the sensor reports the total number of people currently within the monitored area. The area could be part of an open office area with multiple desks, a meeting room, or some other place where people gather.

Normal and Wide Angle sensor

Two sensor models are available, **N** (for Normal) and **W** (for Wide). Which one you choose for each area depends on the space itself and the data you want to gather. The wide angle model is used to cover smaller rooms, its field-of-view offers more versatility. The normal model instead is used to cover bigger rooms or rooms where the exact location of occupants is important, as it has a longer range and higher precision.

Sensor Fusion

In rooms which are too large for a single sensor to cover, sensor fusion can be used to make multiple sensors functions as one. The specifics of this technology are described in detail in the sensor fusion section.

Sensing Area

The following pages provide specific information about the area which can be covered by each of the two sensor types.

Field of view - Normal sensor

The basics parameters for the normal sensor are shown in the table and diagrams below:

Sensor range	10m
Wall mount angle	30°
Horizontal field of view	60°
Vertical field of view	35°
Area covered	~50m ²

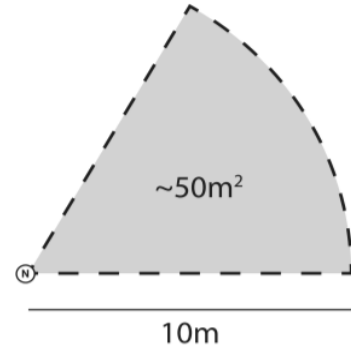

Top view

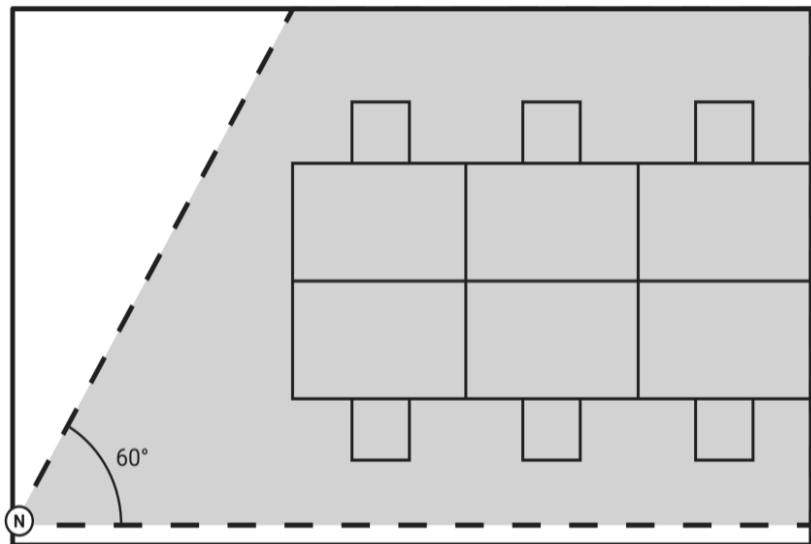

Side view

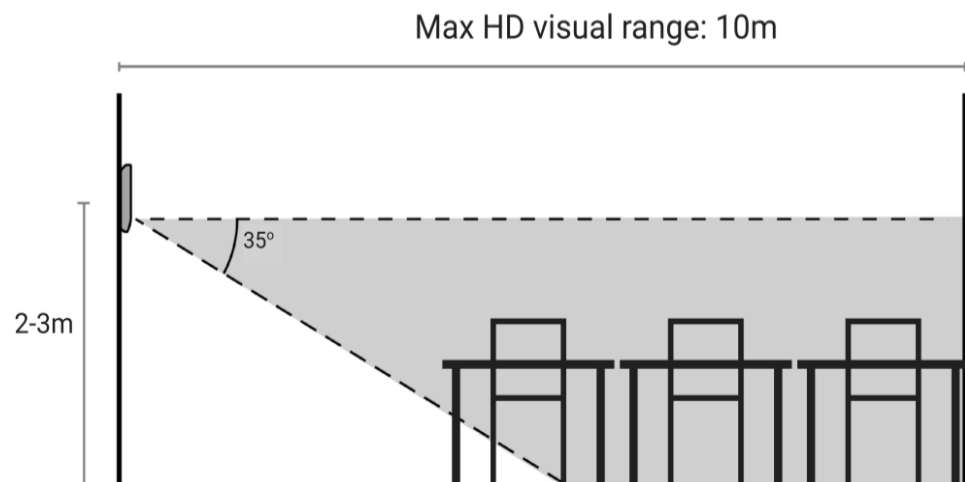

Field of view - Wide angle sensor

The basics parameters for the normal sensor are shown in the table and diagrams below:

Sensor range	7m
Wall mount angle	45°
Horizontal field of view	84°
Vertical field of view	45°
Area covered	~35m ²

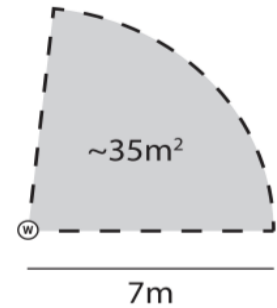

Top view

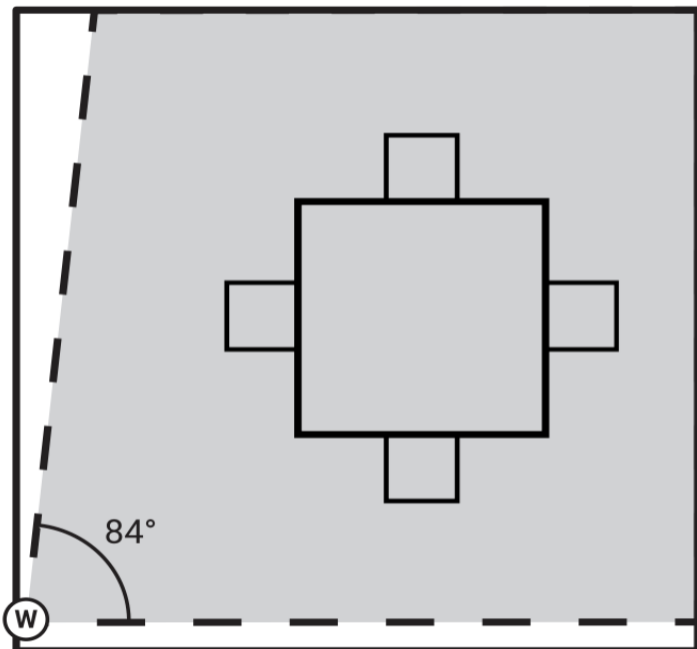

Side view

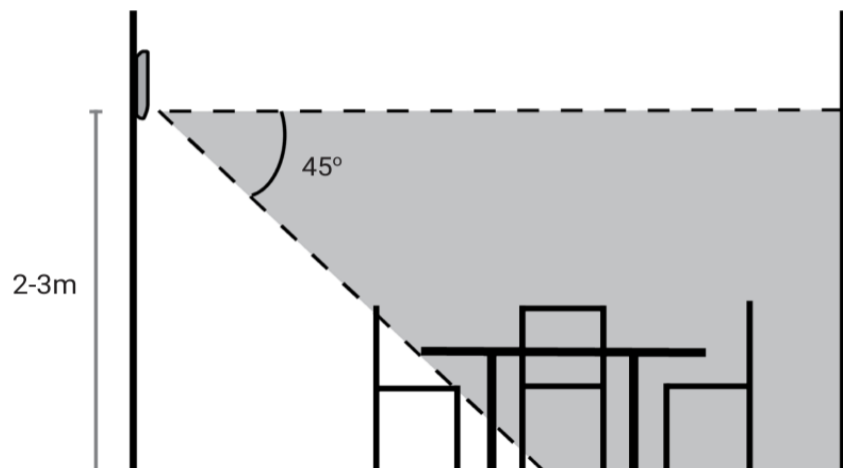

Considerations - How to choose the correct sensor

There are some things to keep in mind when choosing sensor type for your location.

Don't block the field of view

Any objects blocking the view from the sensor will reduce the precision of sensing. Objects could be stationary, like plants, cabinets, lamps, etc. or dynamic, like doors, curtains, movable TV-screens or height-adjustable desks. Make sure that you place sensors where they will always be able to see the area in front of them.

Strong light should be avoided

The optical sensor is sensitive to strong lights. We recommend mounting sensors in places where they will not be subject to direct sunlight or spotlight type lamps.

Blind Zone

Each sensor has a blind zone immediately in front and beneath it. This is illustrated in the diagrams below. For N-type sensors mounted at 210cm above the floor, a regular person sitting closer than 100cm from the sensor will not be detected. For a W-typesensor this value is approximately 70cm.

If the sensor is installed higher up the blind zone will increase in size. For this reason we recommend a mounting height between 2.1m and 2.4m for normal installations.

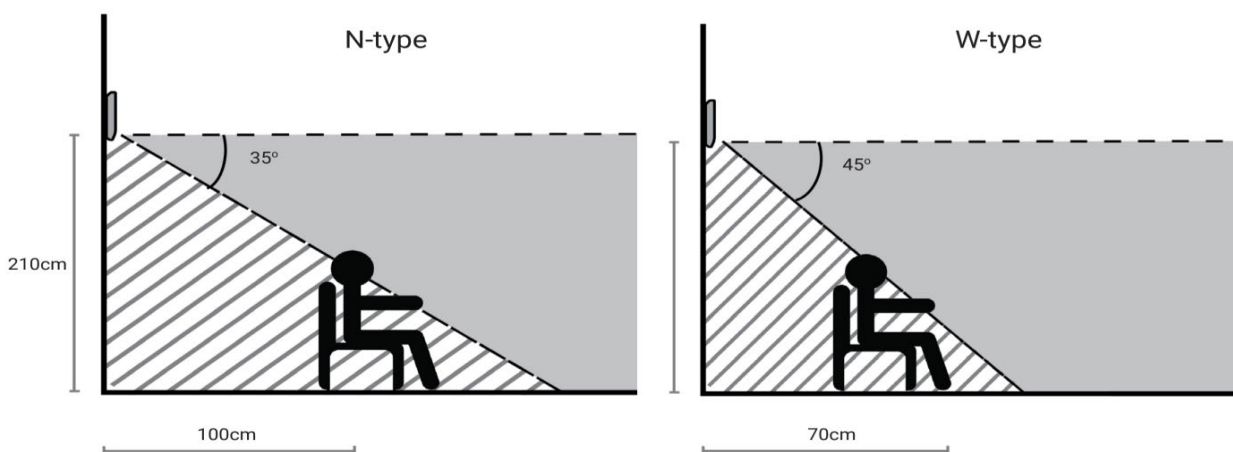

Mounting angle

The mounting brackets provided with each sensor allows for three mounting angles, as illustrated below. If you require different mounting angles you must provide your own mounting brackets.

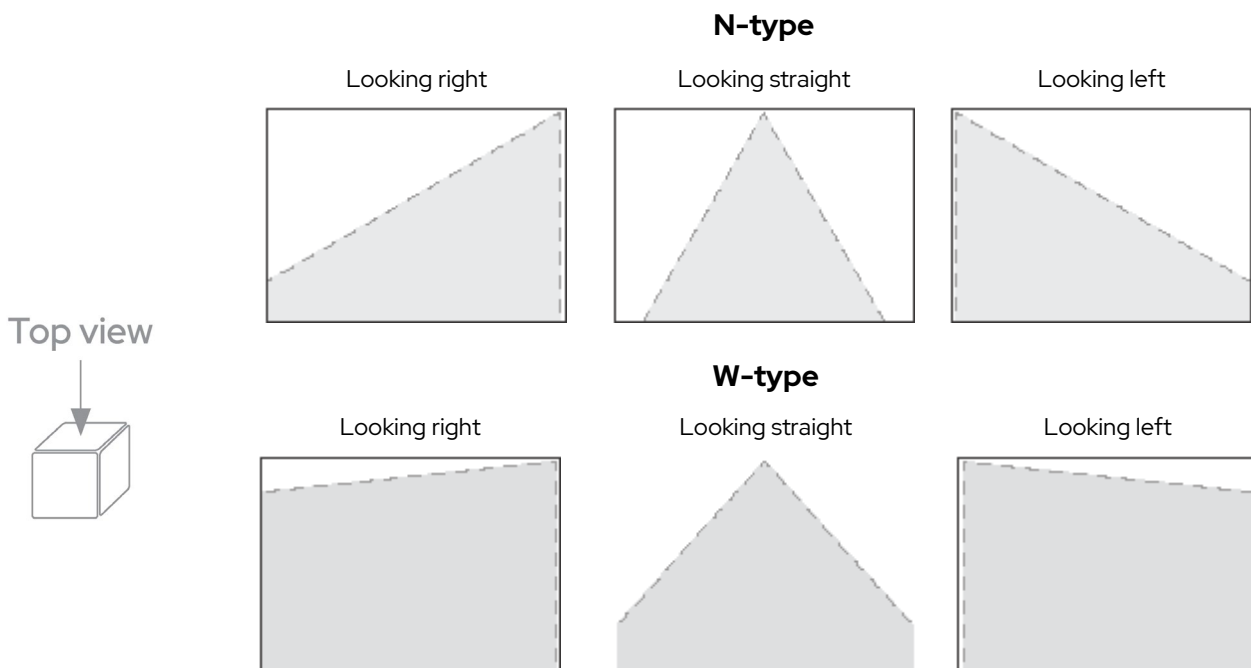

Sensor Fusion - Multiple sensors in single room

For large rooms, or rooms with special geometry, multiple sensors may be needed to cover the entire space. Multiple sensors can be placed in the same room and function as one sensor out of the box, as long as they are monitoring separate areas.

If there is an overlap in their field of view, stereo calibration will be required, which is an advanced feature described under «Advanced Features»

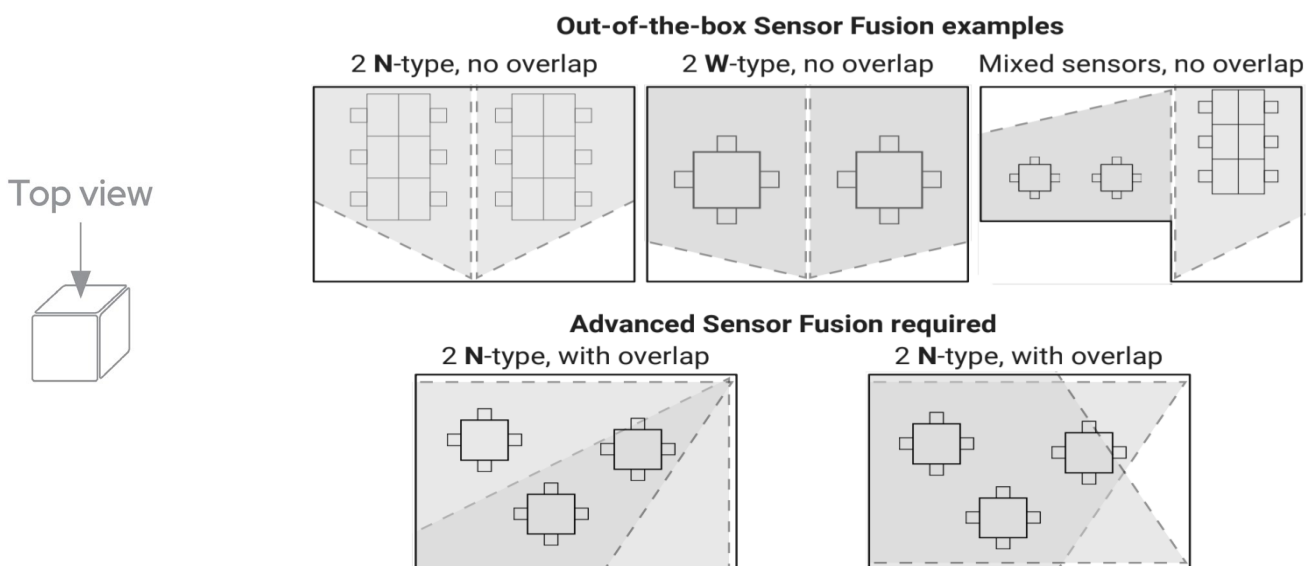

Advanced Features

Footfall Counting

Footfall is an alternative mode for people sensing. Instead of counting the number of people in a room, footfall counts people moving through or across a space such as a doorway or stairwell.

For footfall configuration several additional requirements exist:

- Distance from sensor to crossing point must be 3-5m
- Manual virtual calibration process

For more information and considerations regarding footfall setup contact Ubiqisense.

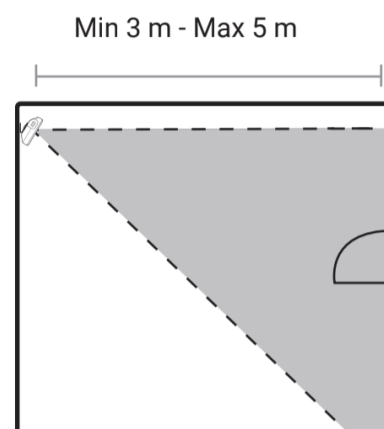

Advanced Sensor Fusion-

Stereo Configuration

To benefit from enhanced accuracy or to avoid occlusion from people sitting close together, there might be the need for two sensors in one room. An example can be seen in the diagram on the right.

For stereo configuration several additional requirements exist:

- Sensor type must be **N**
- Distance between sensors not more than 10m
- Manual calibration process must be performed on site

