

## EMB Datasheet

EMB-4387-2-4 (R1234ze)

EMB-4387-2-7 (R515B)



The EMB Energy Machines™ models are designed for space heating, production of warm tap water, and comfort cooling. They contain either one or two refrigerant circuits with a twin compressor in each.

The EMB models operate with either one or two heat source circuits containing brine. These circuits have an integrated circulation pump and switch between the production of hot tap water and the production of heat.

## Performance

Heating		Cooling	
Heating power	289 kW	Heating power	449 kW
Cooling power	188 kW	Cooling power	364 kW
Electricity compressors total	102.5 kW	Electricity compressors total	173.6 kW
COP	2.84	COP	4.19

## Design parameters

Heating		Cooling	
Heated fluid (in/out)	37 °C / 43 °C	Heated fluid (in/out)	47 °C / 53 °C
Chilled fluid (in/out)	1 °C / -3 °C	Chilled fluid (in/out)	15 °C / 10 °C
Chilled fluid = water, Heated fluid = water			

## Pressure drop at rated flow

Heating		Cooling	
Heated fluid	5 kPa / 12 l/s	Heated fluid	11 kPa / 17.9 l/s
Chilled fluid	12 kPa / 14 l/s	Chilled fluid	25 kPa / 21.5 l/s

## Available pressure at rated flow

Heating		Cooling	
Heated fluid	115 kPa / 12 l/s	Heated fluid	84 kPa / 17.9 l/s
Chilled fluid	102 kPa / 14 l/s	Chilled fluid	56 kPa / 21.5 l/s

## Refrigerant

Options	R1234ze	R515B
GWP value	1.37	288
Charge	14+14 kg	

## Electricity

Rated power supply	400 VAC / 50 Hz / 3-phase
Rated power input	157.3 kW
Rated current	277.4 A
Rated start current	391.7 A
Fuse	315 A

## Dimensions

Length / Width / Height	2950 mm / 1135 mm / 1895 mm
Weight (dry/commissioned)	2300 kg / 2700 kg

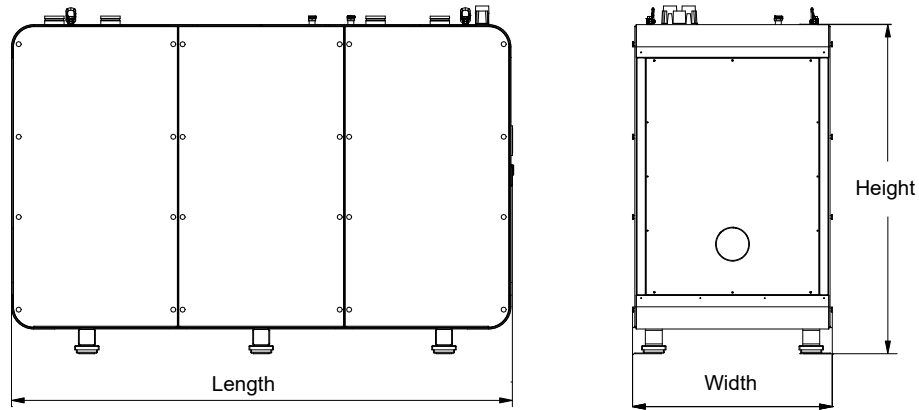

## Ventilated enclosure

Minimum airflow: 55 l/s

Pressure difference shall be  $\geq 20$  Pa

Note: The ventilation fan is not provided with the machine. The pressure difference refers to the difference between the inside and outside of the ventilated enclosure.

## Flow diagram

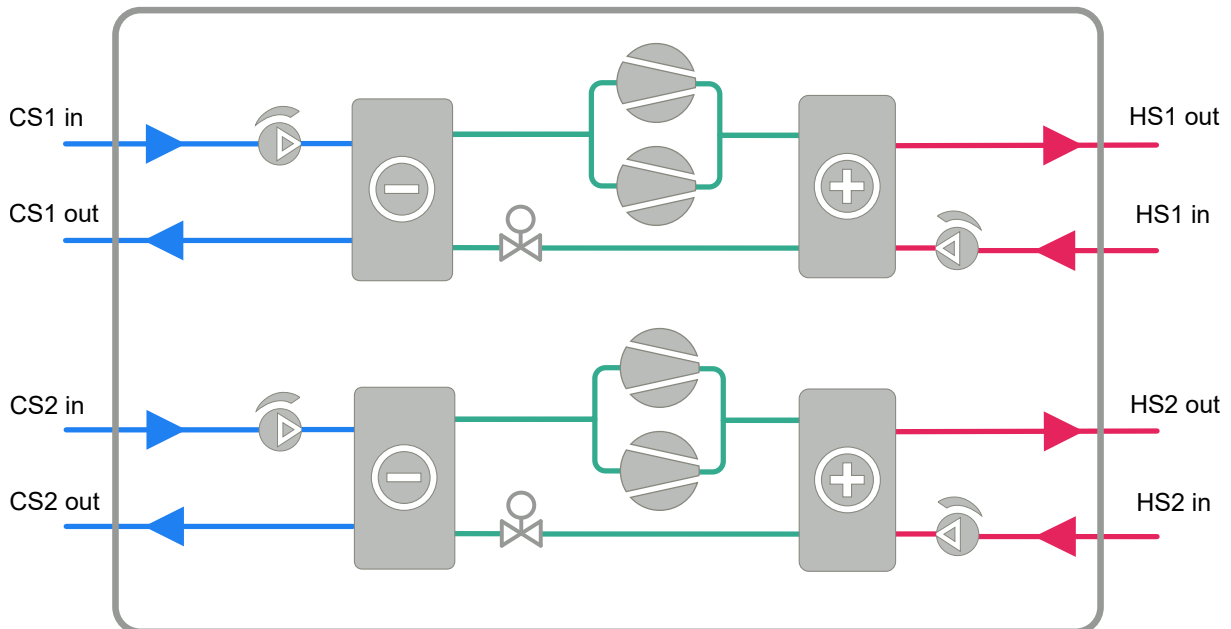

Energy Machines has a policy of continuous product and data improvement and reserves the right to change designs and specifications without notice. While Energy Machines strives for accuracy, we do not guarantee the completeness or correctness of the information.

