

## EMT Datasheet

EMT-1380-1-4-ECO

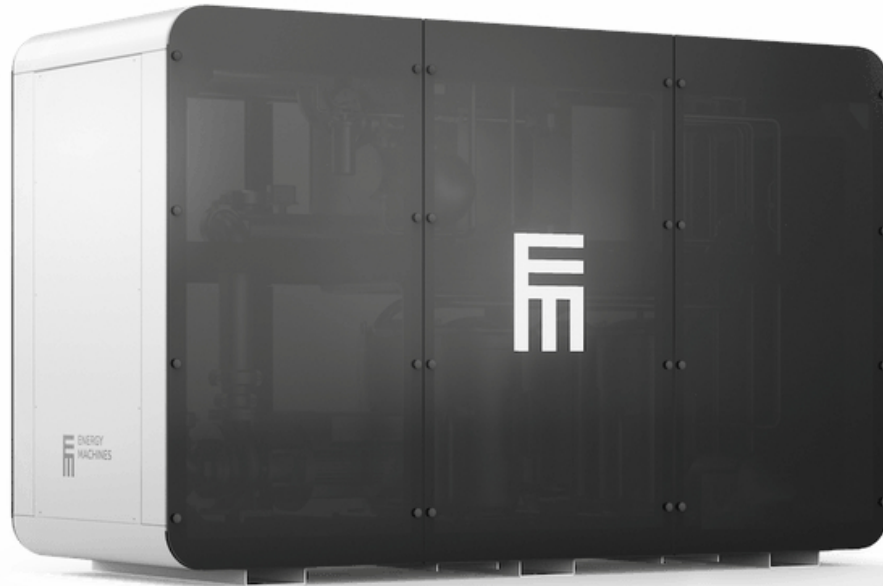

This Energy Machines™ EMT model contains a refrigerant circuit with an oil-free centrifugal turbocompressor. It is classified as a non-positive displacement compressor.

This model is equipped with an economizer heat exchanger, increasing its energy efficiency. The machine's evaporator and condenser are shell-and-tube heat exchangers. The evaporator operates with a flooded evaporation technique.

These components work together to create a powerful and efficient machine.

## Performance

Heating		Cooling	
Heating power	476 kW	Heating power	495 kW
Cooling power	348 kW	Cooling power	388 kW
COP	3.73	COP	3.77

## Design parameters

Heating		Cooling	
Heated fluid (in/out)	57°C / 63°C	Heated fluid (in/out)	37°C / 43°C
Chilled fluid (in/out)	12°C / 7°C	Chilled fluid (in/out)	12°C / 7°C
Chilled fluid: water, Heated fluid: water			

## Pressure drop at rated flow

Heating		Cooling	
Heated fluid	17 kPa / 18.95 l/s	Heated fluid	18.5 kPa / 19.71 l/s
Chilled fluid	27.4 kPa / 16.63 l/s	Chilled fluid	34 kPa / 18.54 l/s

## Rated flow

Heating		Cooling	
Heated fluid	18.95 l/s	Heated fluid	19.71 l/s
Chilled fluid	16.63 l/s	Chilled fluid	18.54 l/s

## Refrigerant

Type	R1234ze
GWP value	1.37
Charge	N/A kg

## Dimensions

Length / Width / Height	2950 mm / 1210 mm / 1945 mm
Weight (dry/commissioned)	2600 kg / 3000 kg

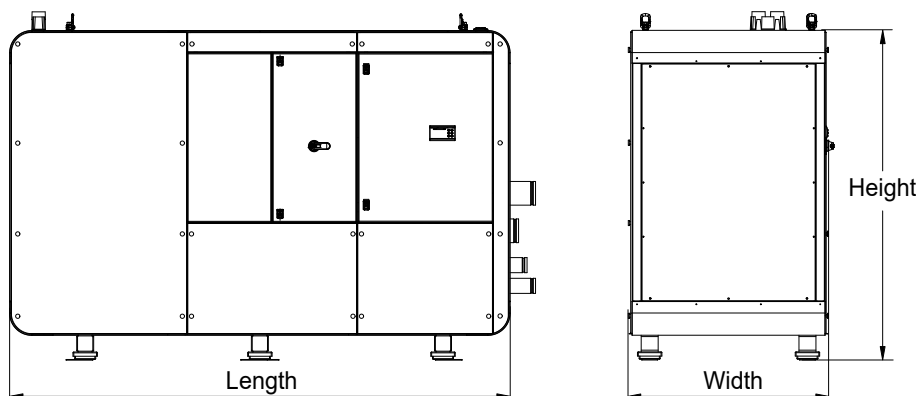

## Electricity

Rated power supply	400 VAC / 50 Hz / 3 phase
Rated power input	130 kW
Rated current	210 A
Fuse	250 A

## Flow diagram

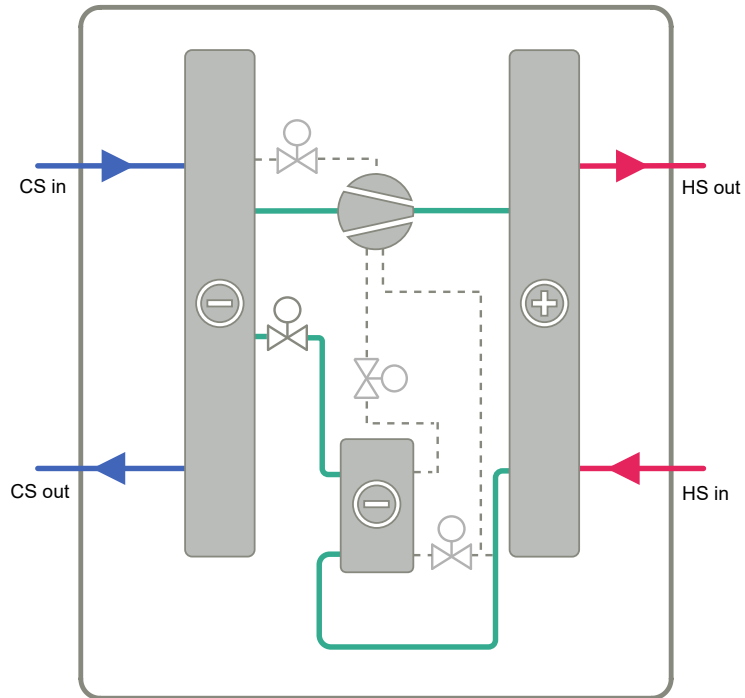

*Energy Machines has a policy of continuous product and data improvement and reserves the right to change design and specifications without notice. While Energy Machines strives for accuracy, we do not guarantee the completeness or correctness of the information.*

