

#76: INCREASING TEMPERATURE RANGE, IMPROVING ADJUSTMENT SENSITIVITY, AND REDUCING THE MINIMUM SPOT SIZE WITH THE APERTURE KIT

For all IRt/c adjustable models an Aperture Kit is provided to offer the ability to extend the target temperature range, improve the adjustment sensitivity of the adjustment potentiometer, and reduce the minimum spot size to as small as 6 mm (1/4").

The kit consists of one 13 mm (1/2") and one 6 mm (1/4") stainless steel apertures and two retaining rings. The apertures and retainers are installed as shown, taking care that the retainers sit and lock between the internal threads. The precise axial location is not critical. Install only one aperture, based on the requirements of your application.

The function of the aperture is to reduce the quantity of radiated energy entering the IRt/c optical system, thus increasing the rated maximum target temperature before burn-out. In addition, since less signal is produced at a given temperature, the adjustment will be less "tweaky" when calibrating the IRt/c installation. The table below lists the range of temperatures for each model recommended with and without the apertures. These recommendations are approximate, since the actual signal level will depend on the actual target characteristics (emissivity, etc.). If there is insufficient adjustment range available with the small aperture

installed, simply replace it with the large one, or remove it. If the adjustment is too sensitive, install an aperture. Use the table below to set up your installation initially, to make sure that the IRt/c is not damaged by excessive radiation, then adjust up or down as required to meet your calibration requirements. The ranges below assume that you are using the technique described in **Tech Note #70** or an equivalent calibration method.

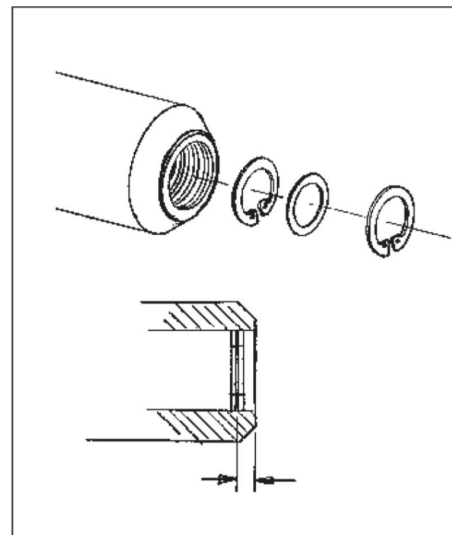

Model	No Aperture	13 mm (1/2") Aperture	6 mm (1/4") Aperture
IRt/c.10A-**-HiE IRt/c.xxxACF-**-HiE IRt/c.xxxAMF-**-HiE	to 370°C (to 700°F)	260 to 820°C (500 to 1500°F)	700 to 1370°C (1300 to 2500°F)
IRt/c.10A-**-LoE IRt/c.xxxACF-**-LoE IRt/c.xxxAMF-**-LoE	to 760°C (to 1400°F)	650 to 980°C (1200 to 1800°F)	870 to 1370°C (1600 to 2500°F)
IRt/c.20A-**-HiE IRt/c.xxxALF-**-HiE	to 650°C (to 1200°F)	540 to 1370°C (1000 to 2500°F)	1260 to 1650°C (2300 to 3000°F)
IRt/c.20A-**-LoE IRt/c.xxxALF-**-LoE	to 980°C (to 1800°F)	540 to 1100°C (1000 to 2500°F)	1370 to 1930°C (2500 to 3500°F)