



**ALL ACCESS
EQUIPMENT**



CMC
THE SPECIALIFT

CMC42F

TECHNICAL DATA SPECSHEET





AERIAL | STANDARD

- 43 ft Working height
- Up to 42'7" lateral reach
- Triple telescopic straight boom
- 90° Independently articulating jib
- 356° non-continuous boom rotation



OUTRIGGERS | STANDARD

- Bubble level
- Inclinometer



CHASSIS | STANDARD

- Live hydraulic boom controls on the chassis and in the basket and outrigger live outrigger functions on the chassis
- Wired remote control for track drive
- Remote connection kit (All Access can connect to machine remotely if unsecured WiFi is shared with machine)
- Automatic leveling



TRACKS | STANDARD

- Black rubber tracks (set)
- Horizontally hydraulically adjustable tracks
- Ability to raise basket & jib up out of the way while driving the tracks



POWER | STANDARD

- Honda iGX390 gasoline engine (replaces the Honda gasoline engine GX390) air-cooled 4-stroke OHV, 11.7 HP @ 3,600 rpm
- 120V Battery charger



PLATFORM | STANDARD

- Removable two man aluminum basket with rounded outer corners for better versatility. Size is 55" long x 27.5" wide x 43.3" high. Optional: single man basket (31.5" L x 23.6" W x 43.3" H) in lieu of the two man basket at no charge.
- High pressure air/water hoses routed internally from the ground to the basket - 2900PSI
- "Dead-man" safety foot-pedal



OTHER | STANDARD

- 1 & 3 years warranty. 1 yr "bumper to bumper" and 3 yrs on certain components. Unlimited use hours.
- Detailed owners maintenance and use manual, including parts and service diagrams
- One (1) Fall arrest safety harness
- Four (4) specially designed sliding outrigger pads





CHASSIS | OPTIONAL

- Wireless remote control
- Travel alarm
- Warning light
- 1 Custom paint color: Choice of more than 200 colors. *No fluorescent or metallic colors*
- 2 Custom paint colors: Choice of more than 200 colors. *No fluorescent or metallic colors*



TRACKS | OPTIONAL

- Non-marking grey tracks (replaces the standard black tracks)
- Track socks



POWER | OPTIONAL

- Yanmar Diesel Engine L100N6CF1T1AA (replaces the Honda gasoline engine iGX390)
- Full lithium battery power (160A 48V) with built in electric charger (replaces Honda gasoline engine)
- Hybrid: Honda gas engine + 160ah lithium batteries
- 12V Battery backup electric pump (intermittently use the 12V battery to operate all functions)
- 120V Auxiliary electric motor w/ battery charger



PLATFORM | OPTIONAL

- 120V Electric outlet in basket with extension cord through the booms
- Basket rotation (+/-90°)
- Removable single man made in USA 24" x 24" fiberglass basket equipped with basket quick connect bracket, replacing the standard basket
- Removable two-man made in USA 24" x 48" fiberglass basket equipped with basket quick connect bracket, replacing the standard basket
- Additional basket: Removable single man aluminum basket 31.5" L x 23.6" W x 43.3" H (this is in addition to the standard two man aluminum basket) basket support with wheels for easy handling is included
- Additional basket: Removable single man fiberglass basket 31.5" L x 23.6" W x 43.3" H (this is in addition to the standard two man aluminum basket) basket support with wheels for easy handling is included.
- Additional basket: Removable two man fiberglass basket 47.2" L x 23.6" W x 43.3" H (this is in addition to the standard two man aluminum basket) basket support with wheels for easy handling is included



OTHER | OPTIONAL

- Biodegradable hydraulic fluid (non-toxic, natural fluid. For extreme cold or sensitive locations)
- Ratchet straps (each. 4 are already included)
- Additional fall arrest aerial lift harness and lanyard kit including storage bag
- Double track drive speed (Honda engine only)
- Automatic Self-Leveling with Radio Remote Control
- Set of 4 cavity outrigger pads



LITHIUM ION BATTERIES



NON-MARKING TRACKS



PLUG-IN ELECTRIC MOTOR

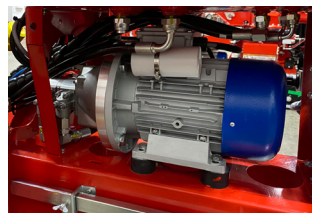

CUSTOM PAINT COLORS





TECHNICAL SPECIFICATIONS

PERFORMANCE

Maximum working height	42' 7"
Maximum side reach at 507 lbs.	21' 10"
Maximum side reach at 176 lbs	27' 10"
Maximum basket capacity with standard basket.	507 lbs
Moveable Jib articulating range	90°
Turret rotation range	+/-356°
Maximum slope to stabilize (deployment)	16° (29%)
Height / Width tracks adjustment	31" - 46"
Maximum slope approach angle / slope	12° - 25° (21% - 46%)
Gradeability -- max. travel angle / slope*	18° (32%)
Maximum crawler travel speed**	0 - 2.2 ft/s

DIMENSIONS

Basket height (basket is removable, variations available)	43"
Basket width	27"
Basket length	48"
Total length (w/ basket rotation)	15' 3"
Length without basket (w/ basket rotation)	12' 10"
Total length (w/o basket rotation)	14' 5"
Length without basket (w/o basket rotation)	12' 2"
Height in transport position	78"
Total width (w/o basket)	31"
Total width (w/o basket, with tracks extended)	47"
Free height from the ground	12"
Tracks (LxW)	50" x 7"
Outrigger spread length	9' 8"
Outrigger spread width	9' 5"
Outrigger foot diameter	7"

WEIGHT

Total weight	3,483 lbs
--------------------	-----------

POWER

Honda iGX390 gas engine	11.6 HP
-------------------------------	---------

**Technical specifications are non-binding, in some cases are approximate, and are subject to change.*

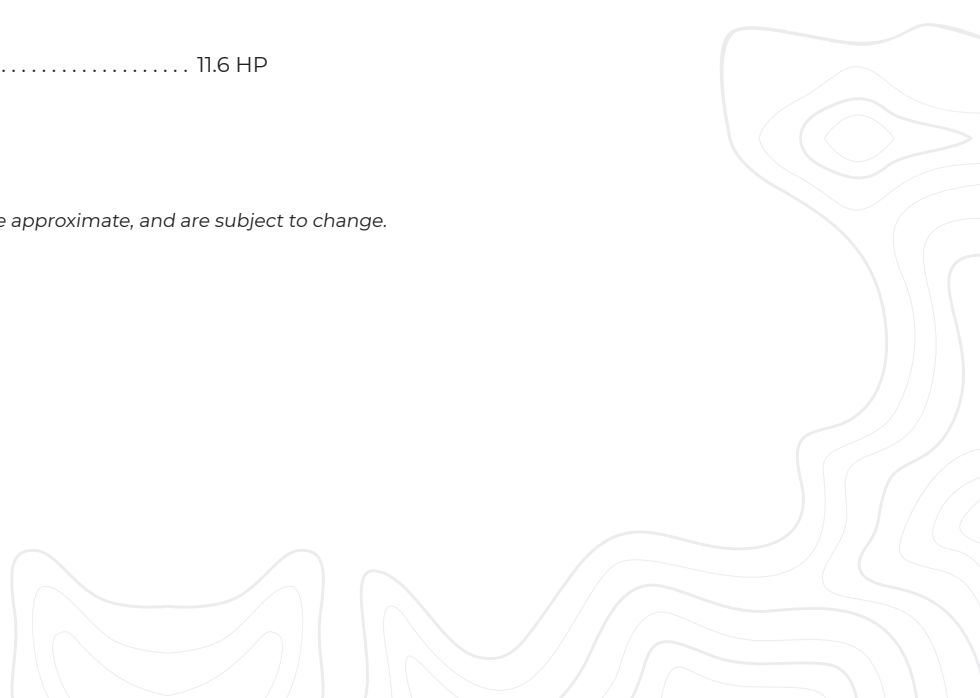

DIAGRAMS

*Measurements are in feet and inches

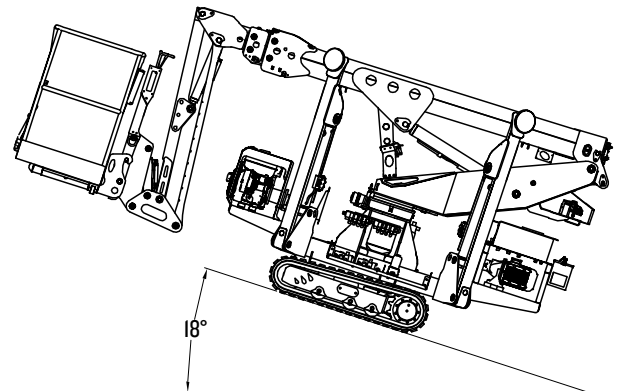
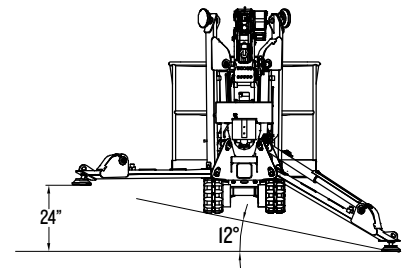
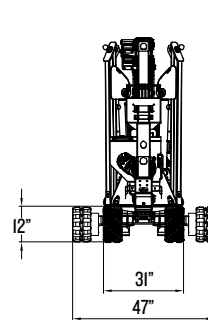
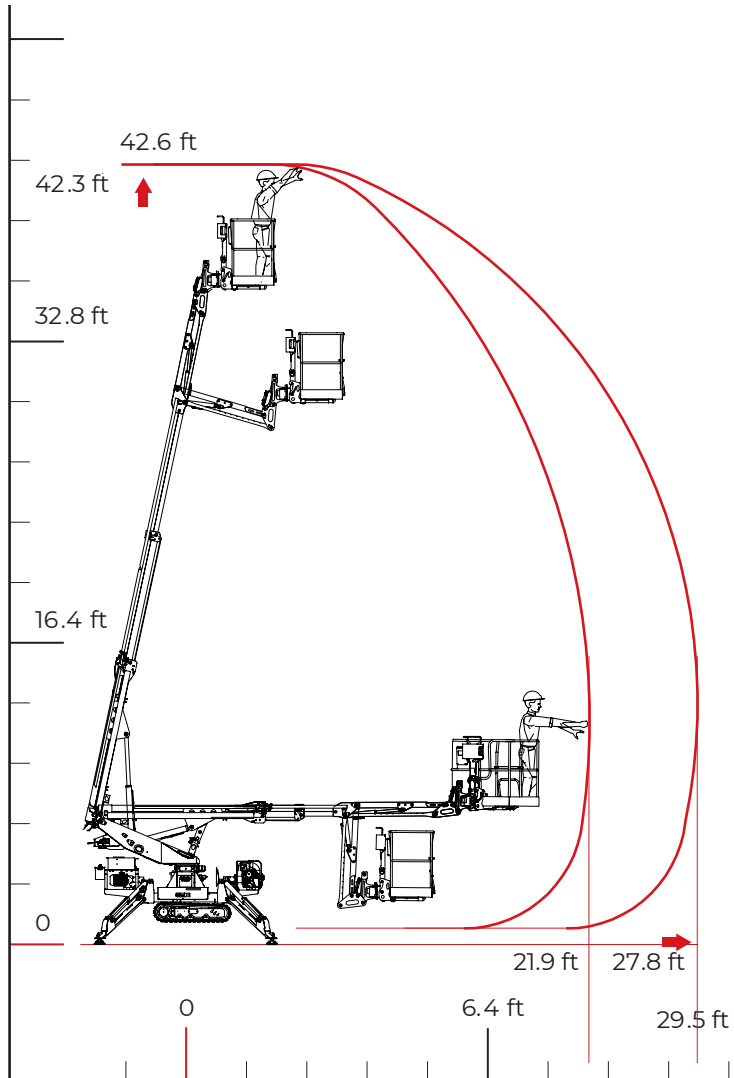
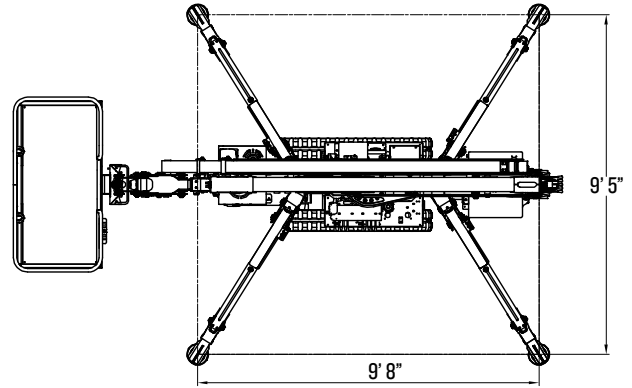
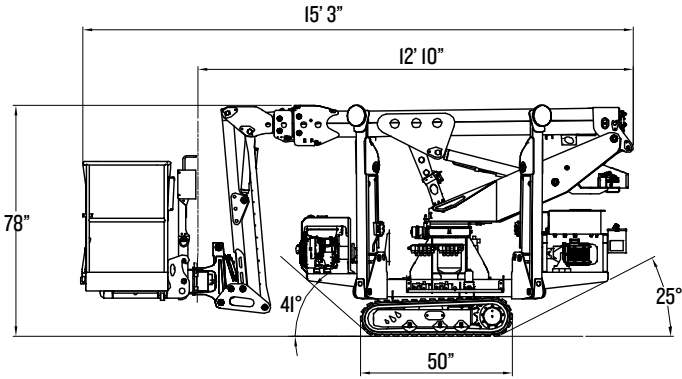

*Technical specifications are non-binding, in some cases are approximate, and are subject to change.



GALLERY

