

For soft and hard wheat test milling



Representative milling

- Includes a breaking part and a reduction part

Reliable

- Repeatable, reproducible and standardized method

Cost effective

- Low maintenance thanks to robust cylinders

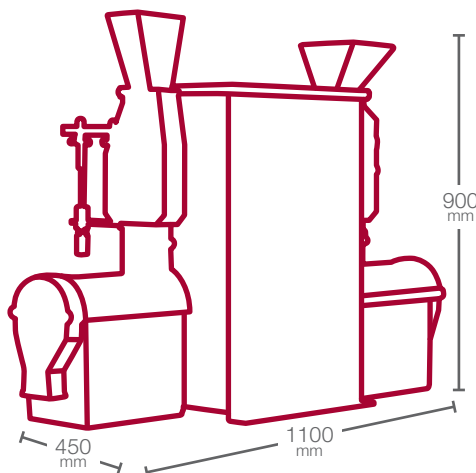

110 Kg

220/380V - 50/60Hz
995W



Test time : **25 minutes**
Operator time : **17 minutes**

Compliant with
NF EN ISO 27971 ; AACC 26-70.01

Operating principle

The CD1 Mill simulates the main steps in an industrial mill :

- 1/Breaking with two streams between three fixed grooved cylinders
- 2/Centrifugal screening
- 3/Reduction by one or two streams between two smooth cylinders
- 4/Centrifugal screening

The main applications

- Selecting wheat
- Evaluating wheat mixes
- Obtaining a representative flour for all your rheological analyses

CD1 operating diagram

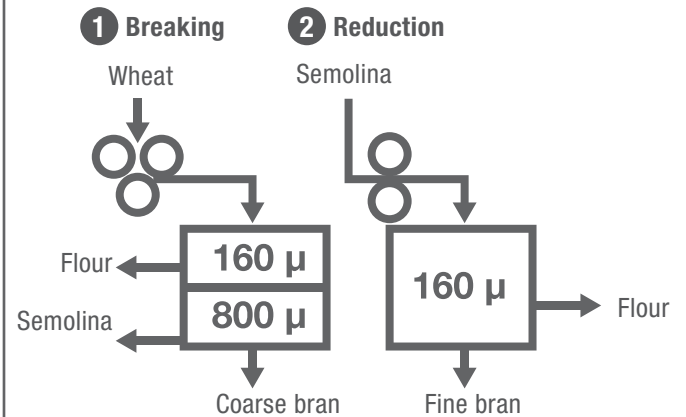

Benefits

Representative

The biochemical composition of the flours processed out of the CD1 is very close to that of industrial flours (purity, granulometry, histological composition, starch damage, quality and quantity of protein).

Reliable

Highly robust cylinders, pre-adjusted fixed graps. Metallic particles are eliminated by magnetic contact before milling.

Simple

Does not require specialized personnel.

