

SW SERIES

Maximum Performance SWISS Turning Centers



THE ULTIMATE MACHINING POWER
GOODWAY®

MAXIMUM PERFORMANCE SWISS TURNING CENTERS

With leading technology and high quality components. GOODWAY SW series Swiss Turning Center provides up to 9-axis control and 4-axis coordinate motion which is highly performed by using high-speed built-in spindle^{*1}, complete tooling system and flexible design of hybrid guide bush. The SW series offers turning, milling, drilling, tapping and other complicated work requirements for micro and precise parts. Due to above advantages, The SW series is excellence for automobile, electronic, clock / watch, medical industry and other related industry.

- ▶ The hybrid guide bush design (bush or bushless are all available), which can be exchanged in short time, this can meet different work requirements.
- ▶ X / Y / Z / XB / ZB axes utilize high speed, high performance linear guide way design which provides rapids up to 30 m/min.

*1 Individual model may vary, please refer to page 5 for more detail information.



APPLICATION



Medical Industry



Clock / Watch Industry



Automobile



Electronic Industry

FLEXIBLE TOOLING SYSTEM

Complete tooling system design can satisfy with front, rear and side different processing requirements.



Tooling System		SW-20 / 32	SW-42
A	O.D. tool	6	5 6
B	Front-end	I.D. tool	4 5 5
	Rear-end		4 5 5
C	Cross	Live tool*1	5 (max.) 4 5
	Front-end / Rear-end		5 (max.) 5 5
Backworking Tooling System			
D	Rear-end	I.D. tool	4 (total)
		Live tool	

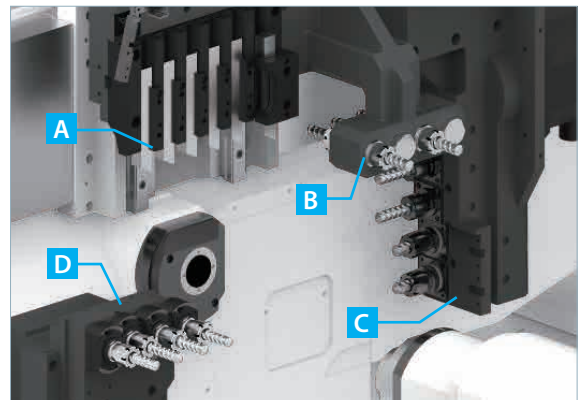

*1 The upper 3 positions are a fixed unit for cross milling and drilling, the bottom 2 positions can be increased up to front-end X5 and rear-end X2 live tools.

Front-end / Rear-end live tools **C** (for SW-20 / SW-32 only)

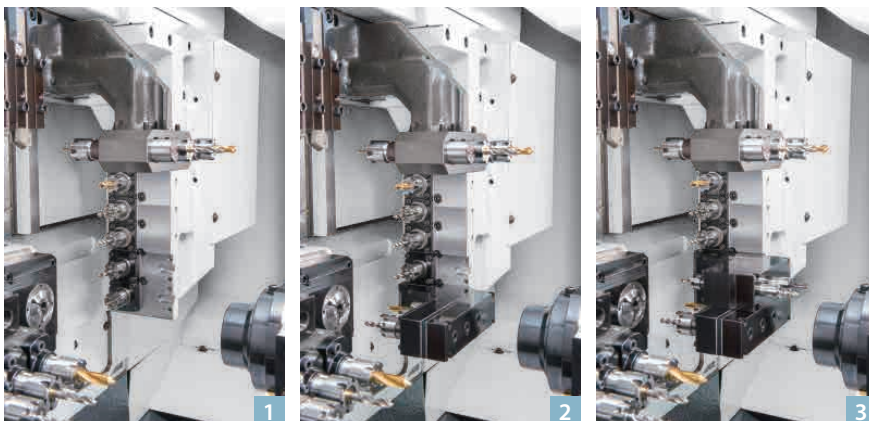

- 1 Standard**
Cross live tool X 5
- 2 Expansion**
Cross live tool X 4
Front-end live tool X 3
- 3 Expansion**
Cross live tool X 3
Front-end live tool X 5
Rear-end live tool X 2

MACHINING VARIATIONS

Flexible multi-task supported and abundant standard and optional functions provided the SW series powerful processing ability.



SW series video online

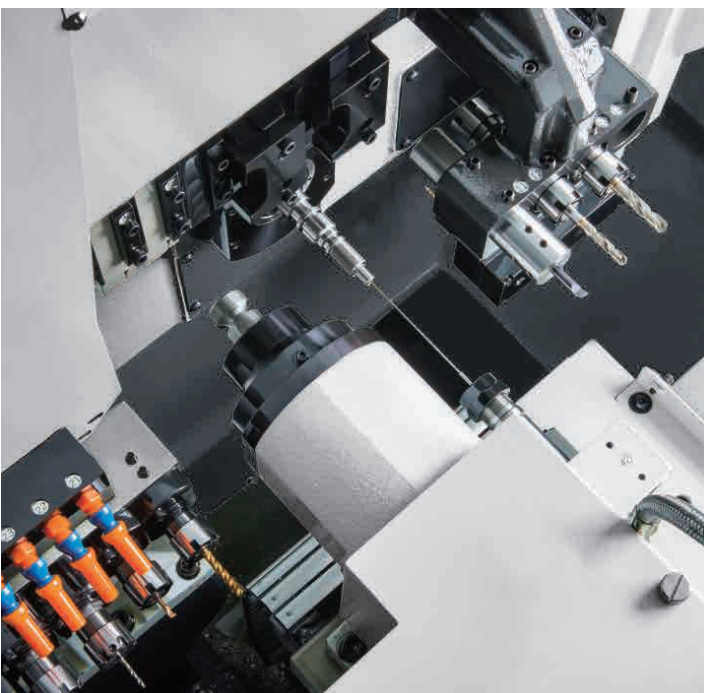
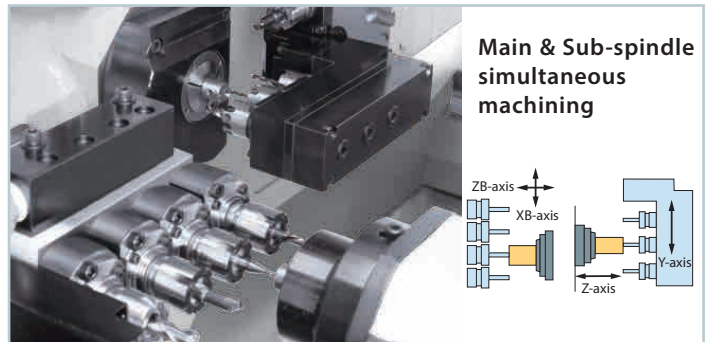
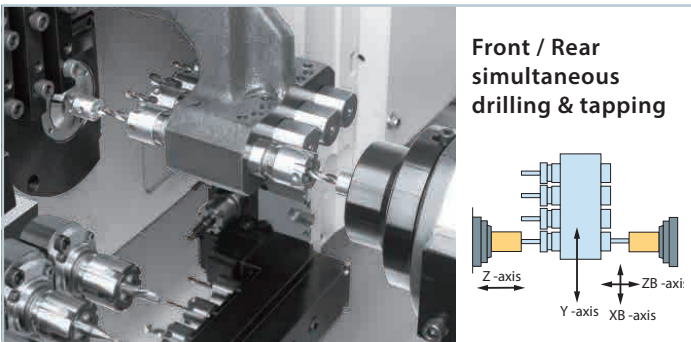
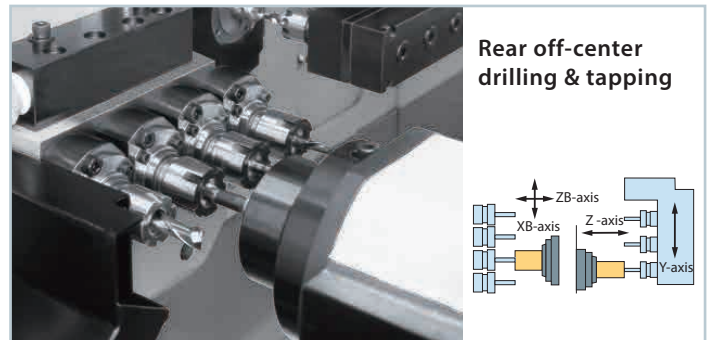
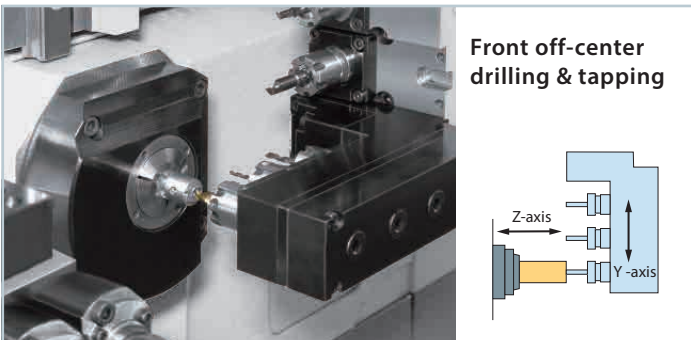
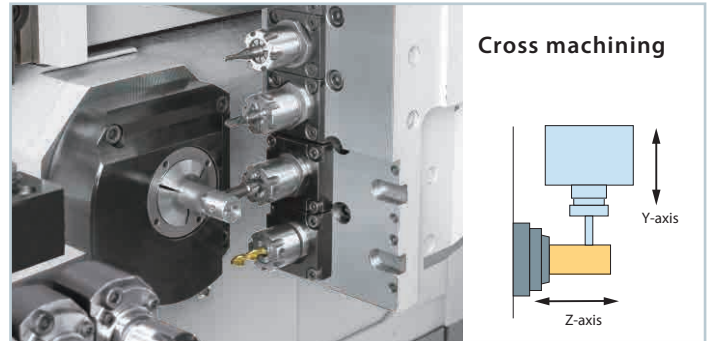

Deep hole drilling (for SW-32 only)

- Sub-spindle applied 2 U-Drill devices which can offer deep hole drilling requirement but additional tool position is no needed.
- With high pressure coolant system, it can ensure the best deep hole drill performance.

- Tool diameter : $\varnothing 1.32$ mm
- Tool length : 150 mm
- High-pressure coolant system : 140 Bar
- Material : SUS303



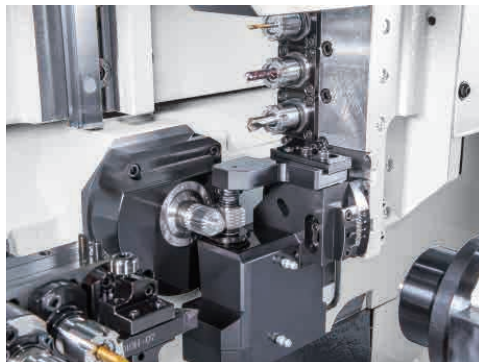

Hobbing

option

Gear hobbing tools holder is particularly much higher strength, smaller volume and more convenient for changing. It provides larger machining range of gear hobbing with excellent machining accuracy on surface.

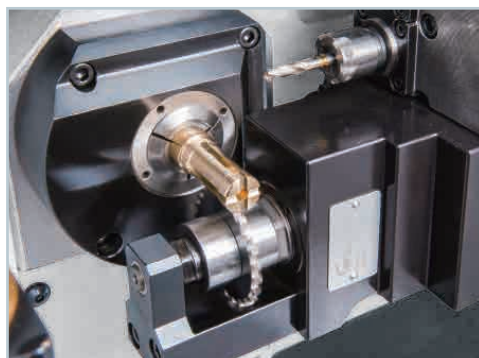
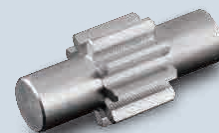

Slotting

option

Using slotting driven tools to provide high efficiency and extend tool life compare to normal end milling tools.



Thread whirling

option

By using multiple cutters of thread whirling tools and technology of pneumatic coolant to remove the chips to achieve the demand of machining high speed and high accuracy of thread.



Polygon turning

option

By using the speed ratio of spindle and driven tool holders to provide rapid polygon turning ability.

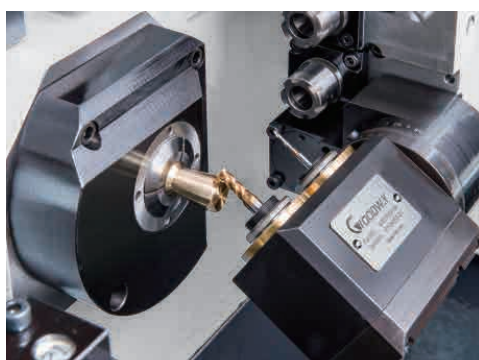

Angle head driven tools

option

High rigidity, easily angle adjustment for bevel machining. Adjust range (-90° ~ $+90^{\circ}$). Every 5 degree divided positioning.



ADVANCED SPINDLE TECHNOLOGY



The built-in spindle design reduces centrifugal force effect and restrains spindle vibration, which increases the spindle life span and improves long-term machining accuracy.

The clamping mechanism uses rotary hydraulic cylinder which can firmly clamp the workpiece and provides fast response, flexible clamping force .

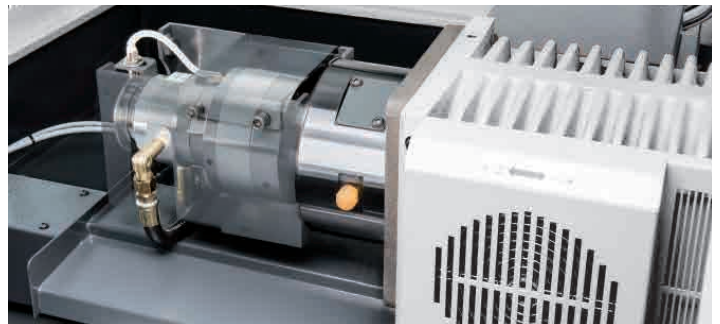

	Spindle motor		Clamping mechanism	
	Built-in	Outboard	Hydraulic cylinder	Clutch
SW-20	H1	H2	H1	H1 / H2
SW-32	H1 / H2	-	H1 / H2	H2
SW-42	-	H1 / H2	H1	H2

H1 : Main spindle H2 : Sub-spindle

Hybrid guide bush

Special interface mechanical design of guide bush can be mounting or dismount base on actual situation. It is more flexible in use and save cost on facility and space in the factory.

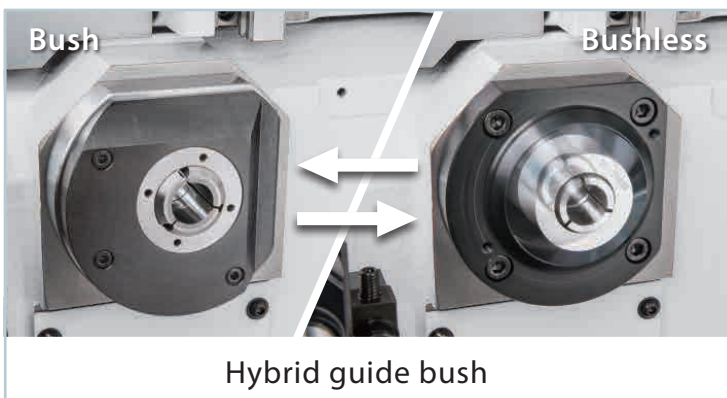

Bush

Suitable for long bar work-piece

Bushless

Suitable for cold working bar or high price raw material

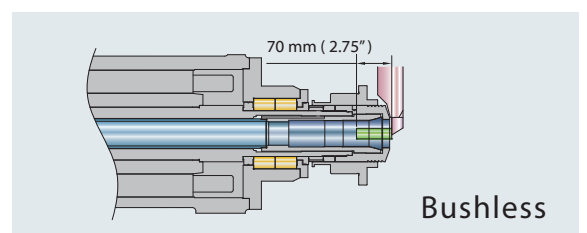
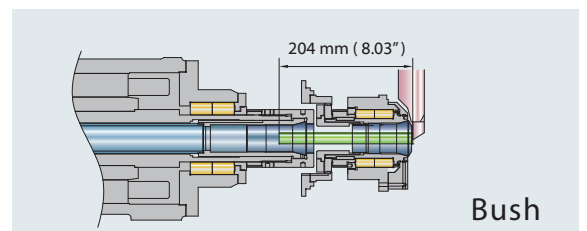

▶ Remaining bar length (SW-32)

REAR-END & C-AXIS MACHINING CAPABILITY

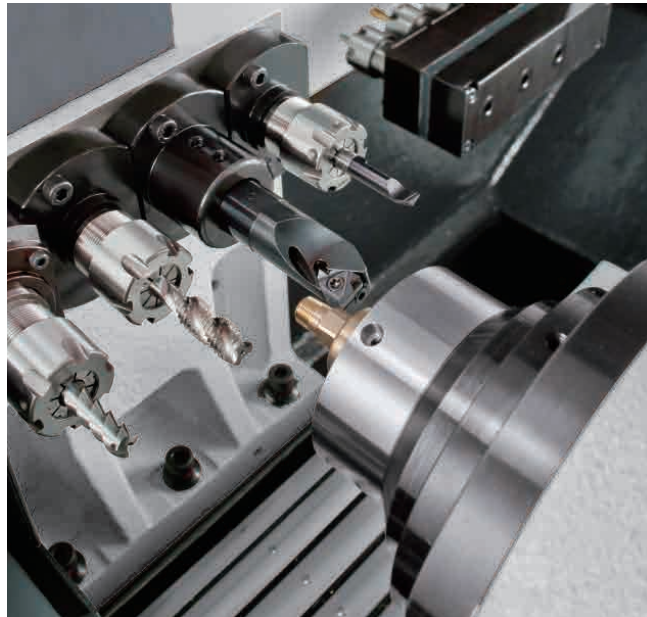

Sub-spindle

High precision built-in*1 sub-spindle design and movement of the sub-spindle is applied with high speed linear guide way which provides rapids up to 30 m/min.

*1 Individual models may vary, detail specification please see page 5.



C-axis

Working with the live tooling and 0.001° high resolution C-axis enables the machine to perform multiple tasks, such as drilling, tapping, and milling operations, including cylindrical and polar coordinate interpolations.

Spindle output

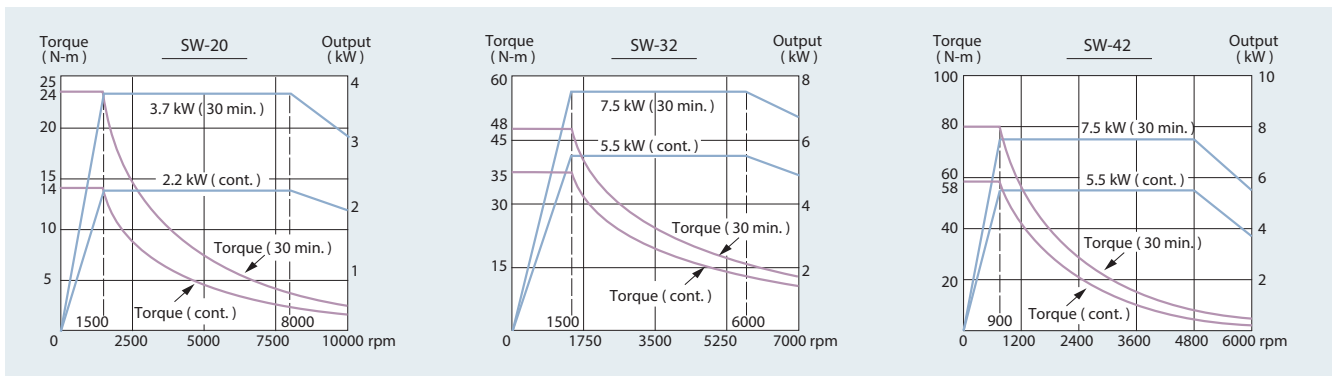

Sub-spindle output

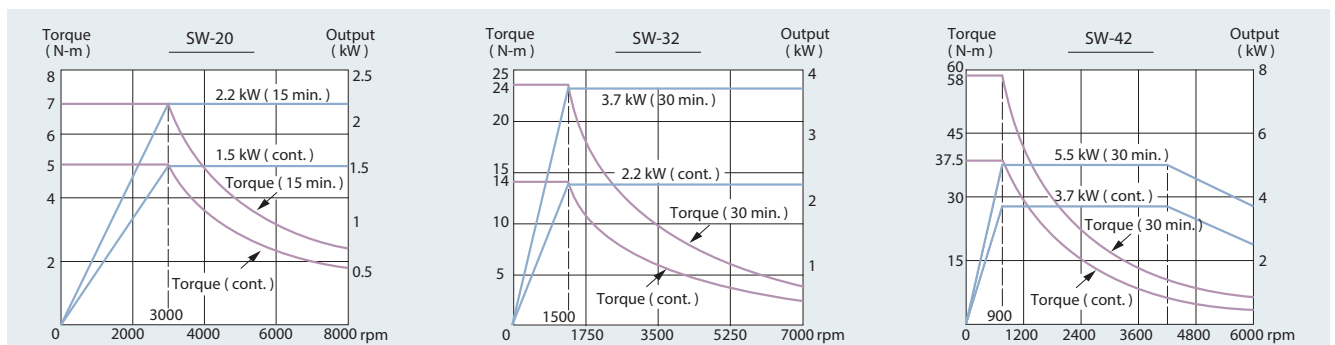

STANDARD & OPTIONAL FEATURES

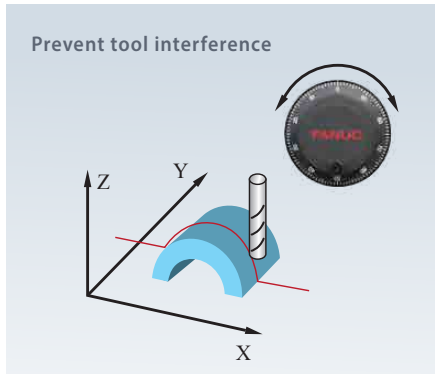

Manual handle retrace

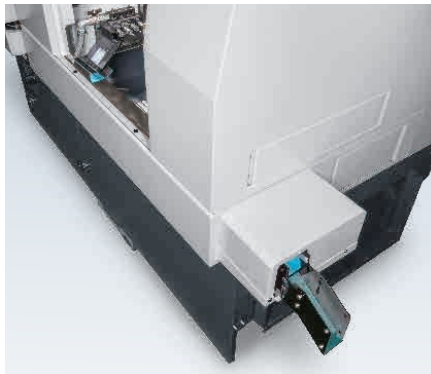

Transport conveyor



Long parts ejector

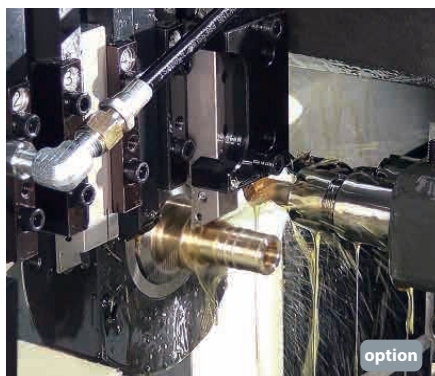

Coolant through tool



A/C cooling system

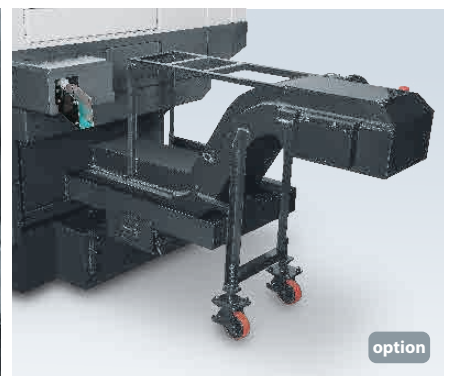

Chip conveyor



Coolant through sub-spindle



Bar feeder

ALLCOOL SYSTEMS

- ▶ Compact machine size.
- ▶ Filter for open loop.
- ▶ Use disposable filter bag.
- ▶ Built-in the pressure is too low or too high alarm.

Models	SK1000	SC1500	SC2000
Max. pressure	70 bar (kg/cm ²) 1,000 PSI	100 bar (kg/cm ²) 1,500 PSI	140 bar (kg/cm ²) 2,000 PSI
Max. flow rate	12 LPM (3 GPM)	25 LPM (6.5 GPM)	19 LPM (5 GPM)
Max. load	3 HP (2.2 kW)	7.5 HP (5.5 kW)	7.5 HP (5.5 kW)



High-pressure coolant system

S : Standard O : Option
 - : Not Available C : Contact Goodway

		SW-20	SW-32	SW-42
SPINDLE				
Main spindle motor configuration		S	S	S
Rigid tapping		S	S	S
C-axis		S	S	S
Spindle brake		S	S	S
WORK HOLDING				
Spindle hardness collect		O	O	O
Spindle tungsten collect		O	O	O
Sub-spindle hardness collect		O	O	O
Sub-spindle tungsten collect		O	O	O
Special work holding chuck		O	O	O
GUIDE BUSH				
Stationary guide bush		O	O	O
Revolving guide bush		S	S	O
Rotary magic guide bush		O	O	O
Tungsten guide bush		O	O	O
COOLANT				
Coolant pump		S	S	S
High-pressure coolant system	5.0 MPA	O	O	O
	7.0 MPA	O	O	O
	10 MPA	O	O	O
	14 MPA	O	O	O
Roll-out coolant tank		S	S	S
Coolant flow switch		S	S	S
Coolant level switch		S	S	S
CHIP DISPOSAL				
Chip conveyor		O	O	O
Chip cart with coolant drain		O	O	O
Oil mist collector		O	O	O
LIVE TOOLING				
ER16 cross live tool		O	O	-
ER16 3-spindle front-end live tool		O	O	-
ER16 2-spindle front-end live tool		O	O	-
ER16 slotting holder		O	O	-
ER16 3-spindle angle head driven tools (0 ~ 360°)		O	O	-
ER16 rear-end live tool		O	O	-
ER20 cross live tool		-	O	O
ER20 3-spindle front-end live tool		-	O	O
ER20 2-spindle front-end live tool		-	O	O
ER20 slotting holder		-	O	O
ER20 3-spindle angle head driven tools (0 ~ 360°)		-	O	O
ER20 rear-end live tool		-	O	O
Thread whirling holder		O	O	O
Polygon turning holder		O	O	O
AUTOMATIC OPERATION SUPPORT				
Bar feeder		O	O	O
Bar feeder interface		S	S	S
Parts catcher		S	S	S
Work-piece transport conveyor		S	S	S
Long parts ejector		O	O	O
SAFETY				
Fully enclosed guarding		S	S	S
Door interlock (incl. Mechanical lock)		S	S	S
Impact resistant viewing window		S	S	S
Low hydraulic pressure detection switch		S	S	S
Over travel (soft limit)		S	S	S
Load monitoring function		S	S	S
Cut-off detector		S	S	S
OTHERS				
Electrical cabinet	A/C cooling system	O	O	O
	Heat exchanger	S	S	S
Hydraulic system		S	S	S
Pneumatic system		S	S	S
Advanced auto lubrication system		S	S	S

		O _i -TF	31 _i
FANUC CONTROL FUNCTIONS			
Display	8.4" color LCD	O	O
	10.4" color LCD	S	S
Graphic function	Standard	S	S
	Dynamic	O	O
Part program storage size O _i -TF : each path 31 _i : total	512 K bytes	S	-
	1 M bytes	O	S
	2 M bytes	-	O
	4 M bytes	-	O
	8 M bytes	-	O
Registerable programs O _i -TF : each path 31 _i : total	400	S	-
	500	O	-
	1,000	-	S
	4,000	-	O
Tool offset pairs O _i -TF : each path 31 _i : total	99	-	S
	128	S	-
	200	O	O
	400	-	O
	499	-	O
Servo HRV control	HRV 3	S	S
	Automatic data backup	-	S
	Synchronous / Composite control	S	S
	Superimposed Control	S	S
	Inch / metric conversion	S	S
Polar coordinate interpolation	S	S	
Cylindrical interpolation	S	S	
Multiple repetitive cycle	S	S	
Rigid tapping	S	S	
Unexpected disturbance torque detection function	S	S	
Spindle orientation	S	S	
Constant surface speed control	S	S	
Spindle speed fluctuation detection	S	S	
Embedded macro	S	S	
Spindle synchronous control	S	S	
Background editing	S	S	
Tool radius / Tool nose radius compensation	S	S	
Multi-language display	S	S	
Cs contour control	S	S	
Polygon turning	S	S	
Helical interpolation	S	S	
Direct drawing dimension programming	S	S	
Thread cutting retract	S	S	
Variable lead threading	S	S	
Multiple repetitive cycle II	S	S	
Canned cycles for drilling	S	S	
Synchronous / Composite / Superimposed control by program command	S	S	
Tool nose radius compensation	S	S	
Chamfering / Corner R	S	S	
AI contour control I	O	S	
Multi part program editing	S	S	
Manual handle retrace	S	S	
Manual intervention and return	S	S	
External data input	S	S	
Addition of custom macro	S	S	
Increment system C	S	S	
Run hour & parts counter	S	S	
Auto power-off function	S	S	
RS-232 port	S	S	
Memory card input / output (CF + USB)	S	S	
Ethernet	S	S	

DIMENSIONS

SW-20

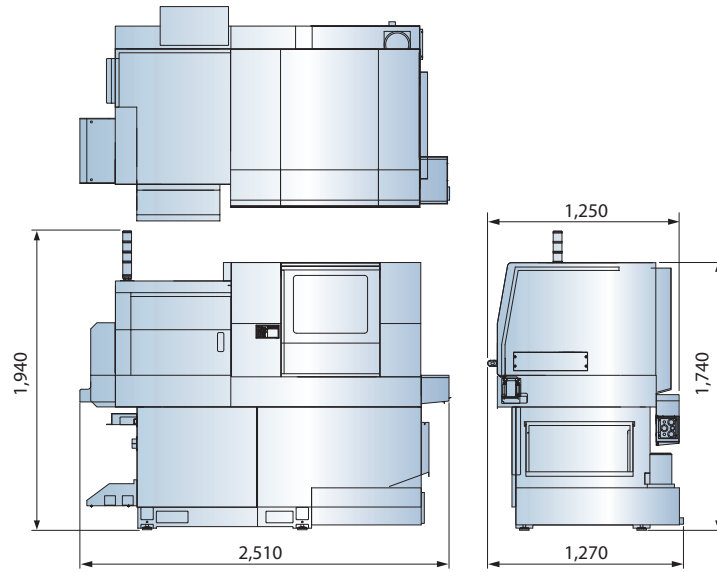

SW-32

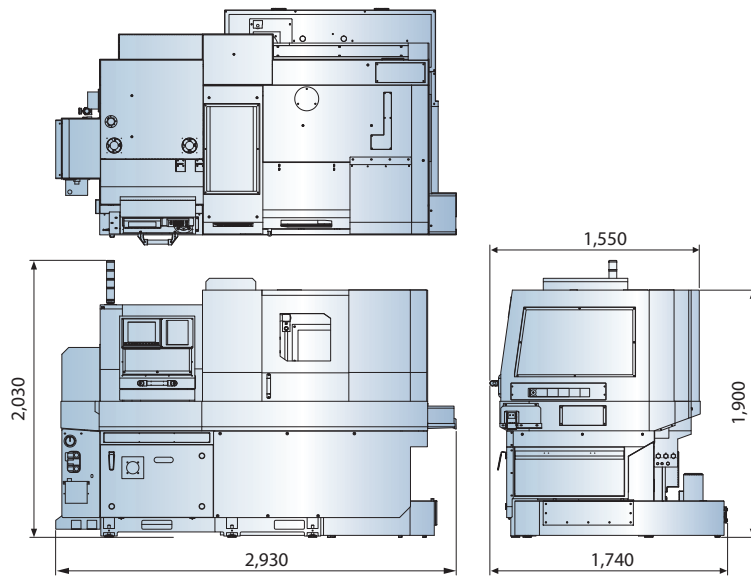

SW-42

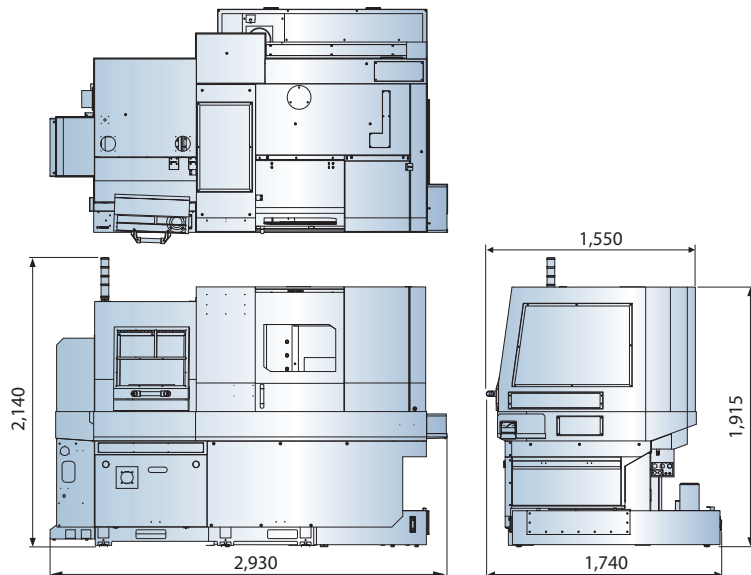

SW-20

Bush

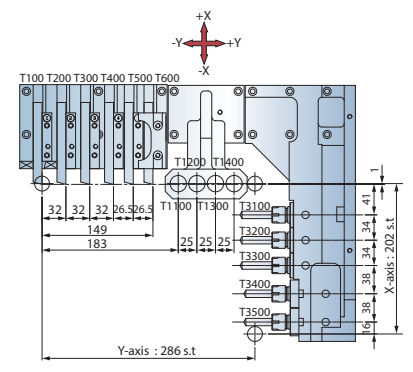
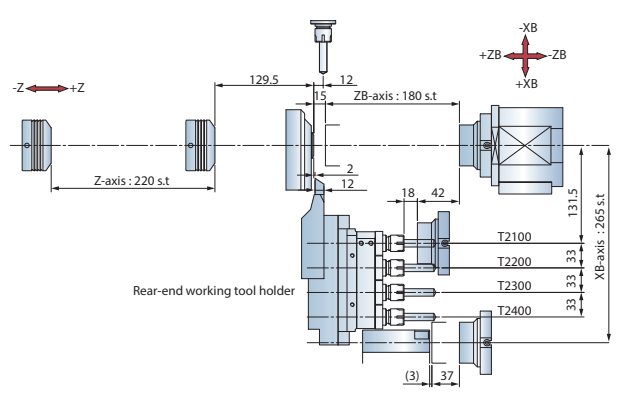

Bushless

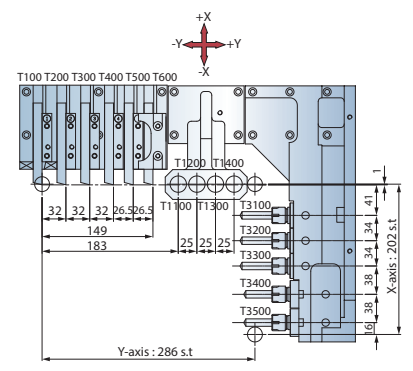
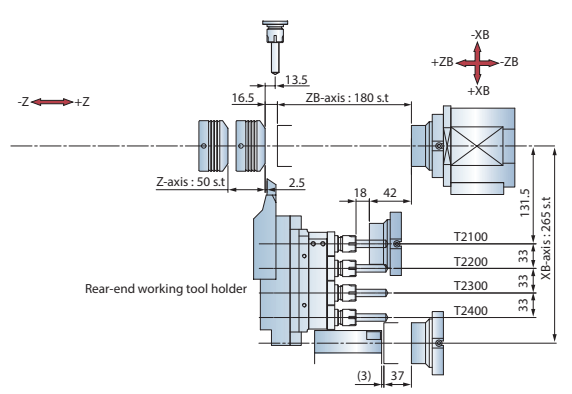

SW-32

Bush

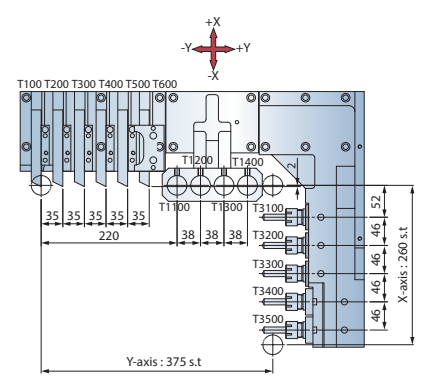
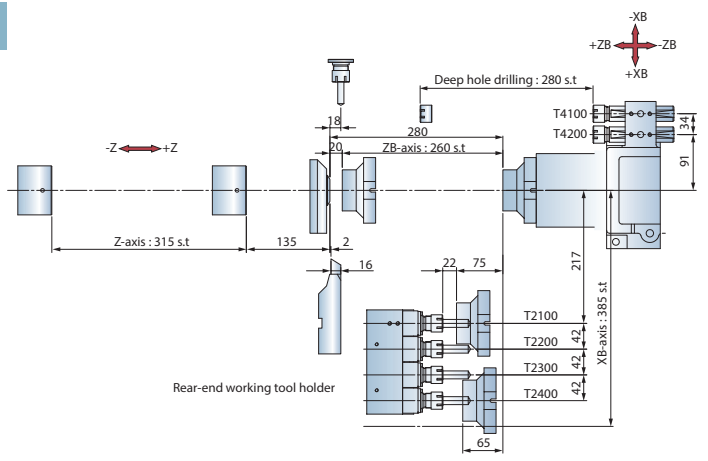

Bushless

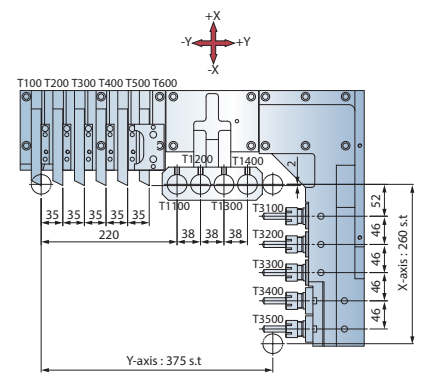
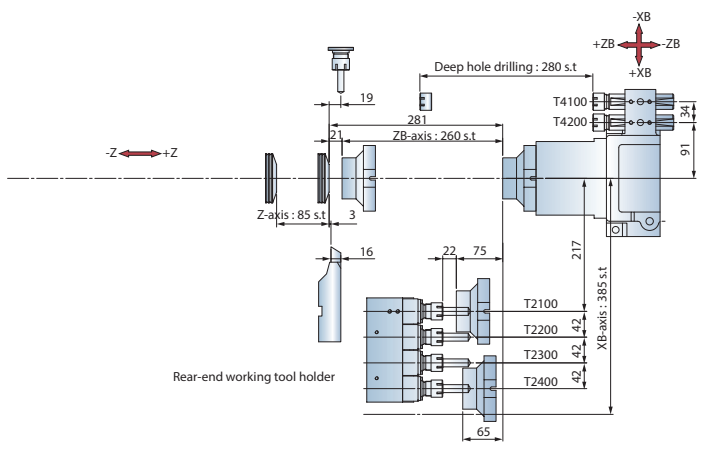

SW-42

Bush

O.D. tools X 5
live tools X 4

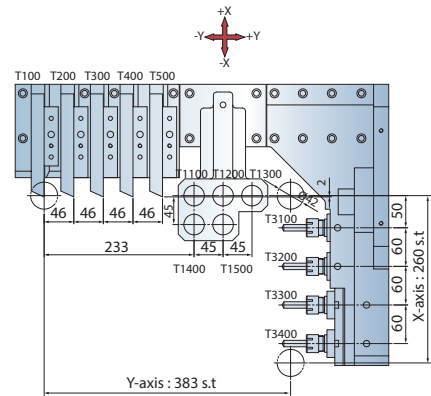
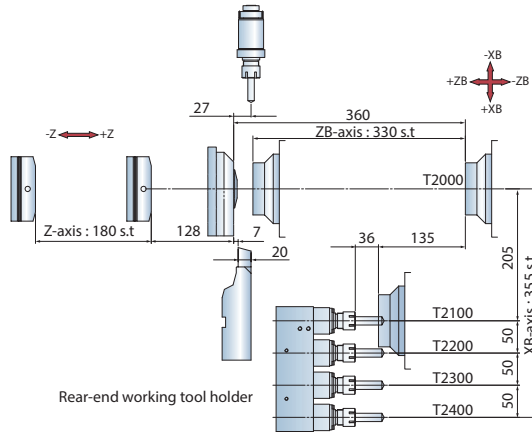

Bushless

O.D. tools X 5
live tools X 4

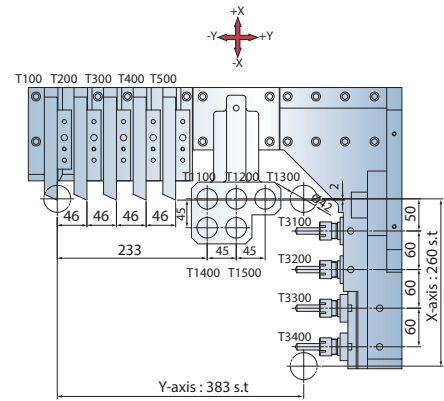
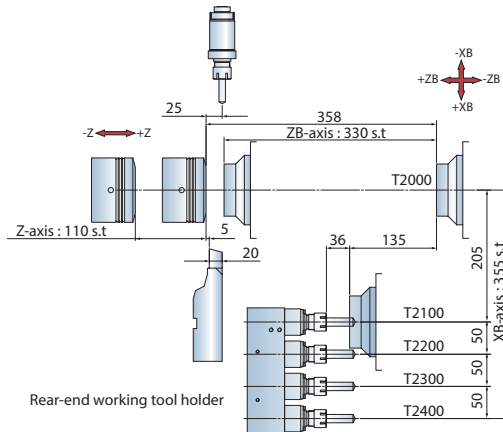

Bush

O.D. tools X 5
live tools X 5

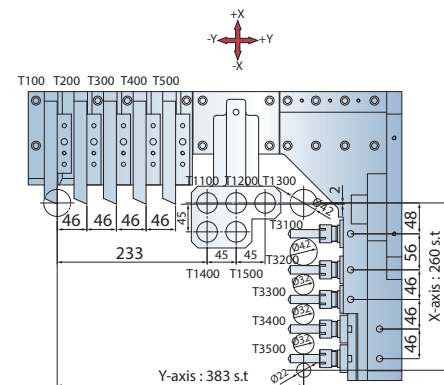
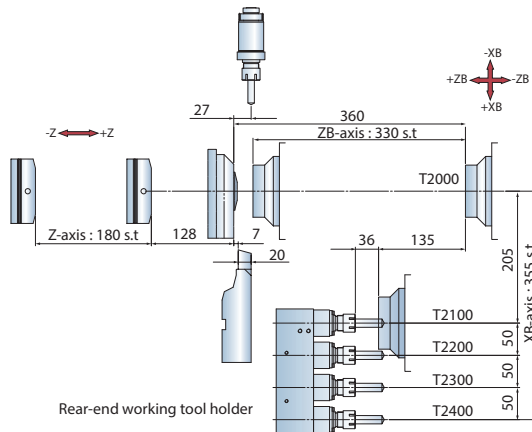

Bushless

O.D. tools X 5
live tools X 5

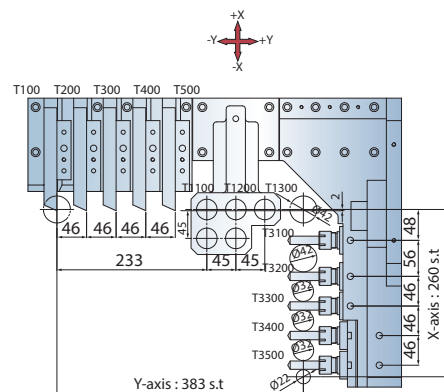
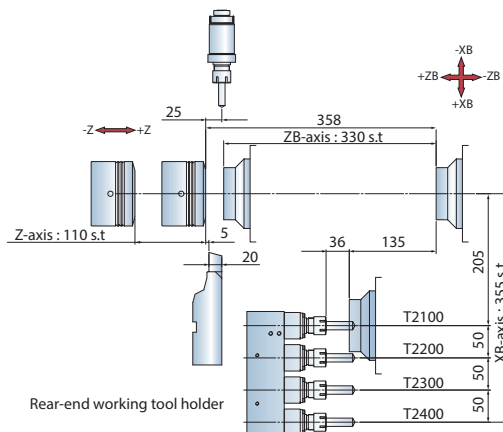

unit : mm

Bush

O.D. tools X 6
live tools X 4

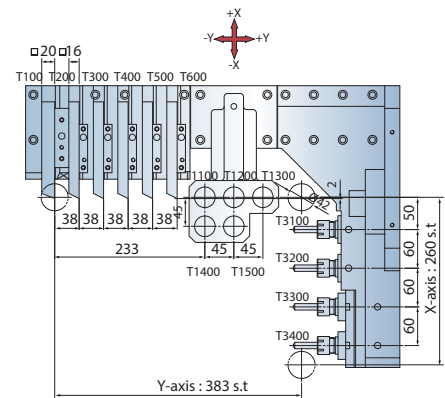
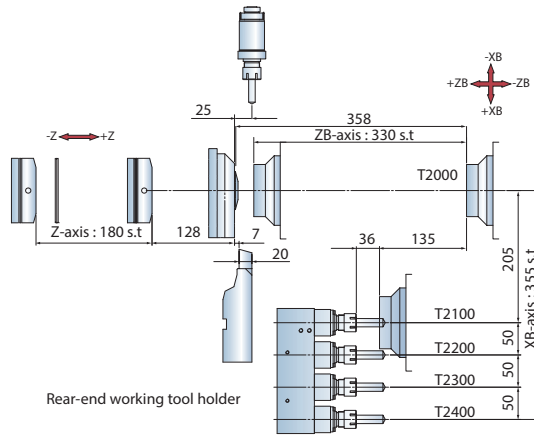

Bushless

O.D. tools X 6
live tools X 4

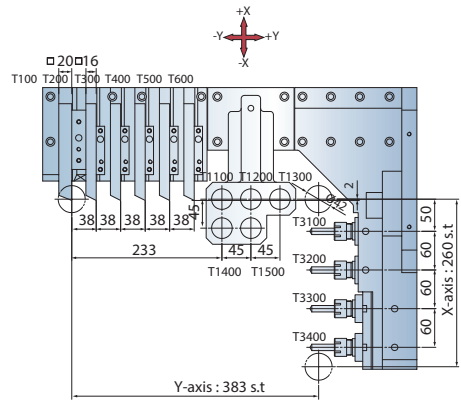
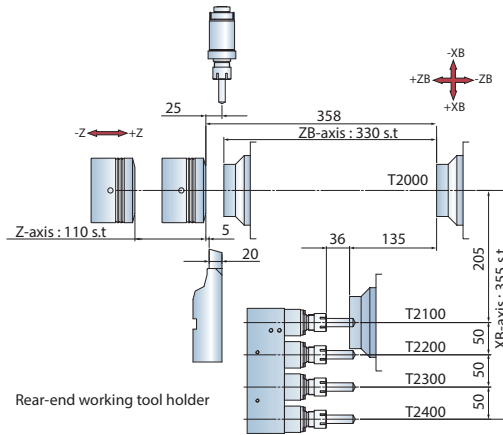

Bush

O.D. tools X 6
live tools X 5

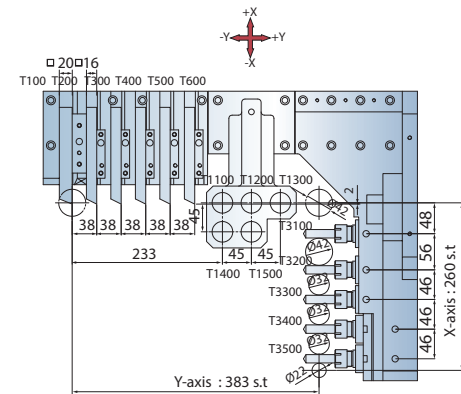
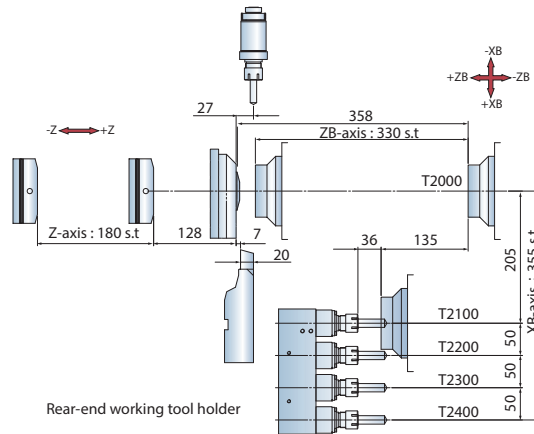

Bushless

O.D. tools X 6
live tools X 5

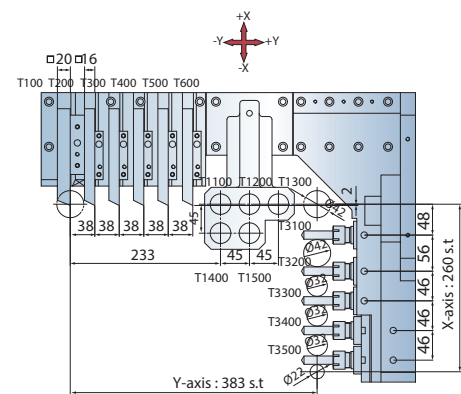
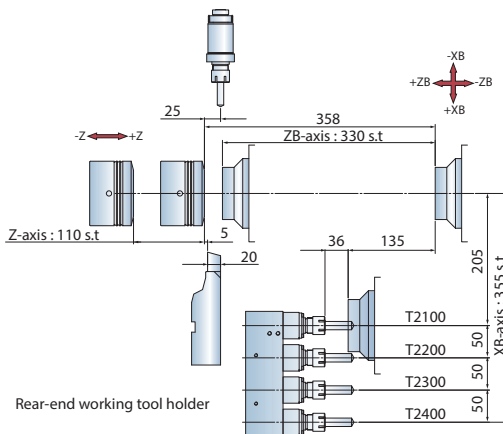

NC INTELLIGENCE **G.LINC 350** option

Advanced Hardware Combined with Intelligent Software, Makes Your Machine Smarter

- ▶ Advanced hardware
- ▶ Outstanding operability
- ▶ Streamlined programming
- ▶ High security and shortened machining setting
- ▶ Reliable continuous operation
- ▶ Shortened troubleshooting time
- ▶ Improved utilization rate
- ▶ 3D cutting simulation preview



Comprehensive Functions

Programming	Setting	Test-Run	Actual Production	Daily Used
Dynamic graphic display Program management Friendly programming environment Programming auxiliary Manual Guide <i>i</i> Embedded E-manual	3D advance tool path and cutting simulation	Tool load monitor Program check Smart balance detection 3D Real-time cutting simulation Interference check (31 <i>i</i> option needed)	Tool load monitor 3D Real-time cutting simulation Interference check (31 <i>i</i> option needed) Load monitoring	Safety signal viewer Fast alarm check productivity Productivity management Twin operation system switch Maintenance management NFC apply authority management and record



AIR BAG

Standard with air bag for maximum protection and also minimum the damage when machine crash which can save the cost of repair machines and production lost because of machine broken.

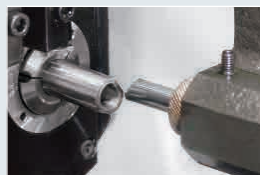
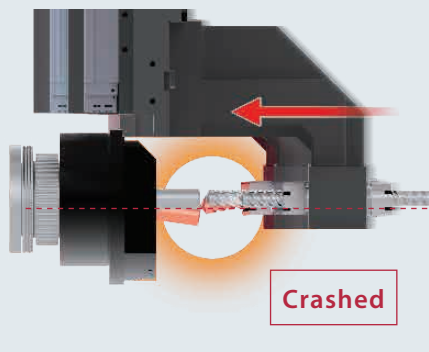

Equipped with air bag

Retract tools within 0.009 second

Machine crash → EMG mode → Servo motor reverse rotary within 0.009 second → Machine stop



Not equipped with air bag

after machine crashed, axes continue feeding, machine structure might get damaged seriously.

MACHINE SPECIFICATIONS

■ : Metric ■ : Inch

13

14

		SW-20	SW-32	SW-42
Working range	Max. machining diameter	Ø 20 mm 0.78"	Ø 32 mm 1.25"	Ø 42 mm 1.65"
	Max. turning length per chuck	220 / 50 mm 8.66" / 1.96" (Bush / Bushless)	315 / 80 mm 12.4" / 3.14" (Bush / Bushless)	180 / 110 mm 7.08" / 4.33" (Bush / Bushless)
O.D. tools	Number of tools	6	6	5 6
	Shank size	□ 12 mm 1/2"	□ 16 mm 5/8"	□ 20 mm 3/4" □ 20 mm 3/4" x 1 □ 16 mm 5/8" x 5
I.D. tools	Number of tools	4	4	5
	Sleeve size	ER16	ER 20	ER 20
	Max. drilling capacity	Ø 10 mm 0.39"	Ø 13 mm 0.51"	Ø 13 mm 0.51"
	Max. tapping capacity	M8 x P1.25	M12 x P1.75	M12 x P1.75
Cross live tools	Number of tools	5 ~10	5 ~10	4 ~ 6
	Max. live tooling speed	8,000 rpm	6,000 rpm	6,000 rpm
	Servo motor output	1.2 kW 1.61 HP	1.4 kW 1.88 HP	1.4 kW 1.88 HP
	Sleeve size	ER 16	ER 20	ER 20
	Max. drilling capacity	Ø 8 mm 0.31"	Ø 10 mm 0.39"	Ø 10 mm 0.39"
	Max. tapping capacity	M6 x P1.0	M8 x P1.25	M8 x P1.25
	Max. end mill capacity	Ø 10 mm 0.39"	Ø 13 mm 0.51"	Ø 13 mm 0.51"
Main spindle	Max. speed	10,000 rpm	7,000 rpm	6,000 rpm
	Spindle motor output (cont. / 30 min.)	2.2 / 3.7 kW 3 / 5 HP	5.5 / 7.5 kW 7.3 / 10 HP	5.5 / 7.5 kW 7.3 / 10 HP
	Min. indexing increment	0.001°		
X / Y / Z / XB / ZB axes rapids		30 m/min. 1,181 IPM		
NC controller		FANUC 31i		
Spindle center height		1,060 mm 41.73"	1,060 mm 41.73"	1,080 mm 42.52"
Coolant tank capacity		260 L 68 gal	425 L 112 gal	425 L 112 gal
Machine dimensions		2,710 x 1,470 x 1,940 mm 107" x 58" x 77"	2,930 x 1,550 x 2,030 mm 116" x 62" x 80"	2,930 x 1,550 x 2,140 mm 116" x 62" x 85"
Machine weight		2,300 Kg 5,100 lb	3,200 Kg 7,100 lb	3,300 Kg 7,300 lb

Backworking Tooling System

		SW-20	SW-32	SW-42
Rear-end machining capability	Max. chucking diameter	Ø 20 mm 0.78"	Ø 32 mm 1.25"	Ø 42 mm 1.65"
	Max. length for front ejection	80 mm 3.14"	130 mm 5.11"	110 mm 4.33"
	Max. parts projection length	30 mm 1.18"	50 mm 1.96"	50 mm 1.96"
Rear-end tools	Number of tools	4	4	4
	Max. live tooling speed	8,000 rpm	5,000 rpm	5,000 rpm
	Servo motor output	0.4 kW 0.54 HP	0.75 kW 1 HP	0.75 kW 1 HP
	Max. drilling capacity (I.D. tools)	Ø 8 mm 0.31"	Ø 13 mm 0.51"	Ø 13 mm 0.51"
	Max. drilling capacity (live tools)	Ø 5 mm 0.19"	Ø 6 mm 0.23"	Ø 6 mm 0.23"
	Max. tapping capacity (I.D. tools)	M8 x P1.25	M10 x P1.25	M10 x P1.25
	Max. tapping capacity (live tools)	M4 x P0.7	M5 x P0.8	M5 x P0.8
Sub-spindle	Max. sub-spindle speed	8,000 rpm	7,000 rpm	6,000 rpm
	Sub-spindle motor output (cont. / 30 min.)	1.5 / 2.2 kW 2 / 3 HP	2.2 / 3.7 kW 3 / 5 HP	3.7 / 5.5 kW 5 / 7.3 HP
	Min. indexing increment	0.001°		

Specifications are subject to change without notice.



GOODWAYCNC.com

GOODWAY MACHINE CORP.

HEADQUARTERS

No.13, 5th Road,
Taichung Industrial Park,
Taichung City, 407, Taiwan
E-mail : goodway@goodwaycnc.com

CENTRAL TAIWAN SCIENCE PARK BRANCH

No. 38, Keyuan Road,
Central Taiwan Science Park.Taichung,
Taichung City, 407, Taiwan
TEL : + 886-4-2463-6000
FAX : + 886-4-2463-9600

GOODWAY MACHINE (WUJIANG) CO.,LTD

No. 4888, East Lake Taihu Avenue, Wujiang
Economic and Technological Development Zone,
Jiangsu, China
Sales Hotline : + 86-512-8286-8068
Service Hotline : + 86-512-8286-8066
FAX : + 86-512-8286-8620
E-mail : goodway@goodwaycnc.cn