

Die komplette Lösung für kleine Teile
Ø2 bis Ø13 (16) mm

KMX 413

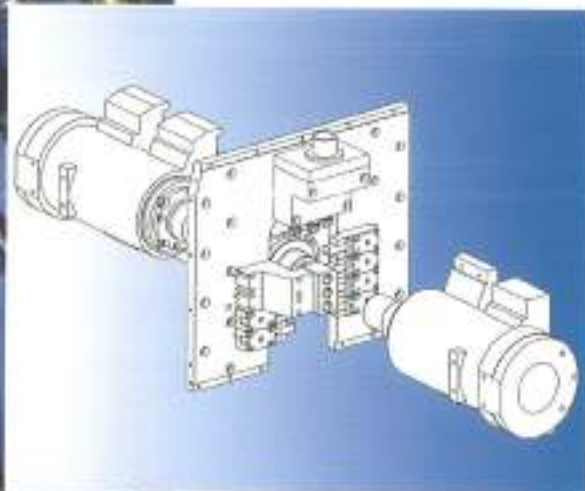

Mit einer **Standardausrüstung** bestehend aus **zwei numerisch gesteuerten Elektrospindeln**, **einem automatischen Stangenlademagazin** sowie **einer Einheit mit drei angetriebenen Werkzeugen**, **KMX 413** ist die Lösung für Drehteile von Ø2 bis Ø13 mm (bis Ø16 mm möglich durch andrehen des Materials).

KTMX 413 4 axis slidinghead machine

TECHNICAL DATA

Main Spindle

Max. bar capacity	Ø13mm
Spindle bore	Ø17mm
Electrospindle (100/60%)	3.7/5.5kW
Max. spindle speed	12 000rpm
Headstock stroke	130mm

Sub spindle

Max. bar capacity	Ø13mm
Spindle bore	Ø17mm
Electrospindle (100/60%)	2.2/3.7kW
Max. spindle speed	12 000rpm
Max. length of part inside the spindle	95mm
Max. length of part for front ejection	130mm

Powered tools

Number of stations	3
Max. speed :	
- on 2 stations	8 000rpm
- on 1 stations	2 600rpm

Pneumatic controls

Air pressure required	6bars
Connection by "banjo" coupling	Ø10mm

Coolant

Tank capacity	120l
Pressure	2bars

Automatic lubrication

Weight of the machine	2000kg
-----------------------	--------

Standard package with :

- 6 quick change external toolholder
- 1 internal toolholder block with 3 stations
- 1 main spindle with clamping device for single cone collet F20
- 1 sub spindle with clamping device for single cone collet F20
- 1 driven, mechanical, revolving guide bush devices.
- 1 powered tools unit with 3 stations
- 1 workpiece recuperator
- 1 barloader for bars 3,2 m

OPTIONS

- Long part evacuation device
- Swarf conveyor
- *C* axis on main spindle and sub spindle
- Rigid tapping on main and sub spindle

View on working area showing:

- the revolving guide bush
- the 3 powered tools unit
- the rack with the external an internal toolholders
- the sub spindle



The quick change cartridge for external tool with 12x12 shank.

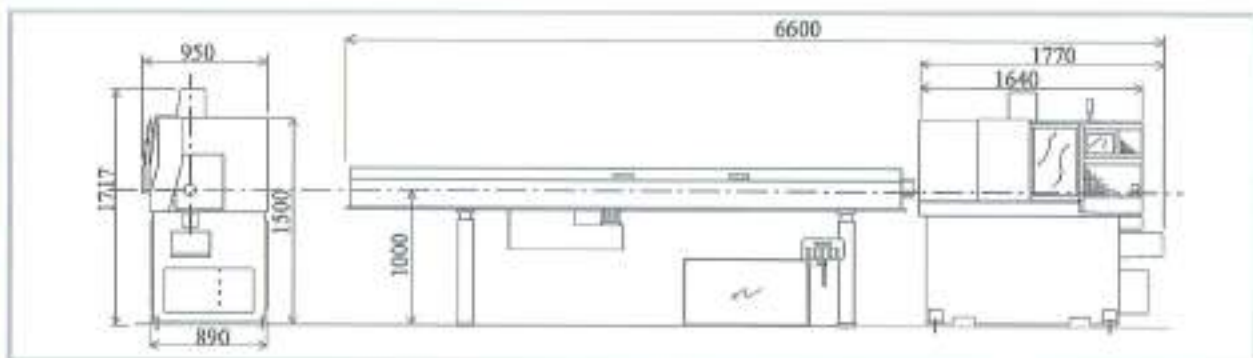

IN CONFORMITY WITH IEC SAFETY STANDARDS  THE MANUFACTURER RESERVES THE RIGHT TO CHANGE SPECIFICATIONS OF FEATURES WITHOUT NOTICE DUE TO TECHNICAL DEVELOPMENTS

MANURHINKMX
www.manurhin-kmx.com

ZI DE LA DOLLER - BP N°31 - 68520 BURNHUPFLE-HAUT - FRANCE
TEL. 33 (0)3 89 62 33 33 - FAX 33 (0)3 89 53 44 84
www.manurhin-kmx.com • E-MNL : info@manurhin-kmx.com