

Instructions

SUITCASE® Trifold® AS Ramp

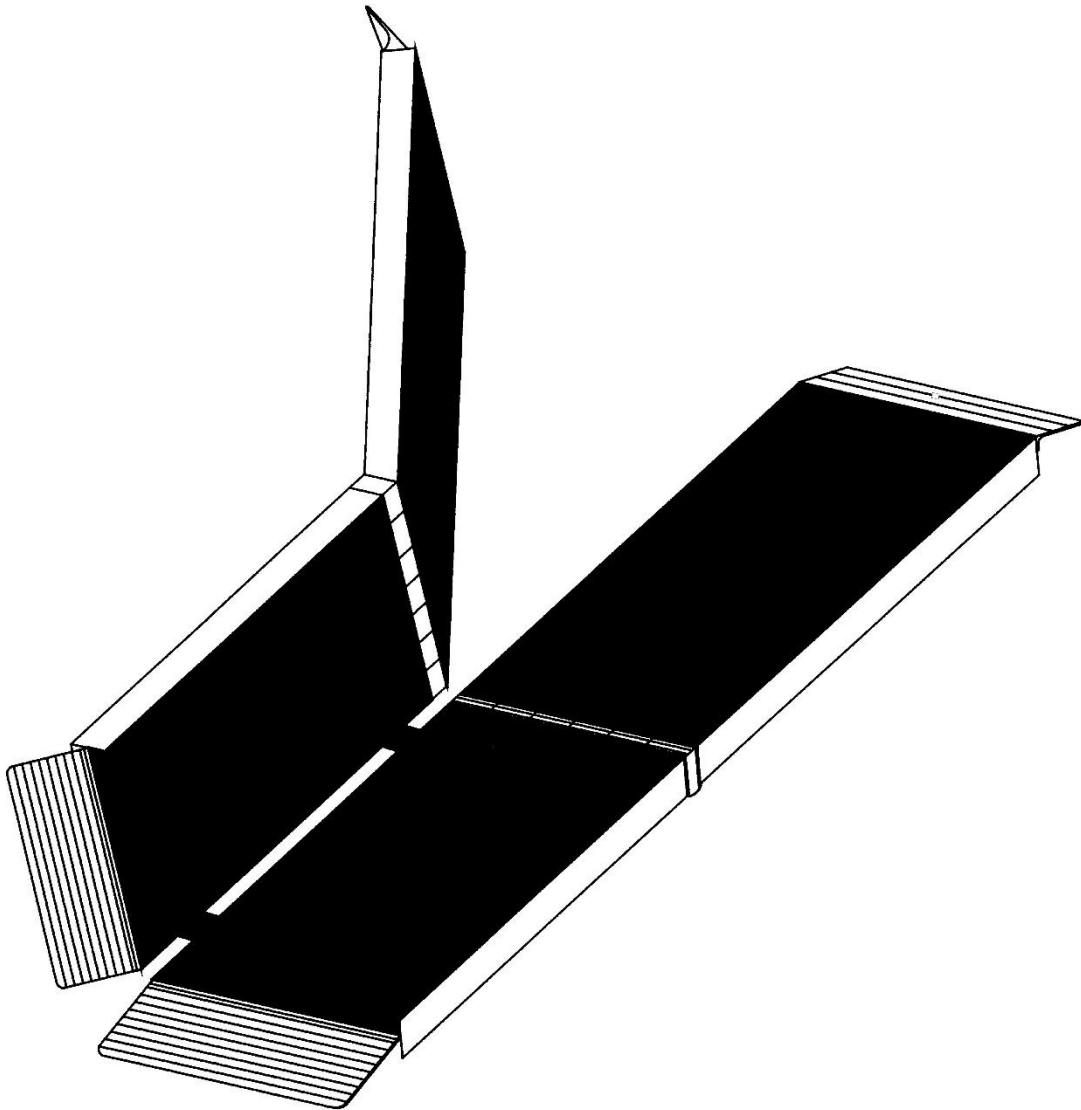

Portable ramp for temporary or semi-permanent use



Patented.
LIFETIME WARRANTY. Please register at www.ezaccess.com/warranty-satisfaction.
CE Technical Files kept at: Enable Access, Marshmoor Works Great North Road, North Horth Mymms Hatfield, AL9 5SD, UK.
© EZ-ACCESS®, a division of Homecare Products, Inc. All rights reserved.
All text and images contained in this document are proprietary and may not be shared, modified, distributed, reproduced, or reused without the express written permission of EZ-ACCESS.

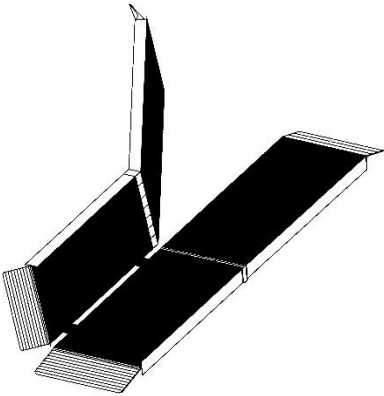
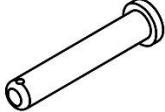
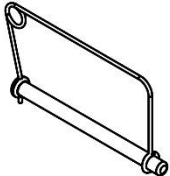

PACKAGE CONTENTS

QTY	DESCRIPTION	IMAGE*
1	EZ-ACCESS® SUITCASE® TRIFOLD® AS RAMP	
2	CLEVIS PIN	
2	HINGE PIN	
1	INSTRUCTIONS	

* IMAGES NOT SHOWN TO ACTUAL SIZE

SYMBOLS AND WARNINGS

- ⚠ The **WARNING** symbol indicates a potentially hazardous condition/situation. The warnings throughout this document, and on your equipment, if any, are for the protection of people and property. Failure to abide by warnings will result in a waiver of all liabilities, loss of your warranty, and could result in equipment damage and or failure, property damage, risk of serious bodily injury, and or death to operators, riders, and those nearby. The symbol may appear in various colors and in conjunction with other symbols.
- 👉 The **NOTE** symbol indicates important information. Failure to obey all notes could result in improper operation, less-than-optimum equipment performance, and at the sole discretion of the equipment manufacturer, may void your warranty. The symbol may appear in various colors and in conjunction with other symbols.

WARNINGS!

- ⚠ Maximum weight capacity is 800 lbs.; never exceed weight capacity.
- ⚠ Prior to assembly and use, read and follow all instructions, warnings, and labels. Following all instructions and obeying all warnings before and during use is necessary for safe operation. For additional information or to obtain replacement copies of instructions or labels, call 1-800-451-1903.
- ⚠ For wheelchairs and scooters only; not for commercial use.
- ⚠ Before use, refer to your mobility equipment's owner guide for acceptable ramp usage, including proper slope/incline, chair direction, etc.; never exceed its recommendations.
- ⚠ Only use the ramp with a qualified helper and always use a lap belt.
- ⚠ Before each use, check the ramp for worn, loose, or damaged parts. If you find any of these conditions, do not use the ramp. Contact your dealer for service or repairs. Failure to do so may cause injury.
- ⚠ Do not use the ramp if it is damaged or unstable.
- ⚠ Do not tamper with, attempt to repair, or modify any portion of the ramp.
- ⚠ Use caution when folding and unfolding ramp to avoid all potential pinch points.
- ⚠ Ensure that the landing the ramp will be placed on is substantial and of sound construction.
- ⚠ Ensure that each top lip transition plate fully overlaps a secure, unobstructed, level landing enough to safely install clevis pins or other anchoring hardware and rests firmly against the landing prior to use. If a secure, unobstructed, level landing cannot be attained, do not use the ramp.
- ⚠ Ensure that the ramp is securely anchored before each use.
- ⚠ The ramp surface may be slippery in wet conditions; use caution if the surface is wet as traction may be reduced.
- ⚠ Do not use the ramp if its surface is covered with ice, snow, dirt, leaves, or other debris. Remove all accumulations and sweep the surface clean before use.
- ⚠ Improper use of product could result in serious injury.

CARE AND MAINTENANCE

1. Before each use, check the ramp for worn, loose, or damaged parts. If you find any of these conditions, do not use the ramp.
 - ⚠ Do not tamper with, attempt to repair, or modify any portion of the ramp.
2. Keep the ramp surface clear of ice, snow, dirt, leaves, and other debris. For ice and or snow, remove all accumulations and sweep surface clean. For dirt, leaves, and other debris, sweep surface or wash with a soft bristle brush and non-alkaline detergent; rinse well.
 - ⚠ The ramp surface may be slippery in wet conditions. Use caution if surface is wet as traction may be reduced.
3. Store the ramp in a cool, dry place when not in use.

GETTING STARTED

1. Read this instruction manual in its entirety before use and follow all instructions before and during use.
2. Before use, refer to your mobility equipment's owner guide for acceptable ramp usage, including proper slope/incline, chair direction, etc.; never exceed its recommendations.
3. Before each use, check the ramp for worn, loose, or damaged parts. If you find any of these conditions, do not use the ramp.
4. Confirm that all package contents are present. Open the shipping box and inspect for damaged or missing parts. If damaged or missing parts are noted, do not use the ramp.

SET UP AND USE

1. The ramp is shipped fully assembled. To unfold for use, position the ramp approximately its full length out from a secure, unobstructed, level landing.
2. Unfold the first top half of the ramp (labeled TOP) toward the upper landing and place the ramp so that the top lip transition plate fully overlaps the landing and is securely supporting the ramp (FIG. 1).
3. Unfold the second top half of the ramp so that both halves are fully extended lengthwise, with one half positioned face down on top of the other (FIG. 2).
4. Complete the ramp opening, exposing the entire applied slip-resistant tread surface, then center the ramp on the upper landing (FIG. 3).
5. Ensure that the surface area of each top lip transition plate fully overlaps a secure, unobstructed, level landing enough to safely install clevis pins (provided) or other anchoring hardware and rests firmly against the landing (FIG. 4).
 - a. If the top lip transition plates are not long enough to fully overlap a secure, unobstructed, level landing, a SUITCASE® Top Lip Extension ('TLE') is an available option (sold separately). See 'OPTIONAL ACCESSORY' section for more information.
6. Securely anchor the ramp to the upper landing (FIG. 3).
 - a. TEMPORARILY: To attach temporarily using the provided clevis pins, position the ramp securely and use the hole in each top lip transition plate as a template to drill corresponding 1/4" holes into the upper landing (ensure drilled holes are deep enough to fully seat each clevis pin). Fully insert a clevis pin (FIG. 4) through the pre-drilled hole in each top lip transition plate and into the corresponding drilled holes in the landing.
 - b. SEMI-PERMANENTLY: To attach semi-permanently using non-provided hardware, position the ramp securely and use the hole in each top lip transition plate as a template to identify anchor locations. Install non-provided hardware flush with the surface of each top lip transition plate and ensure that it does not create a hazard.
 - ▲ Ensure that the ramp is securely anchored before each use.
 - ▲ When using non-provided hardware, follow hardware manufacturer's installation instructions, ensuring that hardware is of sufficient type and size to prevent ramp slippage or undo movement.

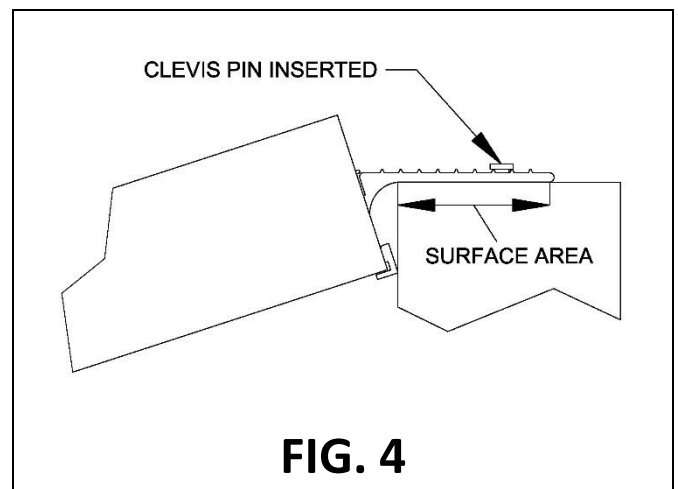
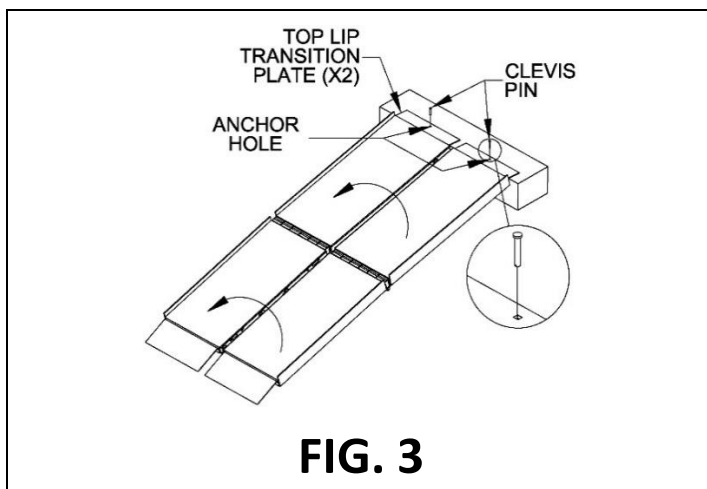
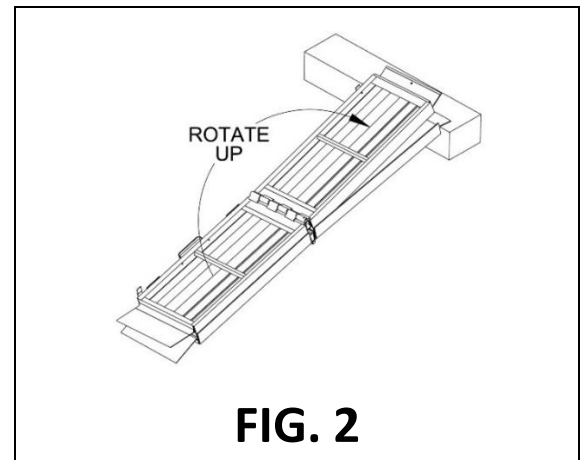
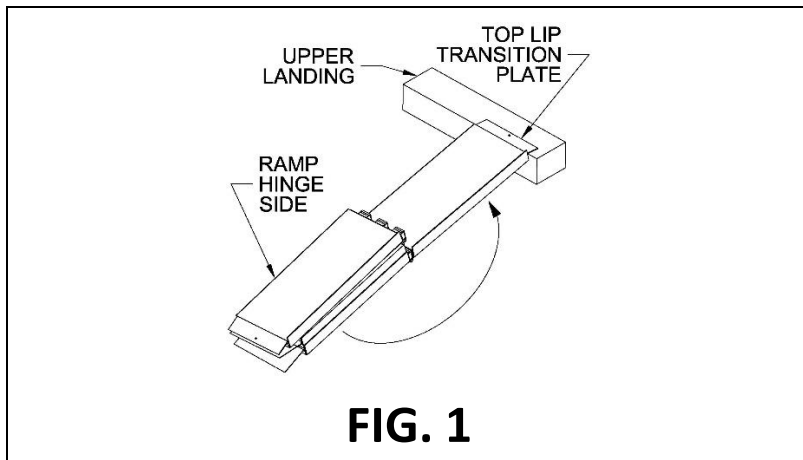

7. For stowage and transportation, or for loading unoccupied mobility equipment with a wider wheelbase, the ramp can be separated into two halves (FIG. 5) by removing (2 ea.) hinge bolts and nylon locknuts (FIG. 6).
 - ⚠ The ramp may be separated for use when loading or unloading unoccupied mobility equipment only.
 - ⚠ When the ramp is used with occupied mobility equipment, ensure that the ramp halves are rejoined as described in 'STEP 10'.
8. Place the two ramp halves in a position that facilitates the load being centered on each half (FIG. 5).
 - ⚠ Always keep ramp loads on the centerlines (FIG. 5).
9. Ensure that the surface area of both top lip transition plates fully overlap a secure, unobstructed, level landing enough to safely install clevis pins (provided) or other anchoring hardware, and rests firmly against the landing (FIG. 4).
10. Securely anchor each ramp half before use (FIG. 5); refer back to 'STEP 6' for anchoring procedures.
11. The ramp halves can be rejoined using provided (2 ea.) hinge pins or (2 ea.) original hinge bolts and nylon locknuts by positioning the ramp as shown (FIG. 6).
 - a. Align hinges, then insert either a hinge pin or hinge bolt and nylon locknut into each hinge assembly.
 - b. If using hinge pins, ensure that the pins are closed and that the spring section of the pin is on the underside (non-treaded side) of the ramp. If using hinge bolts and nylon locknuts, tighten securely.
 - 👉 When hinge pins or hinge bolts and nylon locknuts are not in use, store in one side of the hinge.
 - ⚠ Be sure to always rejoin the ramp halves using the provided (2 ea.) hinge pins or (2 ea.) original hinge bolts and nylon locknuts.
12. To prevent the ramp halves from swinging open when carrying the ramp, locate both of the hook and loop tabs (found on the non-treaded side of the ramp, near the top and bottom edges) and remove each top protective cover.
 - a. Press the hook and loop tabs together and ensure that they are firmly connected (FIG. 6).

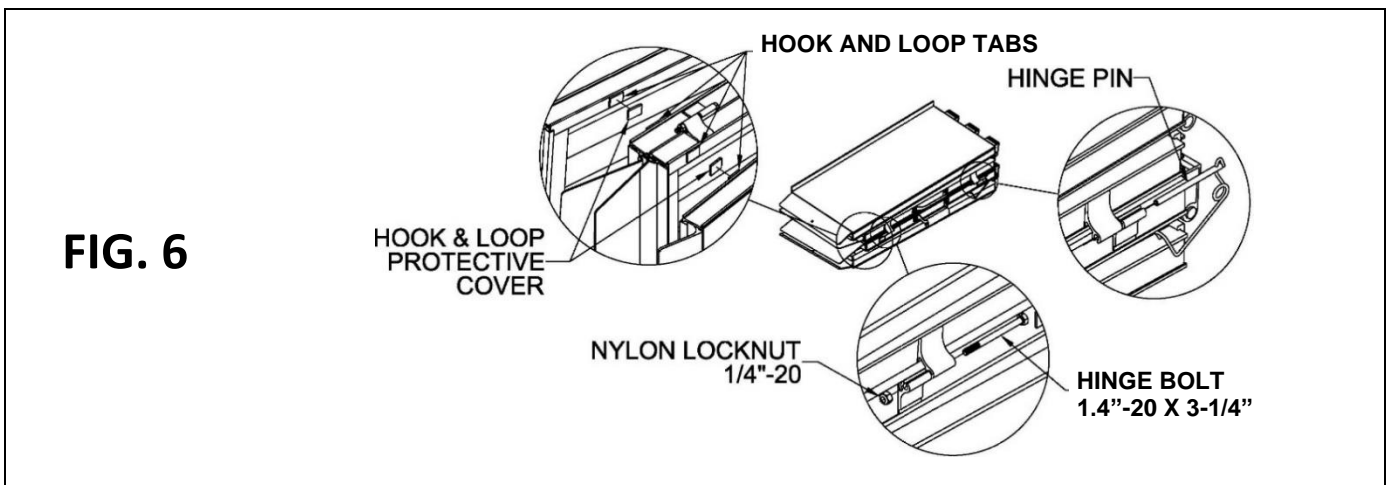
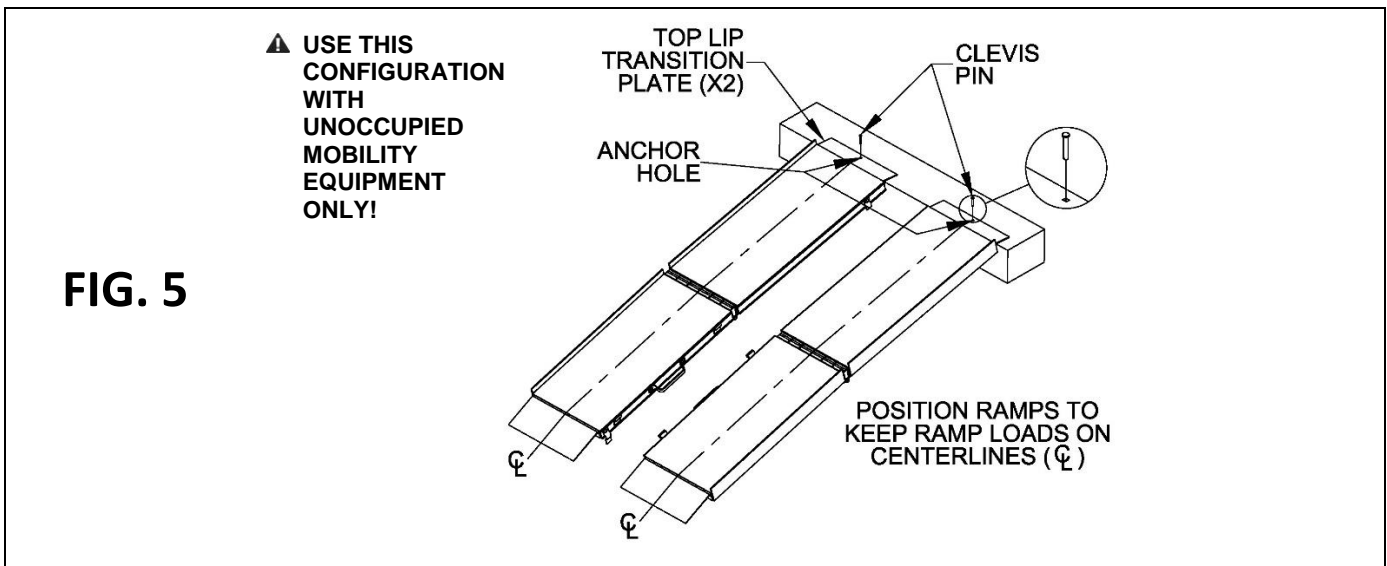

OPTIONAL ACCESSORY

1. If the ramp's top lip transition plates are not long enough to fully overlap a secure, unobstructed, level landing, a SUITCASE® Top Lip Extension ('TLE') is an available option that increases the standard 3" reach of the top lip transition plates to 9", in many cases, allowing the ramp to clear an obstruction to create a smooth transition. Visit www.ezaccess.com or call 1-800-451-1903 for more information.

- ▲ Use of the TLE reduces overall ramp weight capacity to 500 lbs.; never exceed weight capacity.
- ▲ If a secure, unobstructed, level landing cannot be attained, do not use the ramp.

INCLINE CHART

- ▲ An incline chart is provided below, however, it is intended only as a guideline. Before use, refer to your mobility equipment's owner guide for acceptable ramp usage, including proper slope/incline, chair direction, etc.; never exceed its recommendations.

		RAMP LENGTH								
		2'	3'	4'	5'	6'	7'	8'	9'	10'
RISE	3"	7.2°	4.8°	3.6°	2.9°	2.4°	2.0°	1.8°	1.6°	1.4°
	4"	9.6°	6.4°	4.8°	3.8°	3.2°	2.7°	2.4°	2.1°	1.9°
	5"	12°	8.0°	6.0°	4.8°	4.0°	3.7°	3.0°	2.7°	2.4°
	6"	14.5°	9.6°	7.2°	5.7°	4.8°	4.1°	3.6°	3.2°	2.9°
	7"		11.2°	8.4°	6.7°	5.6°	4.8°	4.2°	3.7°	3.3°
	8"		12.8°	9.6°	7.7°	6.4°	5.5°	4.8°	4.2°	3.8°
	9"		14.5°	10.8°	8.6°	7.2°	6.2°	5.4°	4.8°	4.3°
	10"			12.0°	9.6°	8.0°	6.8°	6.0°	5.3°	4.8°
	12"			14.5°	11.5°	9.6°	8.2°	7.2°	6.4°	5.7°
	14"				13.5°	11.2°	9.6°	8.4°	7.4°	6.7°
	16"					12.8°	11.0°	9.6°	8.5°	7.7°
	18"					14.5°	12.4°	10.8°	9.6°	8.6°
	20"						13.8°	12.0°	10.7°	9.6°
	22"							13.2°	11.8°	10.6°
	24"							14.5°	12.8°	11.5°
	26"								13.9°	12.5°
28"								15.0°	13.5°	
30"									14.5°	

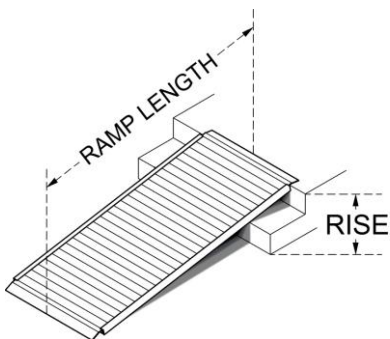

TO ESTABLISH THE PROPER RAMP LENGTH

1. Determine the incline that your chair is designed to climb.
2. Measure the rise (distance from top step, porch, van, etc. to the ground).
3. Refer to Incline Chart to find proper ramp length.

- ▲ At any incline, use ramp only with a qualified helper and always use your lap belt.