



# 15 Cylinder Pallet 6075

For trailers and trucks with a tomb style receiver



ProRack manufactures cylinder pallets for a wide variety of delivery trucks and trailers compatible with many tomb, picket and nesting systems found in the industry. ProRack's cradle and manifold expertise combined with steel product manufacturing volume result in high quality and competitive solutions for your cylinder distribution requirements.

## Outstanding Cylinder Pallet Features

- Designed to handle up to 15 large high pressure cylinders.
- Heavy duty construction with durable powder coated finish for years of service life. Galvanizing option available.
- This pallet is commonly used with major gas producers fleet trucks. Custom pallets are available to fit your exact dimensions.

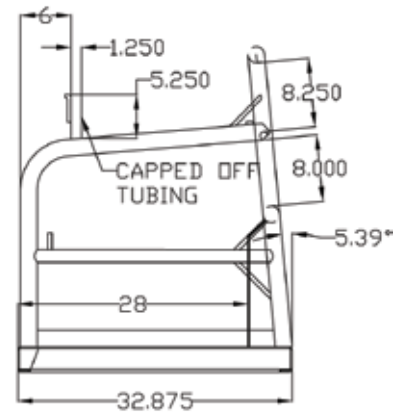
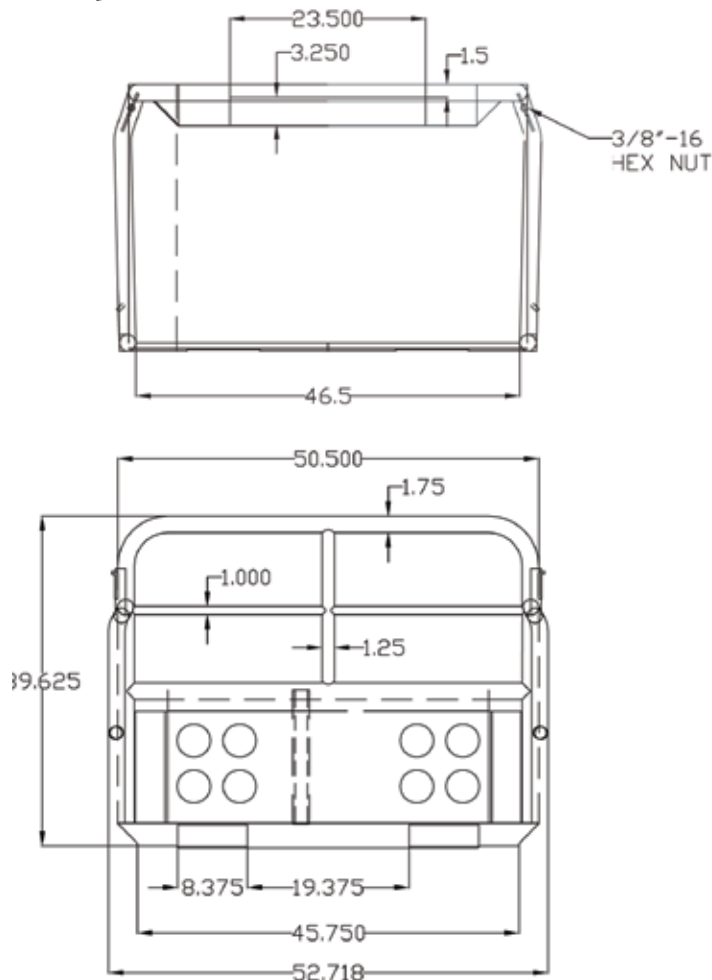

### ProRack 15 Cylinder Pallet System Ordering Chart

Part Number	Description	Width	Depth	Height	Weight
#	''	W	D	H	lbs
Pallet-6075	ProRack Cylinder Pallet with Tomb Receiver	46.5"	32.875"	39.625"	250 lbs

\* Ratchet straps sold separate.