

GOIZPER

YOUR PARTNER
IN POWER TRANSMISSION

PARALLEL SHAFTS INDEXERS

INDEXEURS A ARBRES PARALLELES

UIPE - 45 / 65 / 80 / 105

UIP - 125 / 160 / 200 / 400

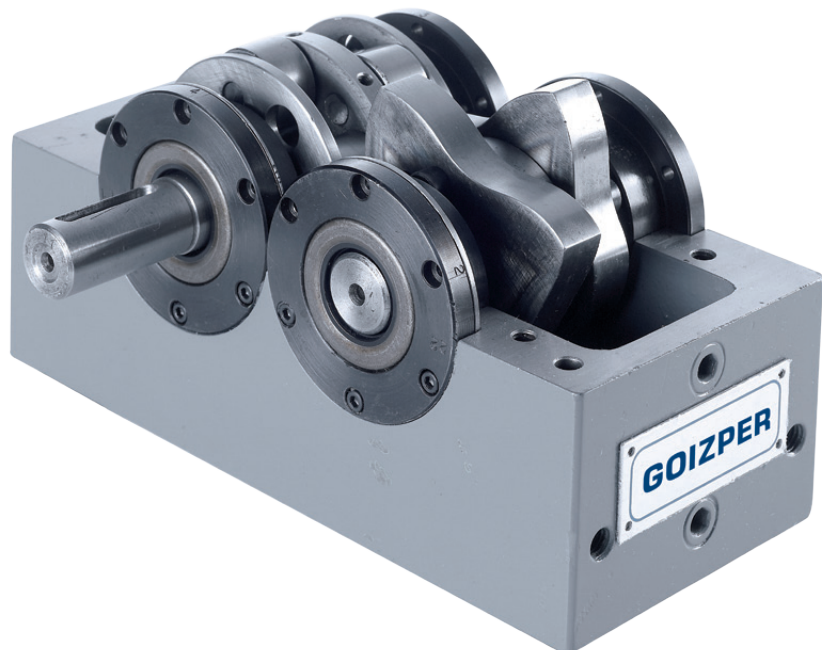

UIPE 45

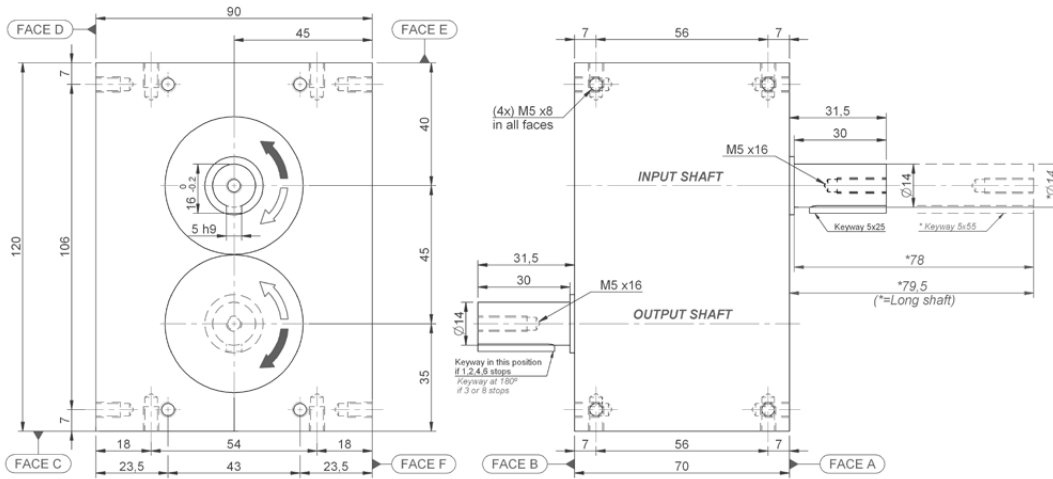

UIPE 45	
Repeatability Répétabilité	± 0,015 mm on/sur Ø 35
Indexing accuracy Précision d'indexage	± 0,030 mm on/sur Ø 35
Maximum allowable axial load Charge axiale max. admissible	95 N
Maximum allowable tilting torque Couple de basculement max. admissible	11 Nm
Maximum allowable radial load Charge radiale max. admissible	295 N
Weight Poids de l'indexeur	~ 5 Kg

UIPE 65

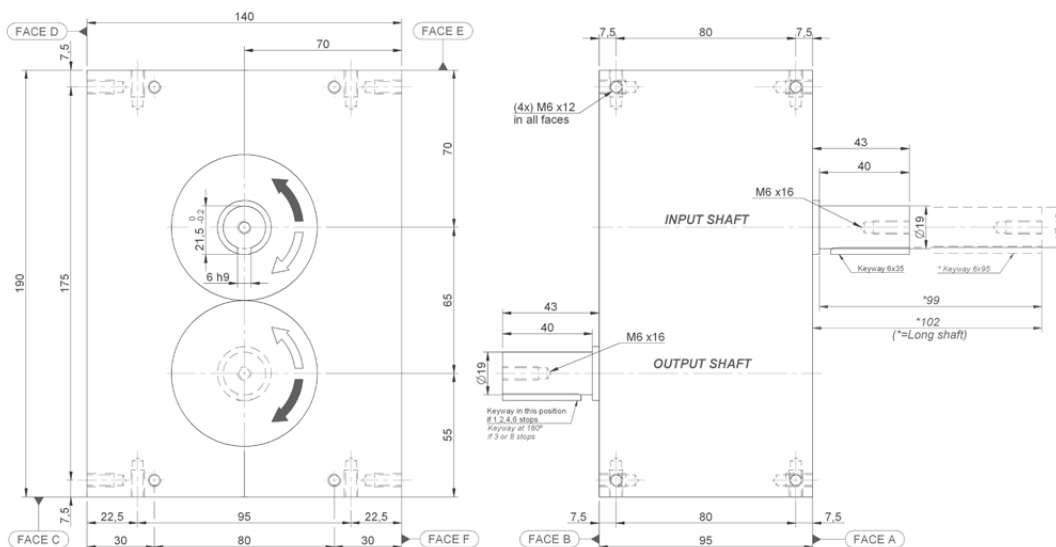

UIPE 65	
Repeatability Répétabilité	± 0,015 mm on/sur Ø 50
Indexing accuracy Précision d'indexage	± 0,030 mm on/sur Ø 50
Maximum allowable axial load Charge axiale max. admissible	315 N
Maximum allowable tilting torque Couple de basculement max. admissible	27 Nm
Maximum allowable radial load Charge radiale max. admissible	645 N
Weight Poids de l'indexeur	~ 15 Kg

UIPE 80

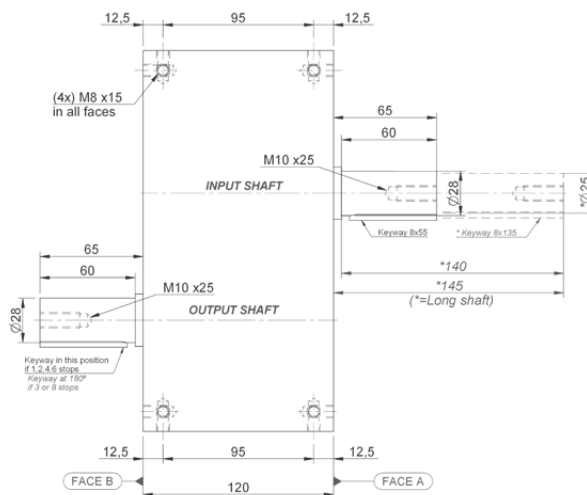
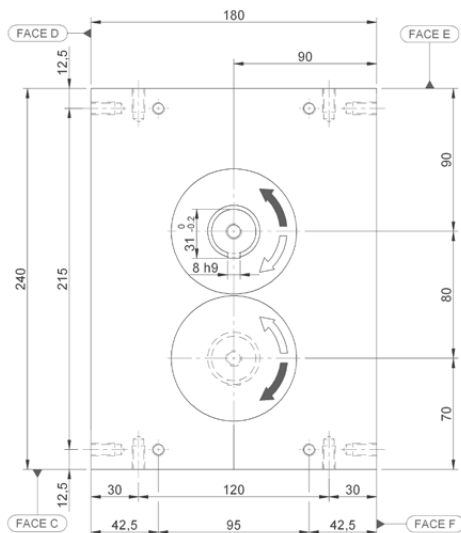

UIPE 80	
Repeatability Répétabilité	± 0,015 mm on/sur Ø 65
Indexing accuracy Précision d'indexage	± 0,030 mm on/sur Ø 65
Maximum allowable axial load Charge axiale max. admissible	745 N
Maximum allowable tilting torque Couple de basculement max. admissible	85 Nm
Maximum allowable radial load Charge radiale max. admissible	1.395 N
Weight Poids de l'indexeur	~ 29 Kg

UIPE 105

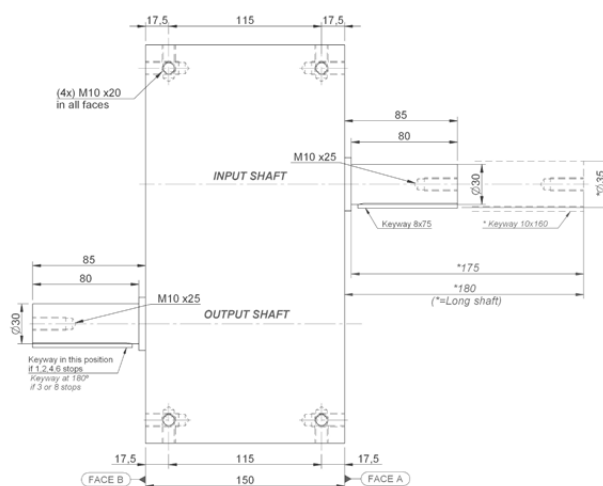
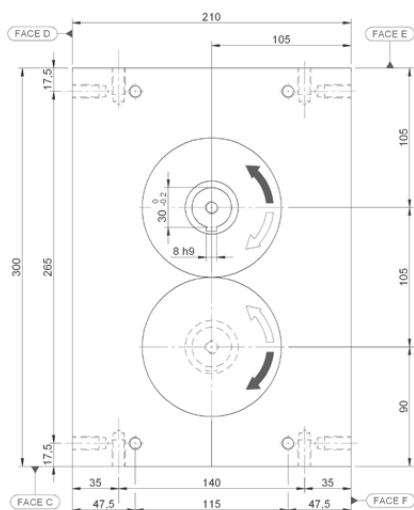

UIPE 105	
Repeatability Répétabilité	± 0,015 mm en/auf Ø 80
Indexing accuracy Précision d'indexage	± 0,030 mm on/sur Ø 80
Maximum allowable axial load Charge axiale max. admissible	1.095 N
Maximum allowable tilting torque Couple de basculement max. admissible	165 Nm
Maximum allowable radial load Charge radiale max. admissible	1.990 N
Weight Poids de l'indexeur	~ 50 Kg

UIP 125

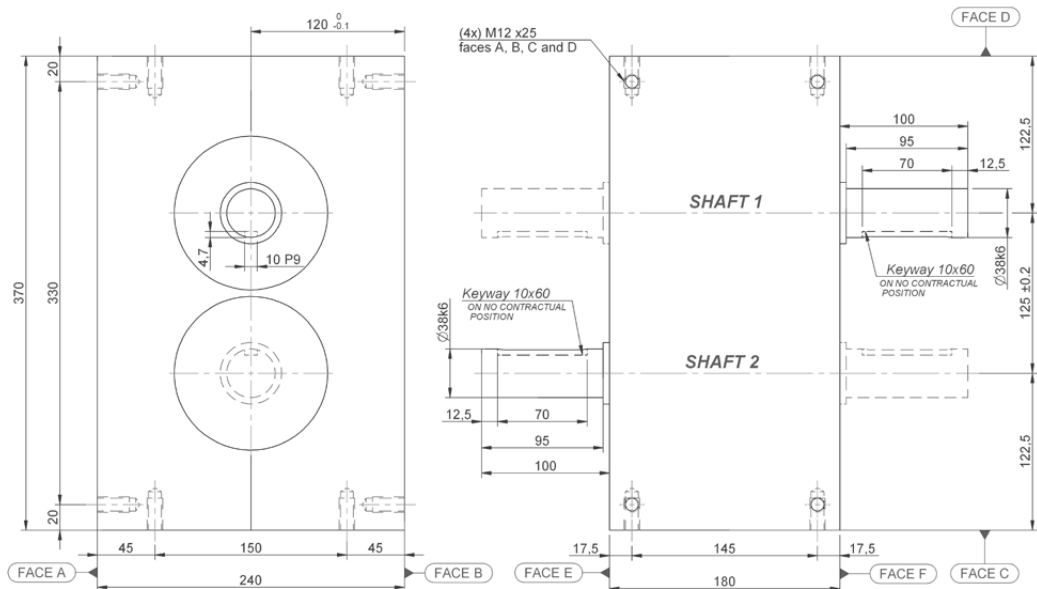

UIP 125	
Repeatability Répétabilité	± 0,015 mm on/sur Ø 110
Indexing accuracy Précision d'indexage	± 0,030 mm on/sur Ø 110
Maximum allowable axial load Charge axiale max. admissible	1.590 N
Maximum allowable tilting torque Couple de basculement max. admissible	2.550 Nm
Maximum allowable radial load Charge radiale max. admissible	2.700 N
Weight Poids de l'indexeur	~ 100 Kg

UIP 160

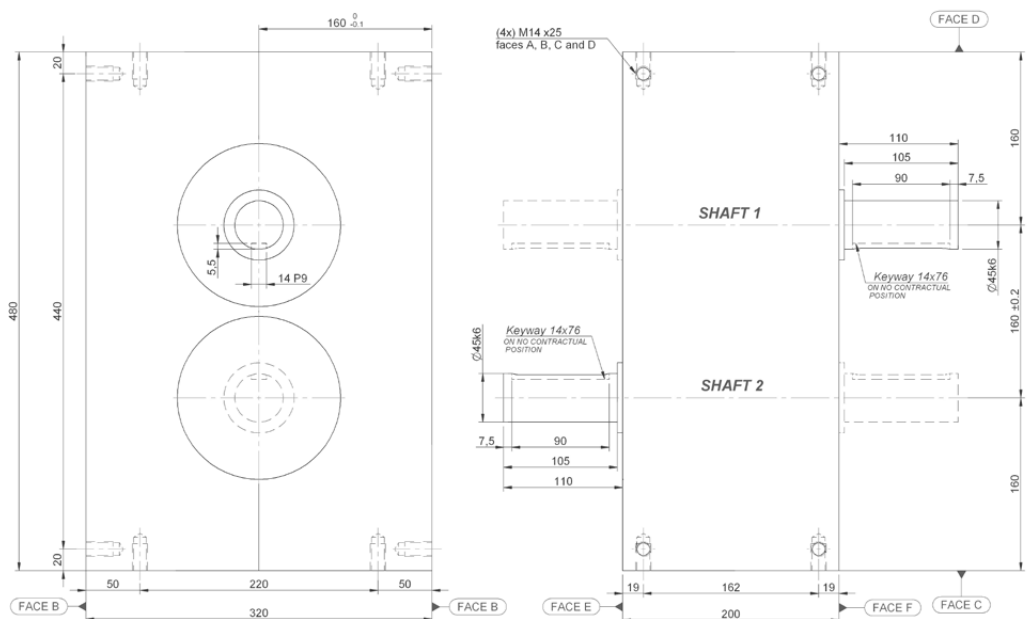

UIP 160	
Repeatability Répétabilité	± 0,015 mm on/sur Ø 140
Indexing accuracy Précision d'indexage	± 0,030 mm on/sur Ø 140
Maximum allowable axial load Charge axiale max. admissible	3.950 N
Maximum allowable tilting torque Couple de basculement max. admissible	1.030 Nm
Maximum allowable radial load Charge radiale max. admissible	7.270 N
Weight Poids de l'indexeur	~ 160 Kg

UIP 200

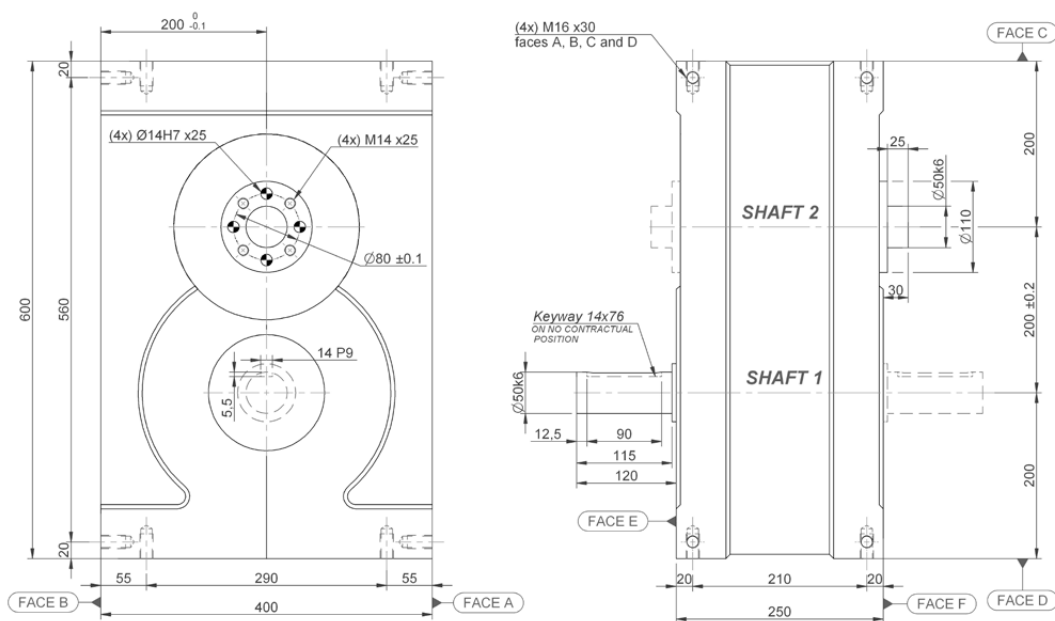

UIP 200	
Repeatability Répétabilité	$\pm 0,015$ mm on/sur $\varnothing 160$
Indexing accuracy Précision d'indexage	$\pm 0,030$ mm on/sur $\varnothing 160$
Maximum allowable axial load Charge axiale max. admissible	6.780 N
Maximum allowable tilting torque Couple de basculement max. admissible	1.910 Nm
Maximum allowable radial load Charge radiale max. admissible	11.850 N
Weight Poids de l'indexeur	~ 360 Kg

UIP 400

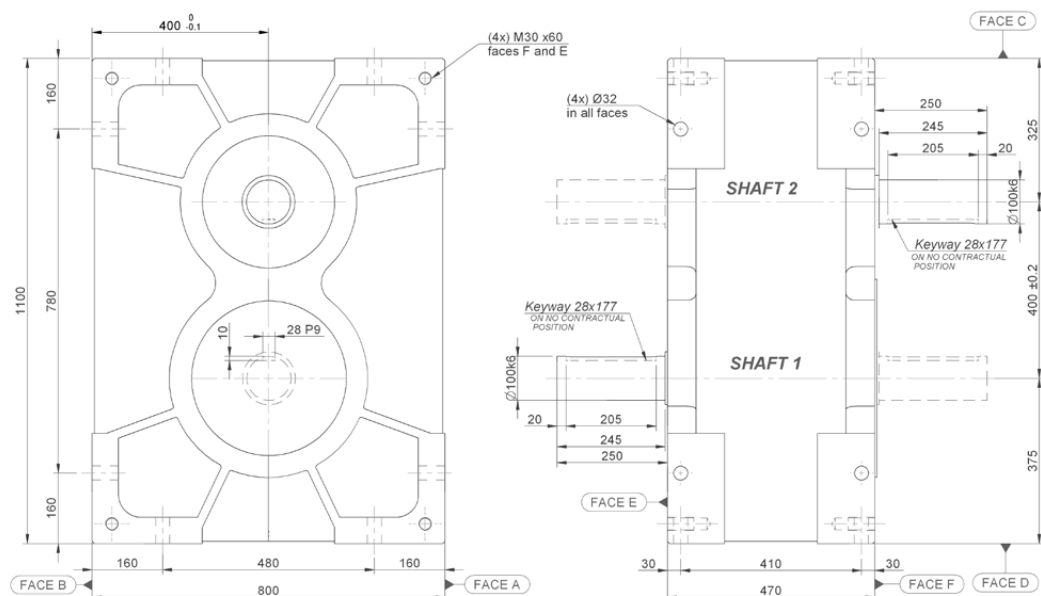

UIP 400	
Repeatability Répétabilité	$\pm 0,015$ mm on/sur $\varnothing 330$
Indexing accuracy Précision d'indexage	$\pm 0,030$ mm on/sur $\varnothing 330$
Maximum allowable axial load Charge axiale max. admissible	24.200 N
Maximum allowable tilting torque Couple de basculement max. admissible	11.300 Nm
Maximum allowable radial load Charge radiale max. admissible	43.300 N
Weight Poids de l'indexeur	~ 900 Kg

GOIZPER

● GOIZPER GROUP

Antigua, 4
20577 Antzuola
Gipuzkoa - Spain

Tel: + 34 943 78 60 00
goizper@goizper.com

● GOIZPER FRANCE

Espace d'Activités Becquerel
15, Avenue Henri Becquerel
51000 Châlons en Champagne
France

Tel: + 33 (0)3 26 21 08 39
goizperfrance@goizper.com

● GOIZPER GmbH

Bevertalstr. 20
42499 Hückeswagen
Deutschland

Tel.: +49 (0) 2192 935 99 03
goizperdeutschland@goizper.com

● GOIZPER TRANSMISSION MACHINERY
(WUXI) CO., LTD.

No. 3 Workshop, Fengneng Road,
Wind Power Science & Technology
Industrial Park,
Huishan Economic Development Zone,
214174 Wuxi, Jiangsu - China

Tel: +86 186 217 020 36
goizperchina@goizper.com



Goizper Group
Growing through cooperation

www.goizper.com