

GOIZPER

YOUR PARTNER
IN POWER TRANSMISSION

COMPACT PLATE INDEX DRIVES

TABLES D'INDEXAGE A CAME GLOBIQUE

PIC - 100 / 125 / 160 / 200 / 250 / 315

PIM - 100 / 175



PIC 100

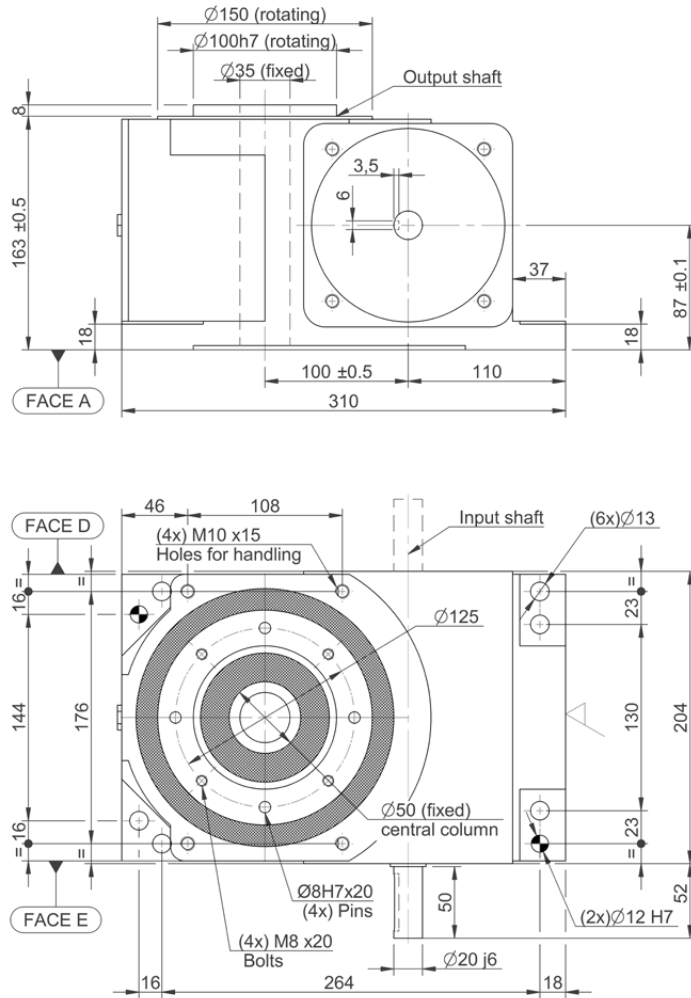

PIC 100	
Repeatability Répétabilité	$\pm 0,009$ mm on/sur $\varnothing 150$
Indexing accuracy Précision d'indexage	$\pm 0,017$ mm on/sur $\varnothing 150$
Maximum allowable axial load Charge axiale max. admissible	15.367 N
Maximum allowable tilting torque Couple de basculement max. admissible	282 Nm
Maximum allowable radial load Charge radiale max. admissible	2.000 N
Weight with moto reducer Poids de l'indexeur motorisé	~ 60 Kg

PIC 125

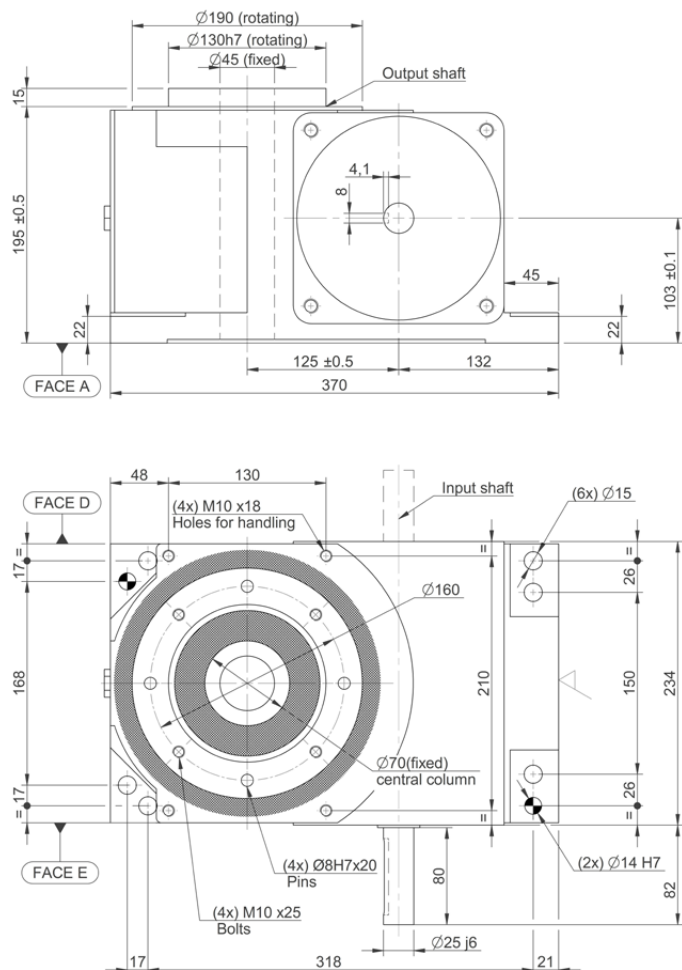

PIC 125	
Repeatability Répétabilité	$\pm 0,008$ mm on/sur $\varnothing 190$
Indexing accuracy Précision d'indexage	$\pm 0,017$ mm on/sur $\varnothing 190$
Maximum allowable axial load Charge axiale max. admissible	24.604 N
Maximum allowable tilting torque Couple de basculement max. admissible	591 Nm
Maximum allowable radial load Charge radiale max. admissible	3.500 N
Weight with moto reducer Poids de l'indexeur motorisé	~ 100 Kg

PIC 160

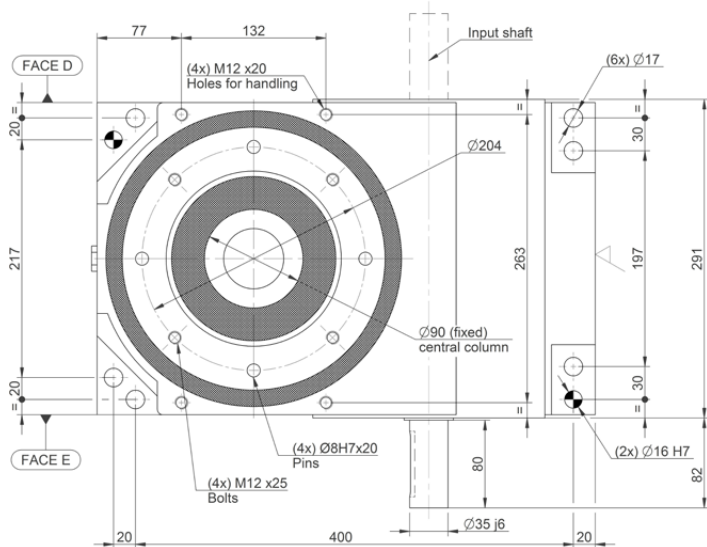
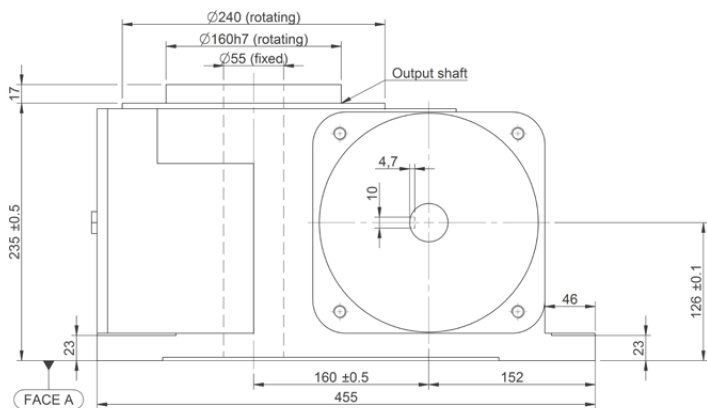

PIC 160	
Repeatability Répétabilité	$\pm 0,008$ mm on/sur $\varnothing 240$
Indexing accuracy Précision d'indexage	$\pm 0,017$ mm on/sur $\varnothing 240$
Maximum allowable axial load Charge axiale max. admissible	31.391 N
Maximum allowable tilting torque Couple de basculement max. admissible	1.015 Nm
Maximum allowable radial load Charge radiale max. admissible	5.000 N
Weight with moto reducer Poids de l'indexeur motorisé	~ 120 Kg

PIC 200

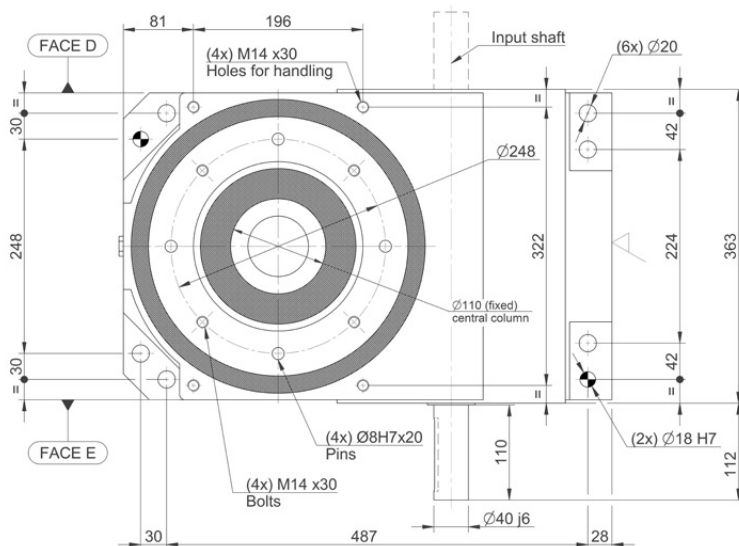
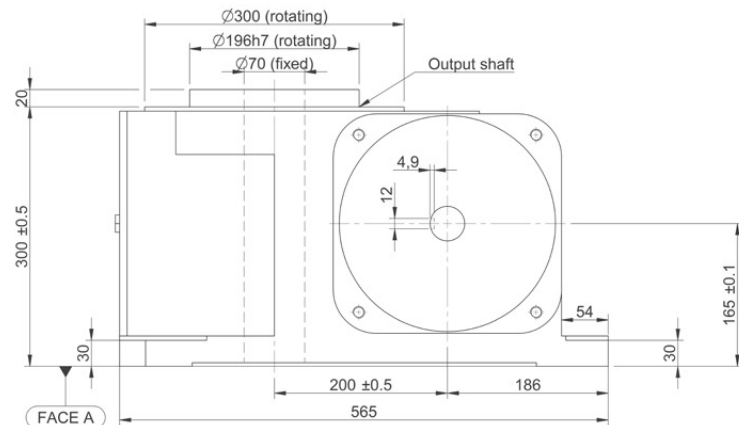

PIC 200	
Repeatability Répétabilité	$\pm 0,009$ mm on/sur $\varnothing 300$
Indexing accuracy Précision d'indexage	$\pm 0,017$ mm on/sur $\varnothing 300$
Maximum allowable axial load Charge axiale max. admissible	53.213 N
Maximum allowable tilting torque Couple de basculement max. admissible	2.570 Nm
Maximum allowable radial load Charge radiale max. admissible	10.000 N
Weight with moto reducer Poids de l'indexeur motorisé	~ 250 Kg

PIC 250

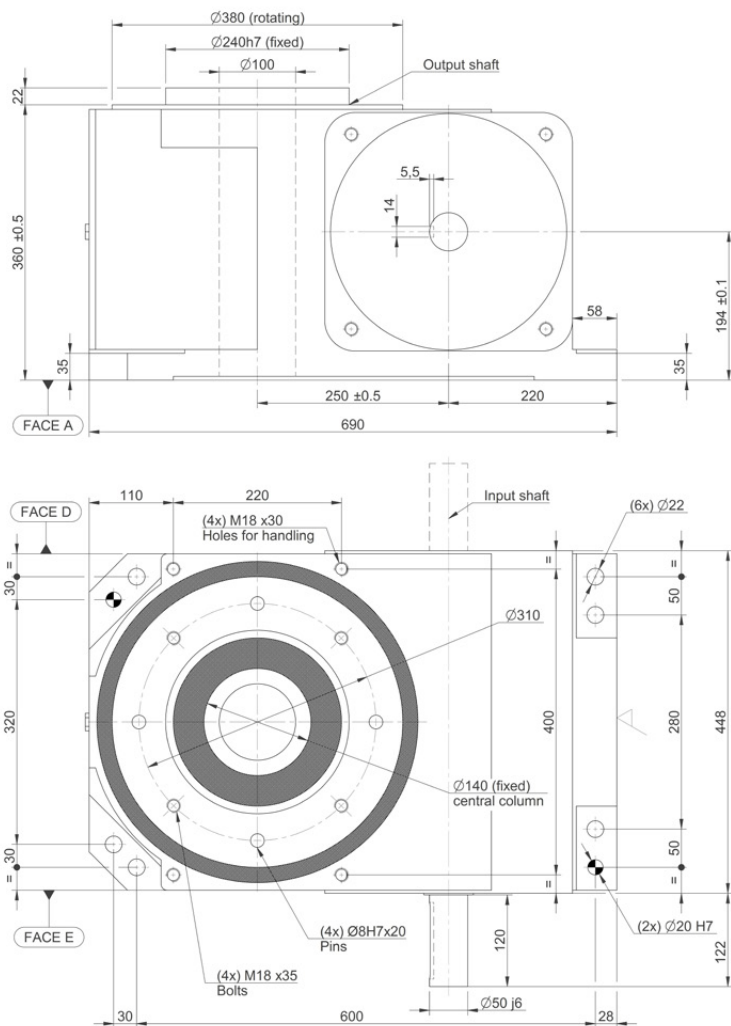

PIC 250	
Repeatability Répétabilité	$\pm 0,009$ mm on/sur $\varnothing 380$
Indexing accuracy Précision d'indexage	$\pm 0,017$ mm on/sur $\varnothing 380$
Maximum allowable axial load Charge axiale max. admissible	78.294 N
Maximum allowable tilting torque Couple de basculement max. admissible	4.665 Nm
Maximum allowable radial load Charge radiale max. admissible	15.000 N
Weight with moto reducer Poids de l'indexeur motorisé	~ 450 Kg

PIC 315

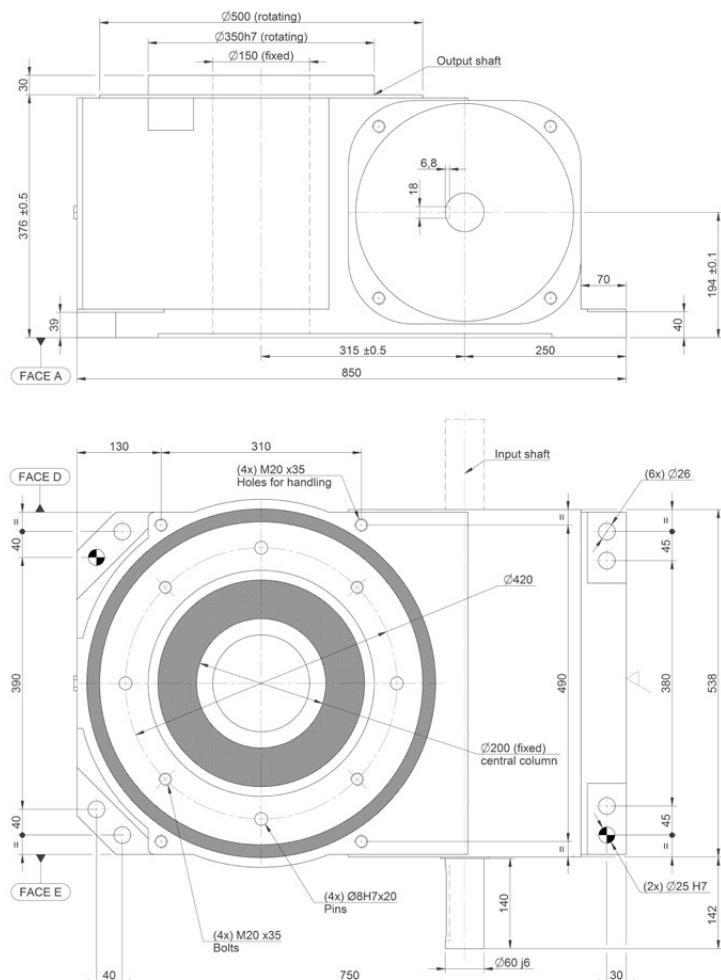

PIC 315	
Repeatability Répétabilité	$\pm 0,009$ mm on/sur $\varnothing 500$
Indexing accuracy Précision d'indexage	$\pm 0,017$ mm on/sur $\varnothing 500$
Maximum allowable axial load Charge axiale max. admissible	170.641 N
Maximum allowable tilting torque Couple de basculement max. admissible	6.768 Nm
Maximum allowable radial load Charge radiale max. admissible	18.000 N
Weight with moto reducer Poids de l'indexeur motorisé	~ 850 Kg

PIM 100

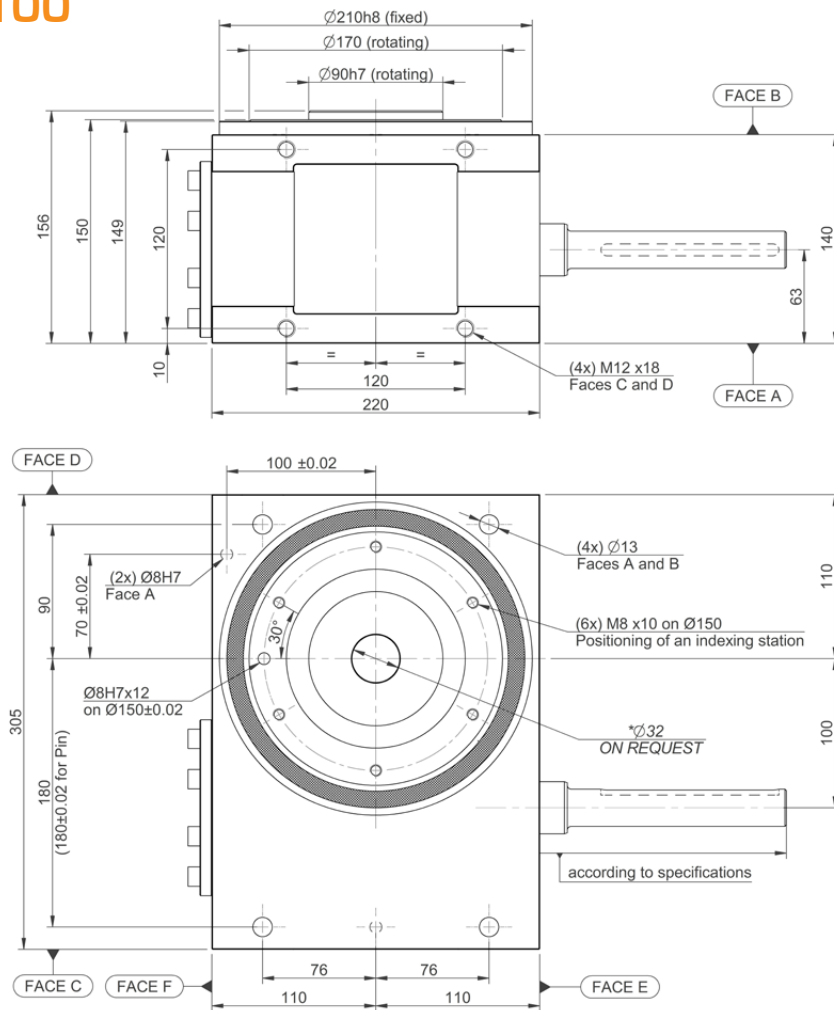

PIM 100

Repeatability Répétabilité	$\pm 0,011$ mm on/sur $\varnothing 170$
Indexing accuracy Précision d'indexage	$\pm 0,021$ mm on/sur $\varnothing 170$
Maximum allowable axial load Charge axiale max. admissible	11.000 N
Maximum allowable tilting torque Couple de basculement max. admissible	1.200 Nm
Maximum allowable radial load Charge radiale max. admissible	10.000 N
Weight with moto reducer Poids de l'indexeur motorisé	~ 65 Kg

PIM 175

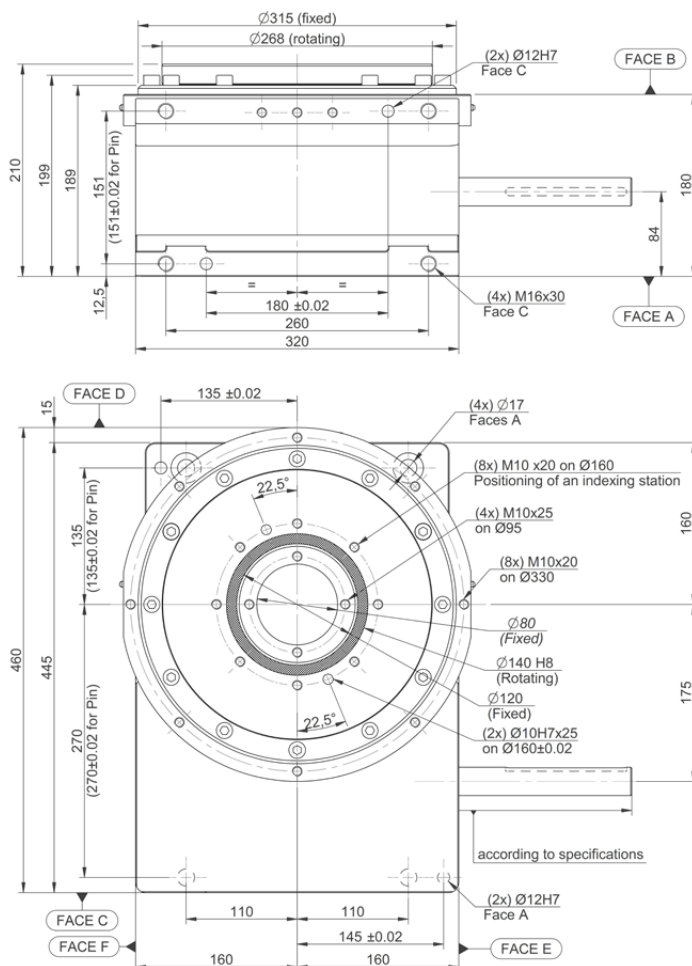

PIM 175

Repeatability Répétabilité	$\pm 0,008$ mm on/sur $\varnothing 268$
Indexing accuracy Précision d'indexage	$\pm 0,016$ mm on/sur $\varnothing 268$
Maximum allowable axial load Charge axiale max. admissible	31.000 N
Maximum allowable tilting torque Couple de basculement max. admissible	5.100 Nm
Maximum allowable radial load Charge radiale max. admissible	15.000 N
Weight with moto reducer Poids de l'indexeur motorisé	~ 125 Kg

GOIZPER

- GOIZPER GROUP

Antigua, 4
20577 Antzuola
Gipuzkoa - Spain

Tel: + 34 943 78 60 00
goizper@goizper.com

- GOIZPER FRANCE

Espace d'Activités Becquerel
15, Avenue Henri Becquerel
51000 Châlons en Champagne
France

Tel: + 33 (0)3 26 21 08 39
goizperfrance@goizper.com

- GOIZPER GmbH

Bevertalstr. 20
42499 Hückeswagen
Deutschland

Tel.: +49 (0) 2192 935 99 03
goizperdeutschland@goizper.com

- GOIZPER TRANSMISSION MACHINERY
(WUXI) CO., LTD.

No. 3 Workshop, Fengneng Road,
Wind Power Science & Technology
Industrial Park,
Huishan Economic Development Zone,
214174 Wuxi, Jiangsu - China

Tel: +86 186 217 020 36
goizperchina@goizper.com



Goizper Group
Growing through cooperation

www.goizper.com