

*Tri Power X33 TE*  
**10-60 kVA UPS**  
**Installation and Operation Manual**





# CONTENTS

<b>Preface</b> .....	1
<b>Safety</b> .....	2
<b>1. Function Description</b> .....	3
1-1. UPS Block Diagram.....	3
1-2. UPS Outlook View .....	4
<b>2. Installation and Wiring</b> .....	15
2-1. Storage and Installation Environment .....	15
2-2. Unpacking, Removing and Fixing UPS.....	16
2-3. General Requirement for Ventilation and Maintenance.....	23
2-4. Power Cables Connections .....	24
2-5. Communication Cables Connections.....	33
2-6. UPS Parallel Connections.....	37
<b>3. Operation Description</b> .....	42
3-1. Operation Modes.....	42
3-2. Online Operations .....	43
3-3. Manual Bypass Operation.....	43
3-4. Operation Processes .....	44
<b>4. Control Panel Operation and Function Description</b> .....	45
4-1. Screen Introduction.....	45
4-2. Menu .....	46
4-3. Mimic Display .....	49



<b>5. Options</b> .....	50
5-1. Dry Contact Card .....	50
5-2. RS-485 MODBUS Card .....	50
5-3. SNMP Card.....	50
5-4. Temperature Sensor .....	50
5-5. DC Cold Start Kit.....	51
5-6. Parallel Communication Cable .....	51
<b>6. Troubleshooting</b> .....	52
<b>7. Technical Specification</b> .....	53



## **Preface**

We thank you for the trust in selecting our UPS.

Our equipment complies with the European Community directives for professional equipment and is authorized to use the CE marking.



The purpose of this manual is to introduce the operating principles of the UPS and to provide instructions for its safe operation. The manual also provides troubleshooting assistance should an abnormal message or behavior occur.

Should an abnormal message not covered in this manual appear, please contact your local authorized service agent for troubleshooting and repair.

All of the installation, operation, and maintenance of this device must be performed by authorized and qualified technicians who are familiar with this manual.



## Safety

### ● Important Rules

- (1) Please follow these UPS operating instructions to ensure safe and proper operation.
- (2) When the UPS is being moved or operated, please ensure that the machine is standing vertically. Do not shake or tip over the machine. Avoid heavy impact.
- (3) Poor grounding will lead to unexpected current leakage. Please ensure that the AC power input is properly grounded (PE Ground) before making any connections.
- (4) Please make sure that the UPS is placed in an insulated environment before use and that there is no electrocution hazard to the operating personnel.
- (5) Do not connect the neutral wire with the ground and make sure that the input voltage is correct.
- (6) Once the UPS has been switched on, if the UPS needs to be moved then it must be fully switched off and fully discharged. If the UPS is not discharged, the UPS will switch to battery power after grid power is disconnected and pose an electrocution hazard.
- (7) Do not place any objects, liquid containers, or coverings over the UPS. The liquid spilt into the UPS or heat prevented from dissipating could lead to internal damage or cause electrocution.
- (8) Make sure that the battery specifications match the UPS requirements before connecting any external batteries.
- (9) Please follow the rules below before engaging in any activity that involves the battery.
  - a. Remove all metallic items such as rings, watches and jewelry before working on the battery.
  - b. Please use insulated tools.
  - c. Do not open or damage the battery. The toxic liquid inside will harm the skin and eyes.
  - d. Keep batteries away from fire to prevent explosion.

### ● Symbols

Please follow the instructions and warnings on the UPS.



WARNING ! Refer to the operating instructions.



WARNING ! High voltage inside.



WARNING ! Refer to the operating instructions.

WARNING ! High voltage inside.

Ground

# 1. Function Description

## 1-1 UPS Block Diagram

This UPS provides Mains input and Bypass input for dual inputs application. The system block diagram as shown below.

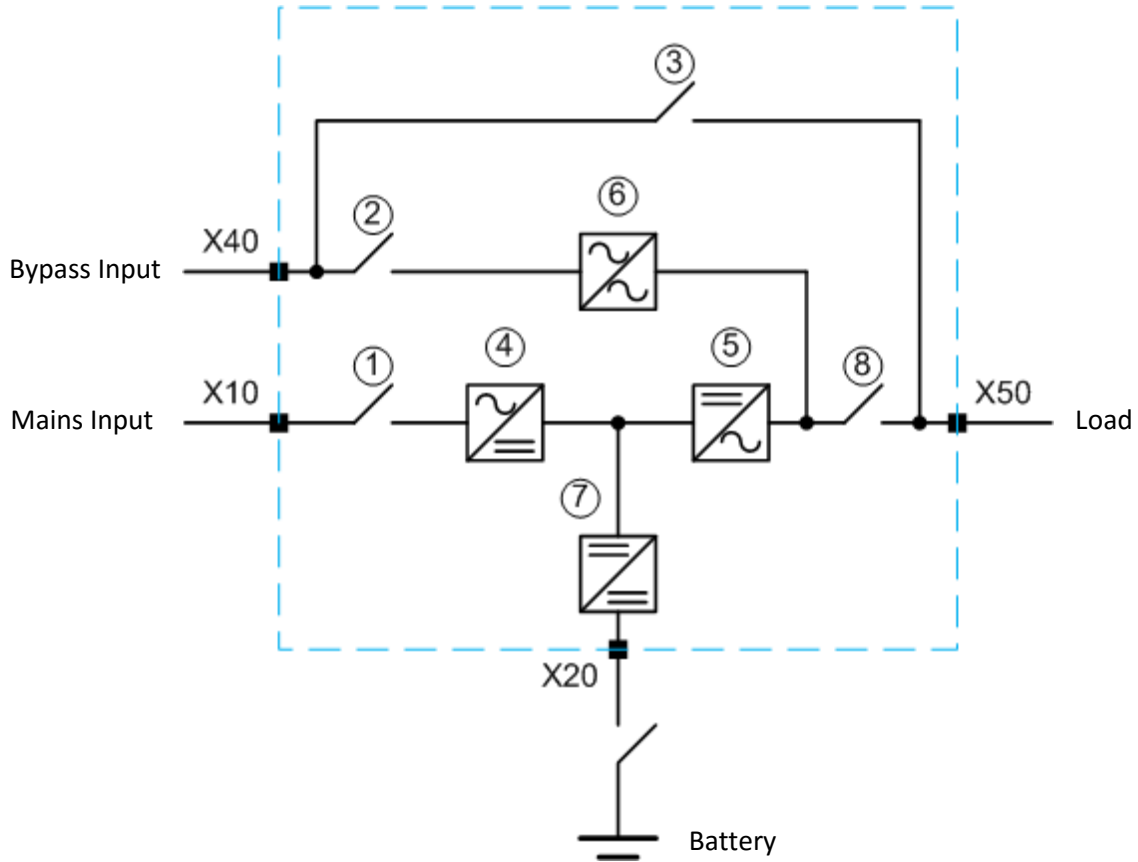

- |                         |                    |
|-------------------------|--------------------|
| 1. Input Switch         | 5. Inverter        |
| 2. Bypass Switch        | 6. Static Switch   |
| 3. Manual Bypass Switch | 7. Charger/Booster |
| 4. Rectifier            | 8. Output Switch   |

## 1-2 UPS Outlook View

### ■ 10-40kVA Front View

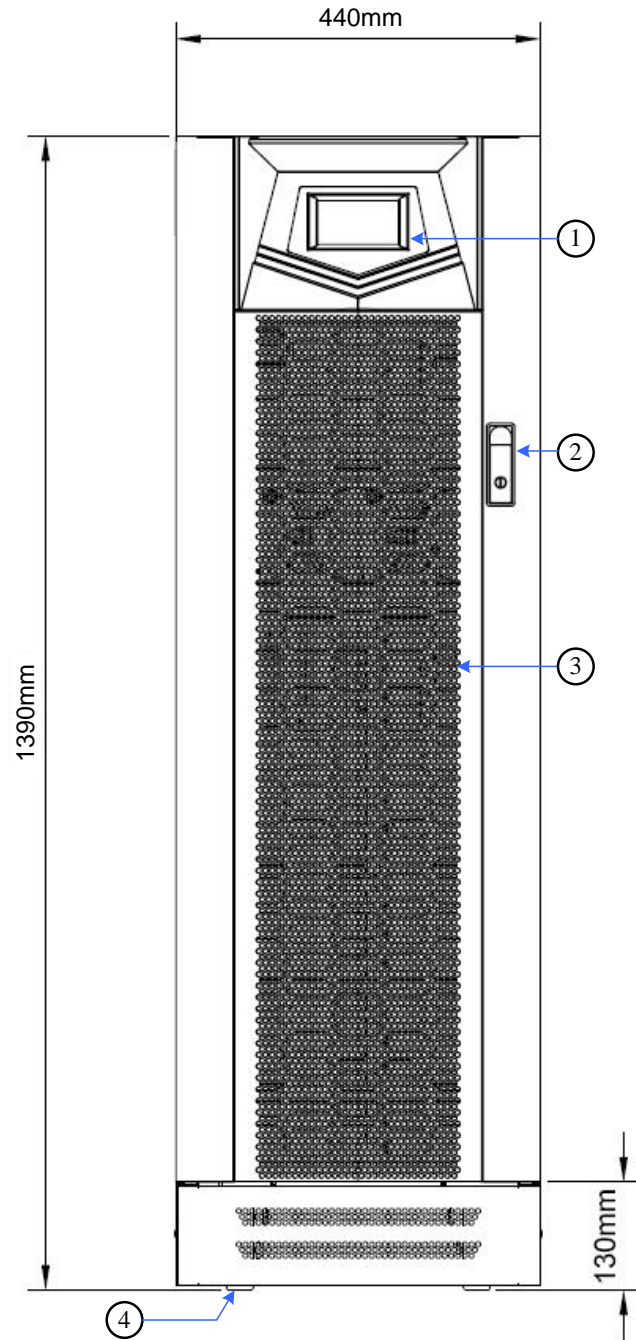

- |   |                        |
|---|------------------------|
| 1. Control Panel with Colorful LCD Touch Screen | 3. Ventilation Grille  |
| 2. Handle with Lock                             | 4. Wheels for Handling |

■ **10-20kVA Right Side View**

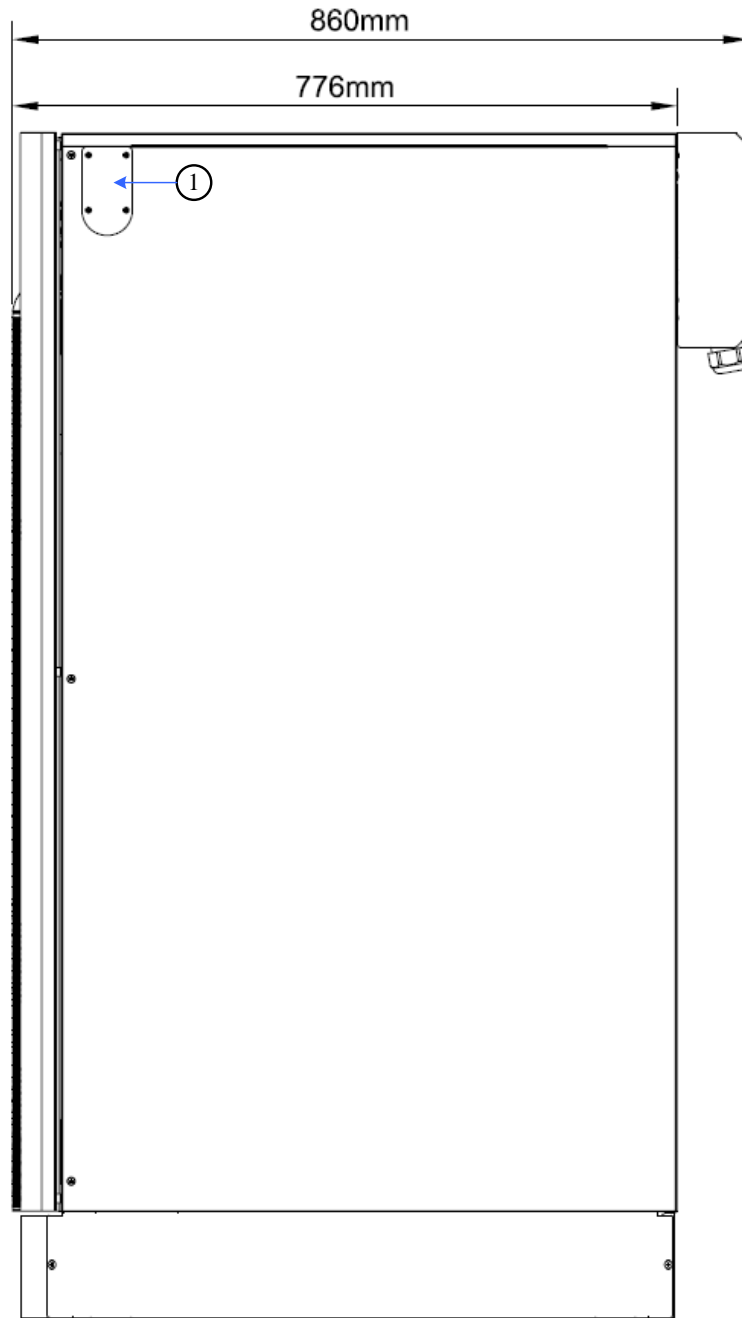

1. Through Hole for Parallel Communication Cable



■ 10-20kVA Internal View

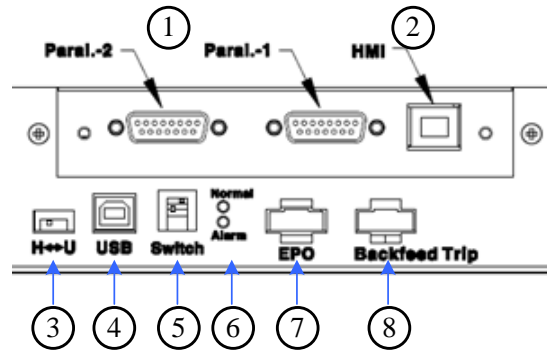
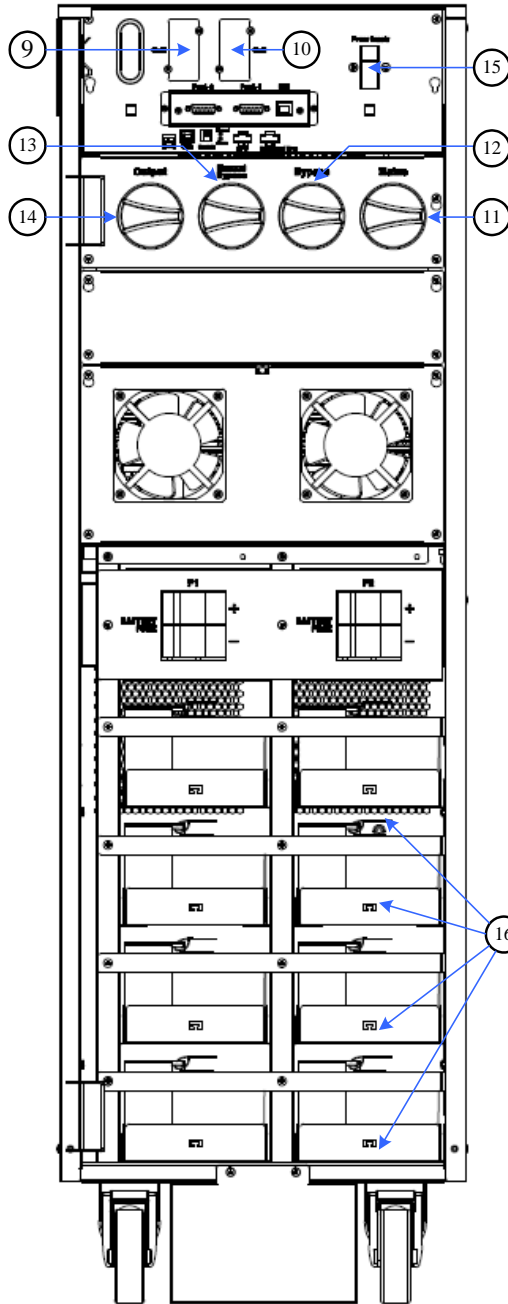

1. Parallel Communication Ports
2. HMI Communication Port
3. Communication Selector for Service only
4. USB Port for Service Only
5. Terminal Resistor Setting Switch for Parallel Communication
6. Status LED Indicators
7. EPO
8. Backfeed Protection
9. Communication Card Slot2
10. Communication Card Slot1

Please find the detail descriptions of above items on section 2-5.

11. Mains Input Switch
12. Bypass Input Switch
13. Manual Bypass Switch

14. Output Switch
15. Fuse for Control Power
16. Battery Tray

■ **10-20kVA Rear View**

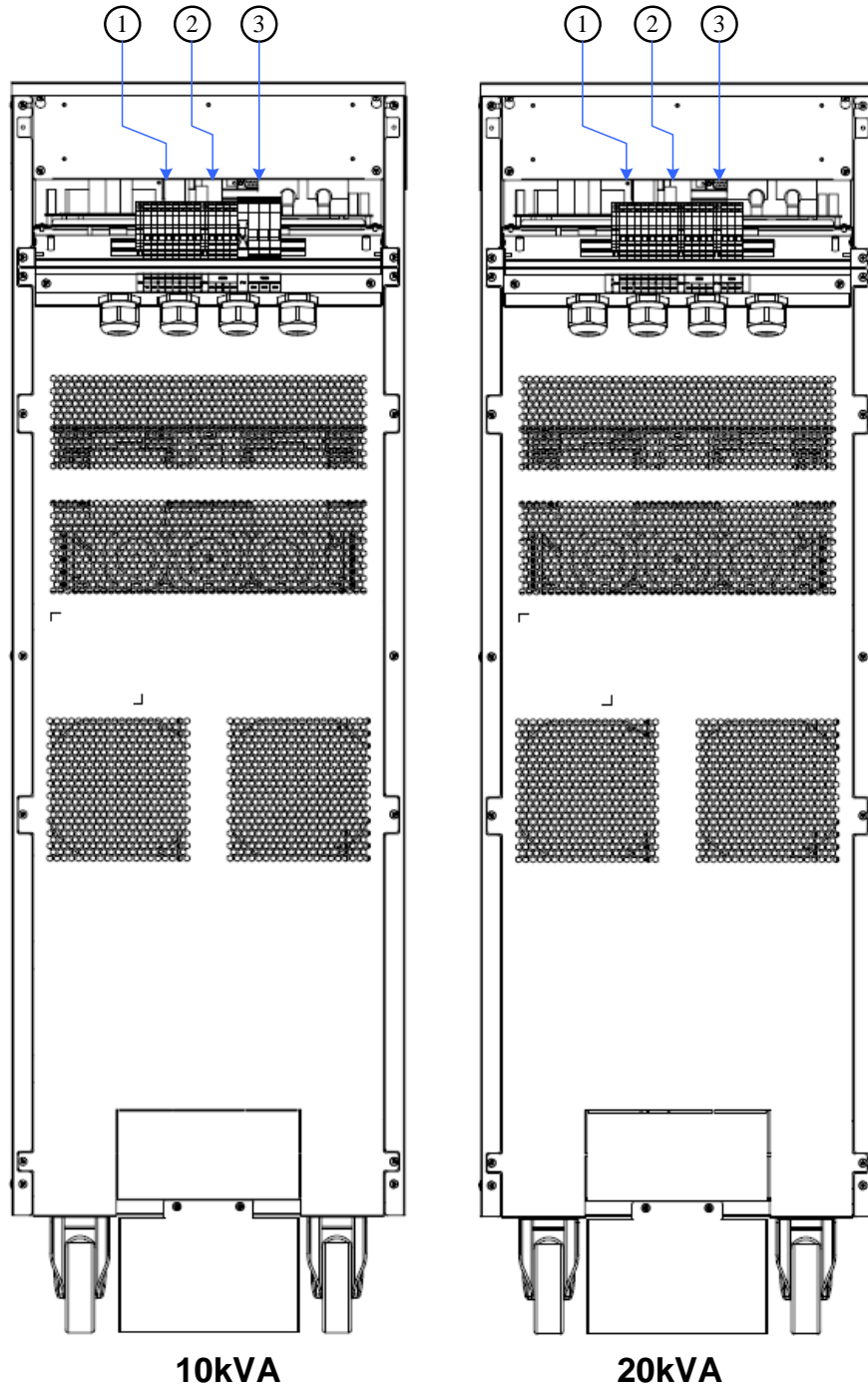

- 1. X10/ X40: Mains/ Bypass Input Connections Terminal (1N, 2N, 1L3, 2L3, 1L2, 2L2, 1L1, 2L1)

- 2. X50: Output Connections Terminal (3N, 3L3, 3L2, 3L1)
- 3. X20: External Battery Connections Terminal (B+, N, B-)

■ **30-40kVA Right Side View**

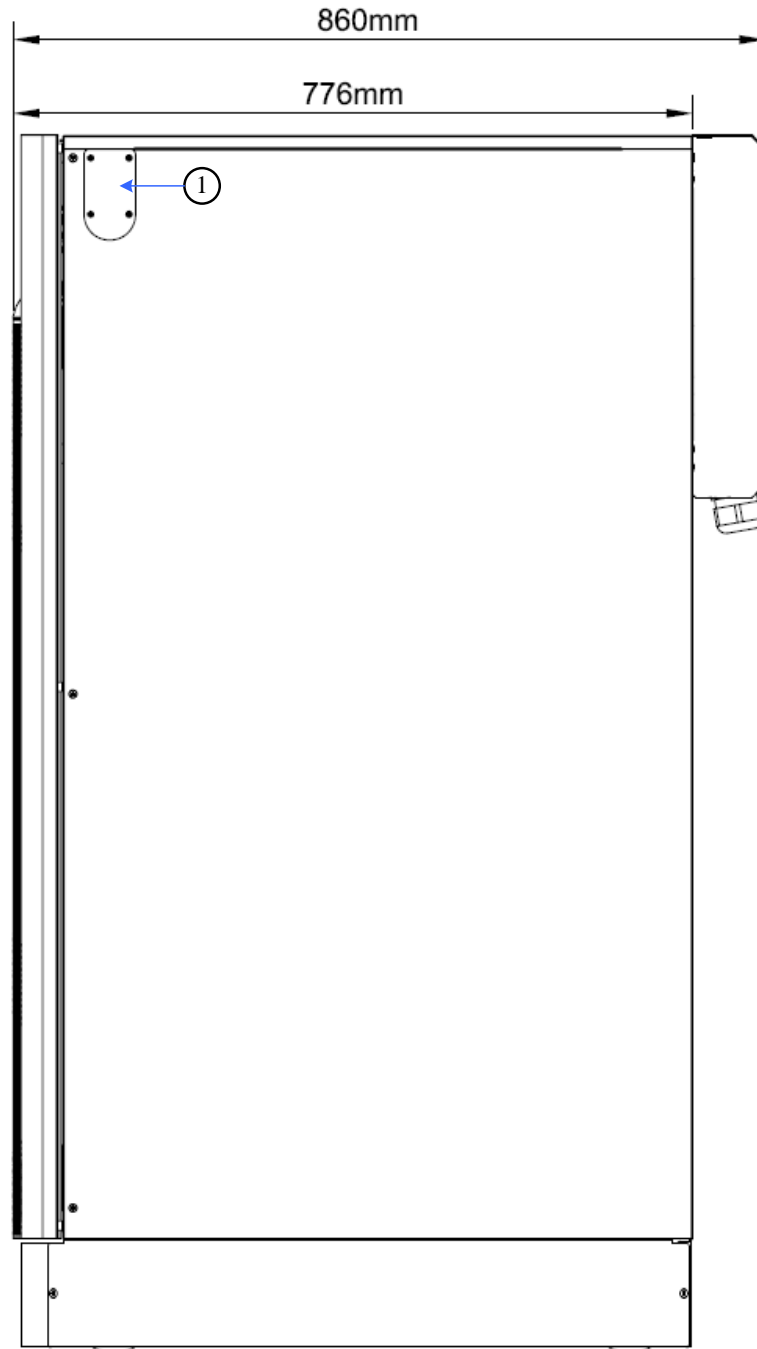

1. Through Hole for Parallel Communication Cable

■ 30-40kVA Interval View

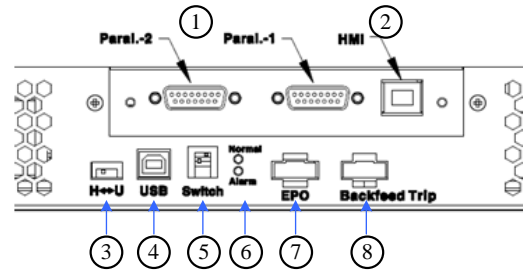
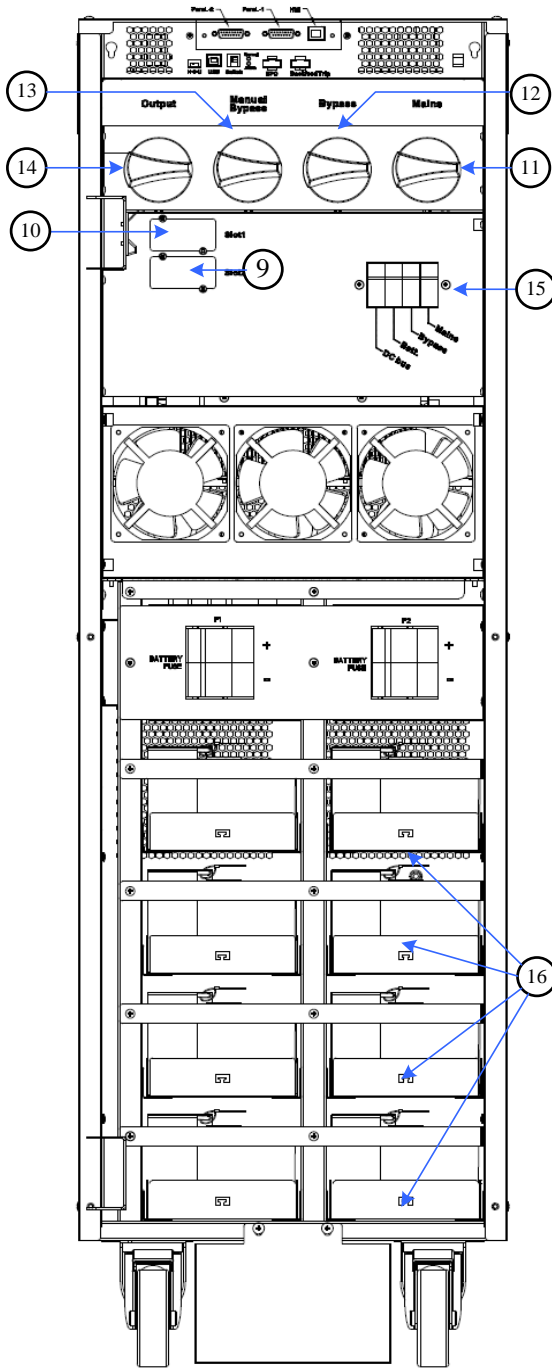

1. Parallel Communication Ports
2. HMI Communication Port
3. Communication Selector for Service Only
4. USB Port for Service Only
5. Terminal Resistor Setting Switch for Parallel Communication
6. Status LED Indicators
7. EPO
8. Backfeed Protection
9. Communication Card Slot2
10. Communication Card Slot1

Please find the detail descriptions of above items on section 2-5.

11. Mains Input Switch
12. Bypass Input Switch
13. Manual Bypass Switch

14. Output Switch
15. Fuses for Control Power
16. Battery Tray

■ 30-40kVA Rear View

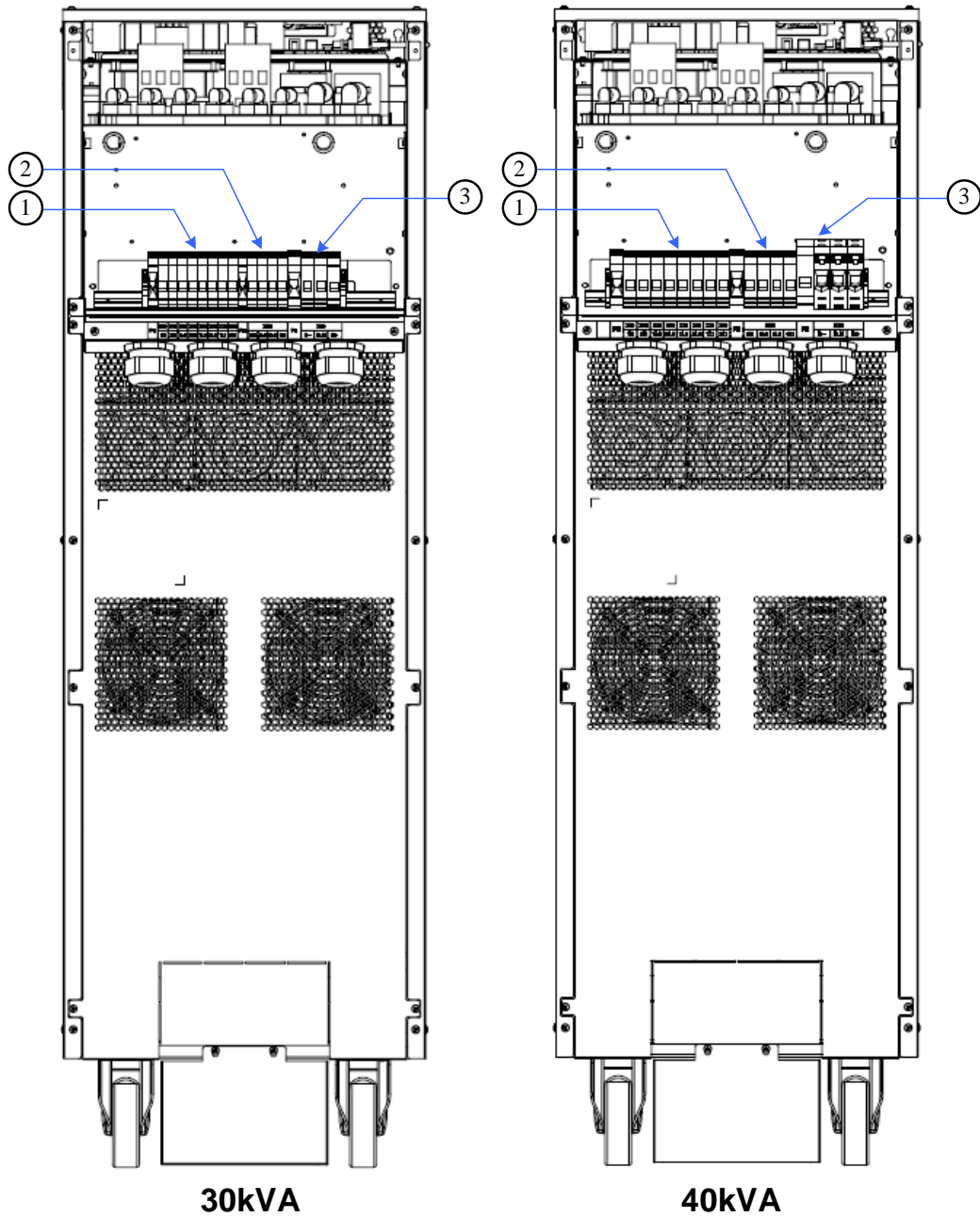

1. X10/ X40: Mains/ Bypass Input Connections Terminal (1N, 2N, 1L3, 2L3, 1L2, 2L2, 1L1, 2L1)

2. X50: Output Connections Terminal (3N, 3L3, 3L2, 3L1)  
 3. X20: External Battery Connections Terminal (B+, N, B-)

■ 60kVA Front View

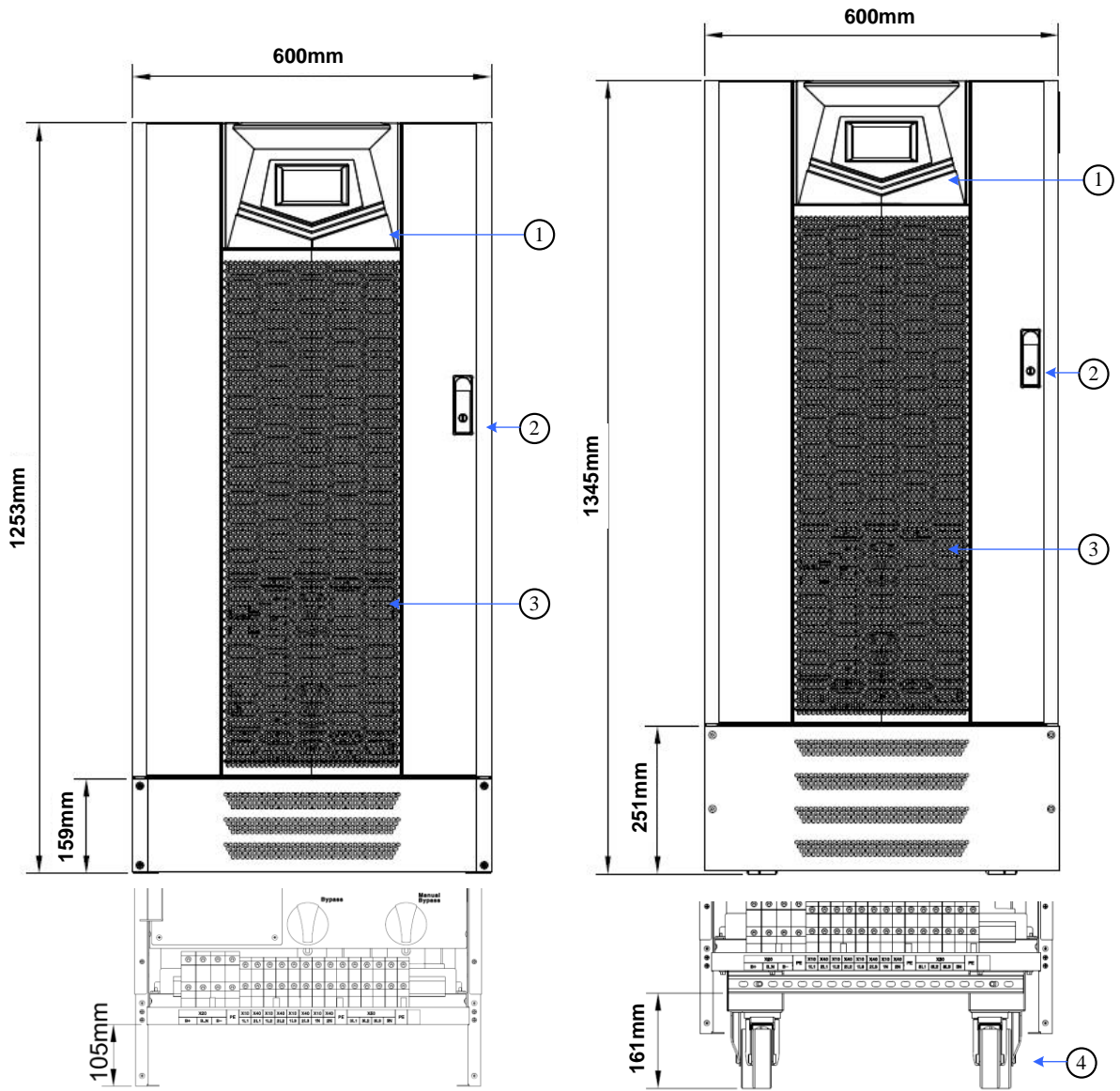

**Stationary Type  
(Without Wheel)**

**Wheel Type**

- |   |                        |
|---|------------------------|
| 1. Control Panel with Colorful LCD Touch Screen | 3. Ventilation Grille  |
| 2. Handle with Lock                             | 4. Wheels for Handling |

■ **60kVA Left Side View**

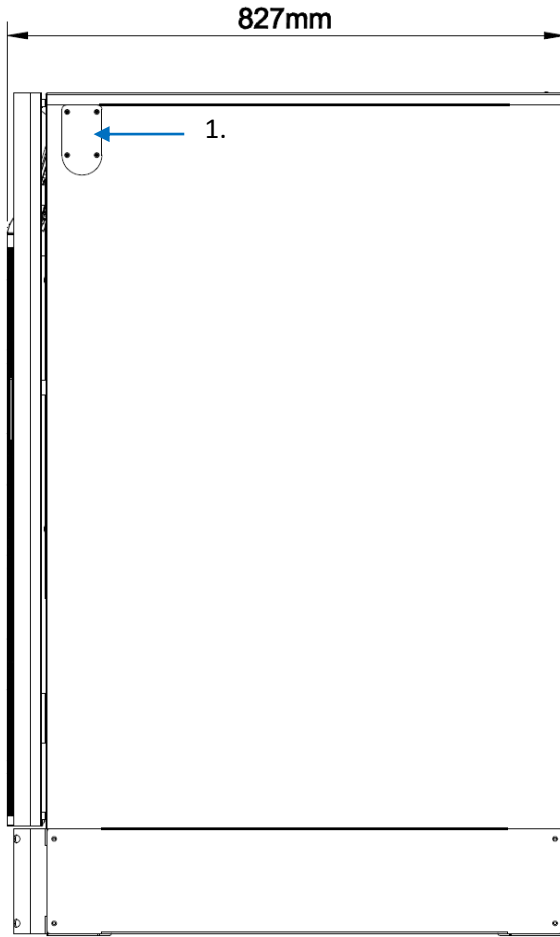

**Stationary Type  
(Without Wheel)**

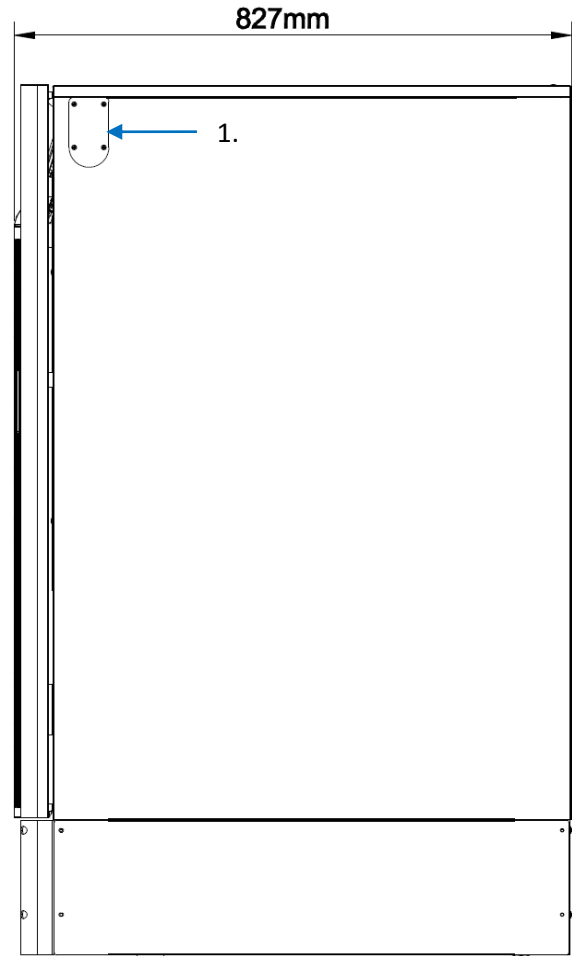

**Wheel Type**

- 1. Through Hole for Parallel Communication Cable

■ 60kVA Internal View

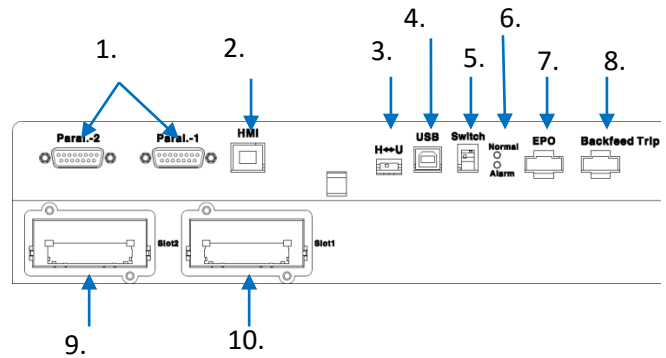
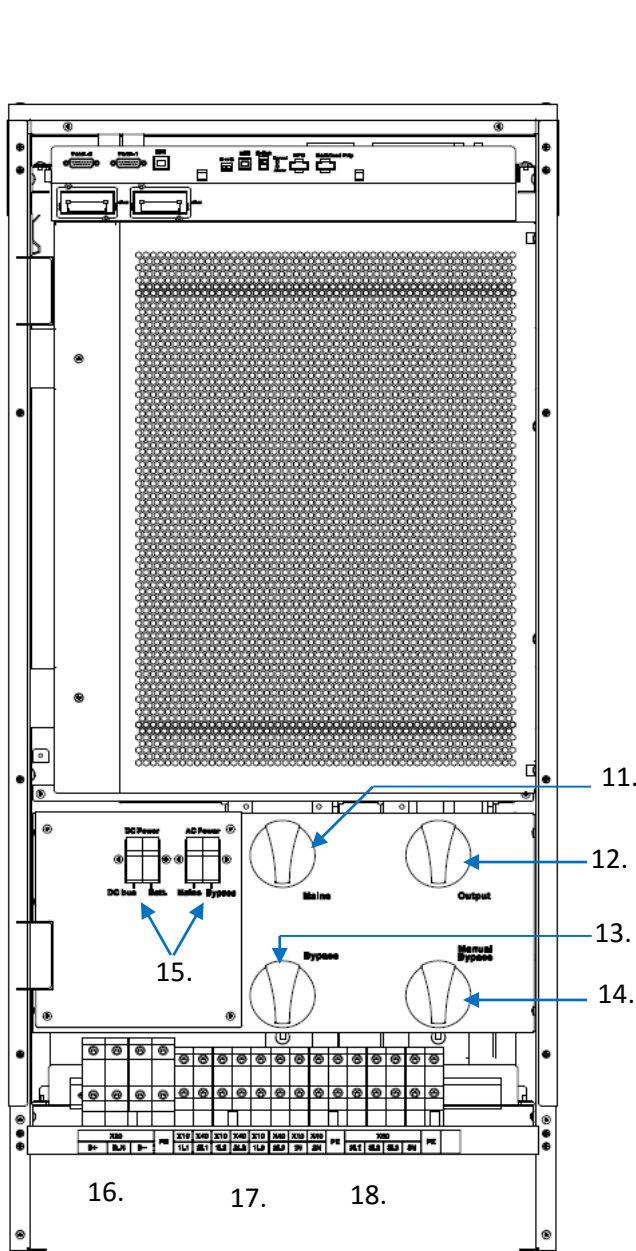

1. Parallel Communication Ports
2. HMI Communication Port
3. Communication Selector for Service Only
4. USB Port for Service Only
5. Terminal Resistor Setting Switch for Parallel Communication
6. Status LED Indicators
7. EPO
8. Backfeed Protection
9. Communication Card Slot2
10. Communication Card Slot1

Please find the detail descriptions of above items on section 2-5.

- |   |  |
|---|--|
| <ol style="list-style-type: none"> <li>11. Mains Input Switch</li> <li>12. Output Switch</li> <li>13. Bypass Input Switch</li> <li>14. Manual Bypass Switch</li> <li>15. Fuses for Control Power</li> </ol> | <ol style="list-style-type: none"> <li>16. X20: External Battery Connection Terminals (B+, N, B-, G)</li> <li>17. X10/ X40: Mains/ Bypass Input Connections Terminal (1N, 2N, 1L3, 2L3, 1L2, 2L2, 1L1, 2L1)</li> <li>18. X50: Output Connection Terminals (3N, 3L3, 3L2, 3L1)</li> </ol> |
|---|--|



### ■ Rear Side of Front Door View

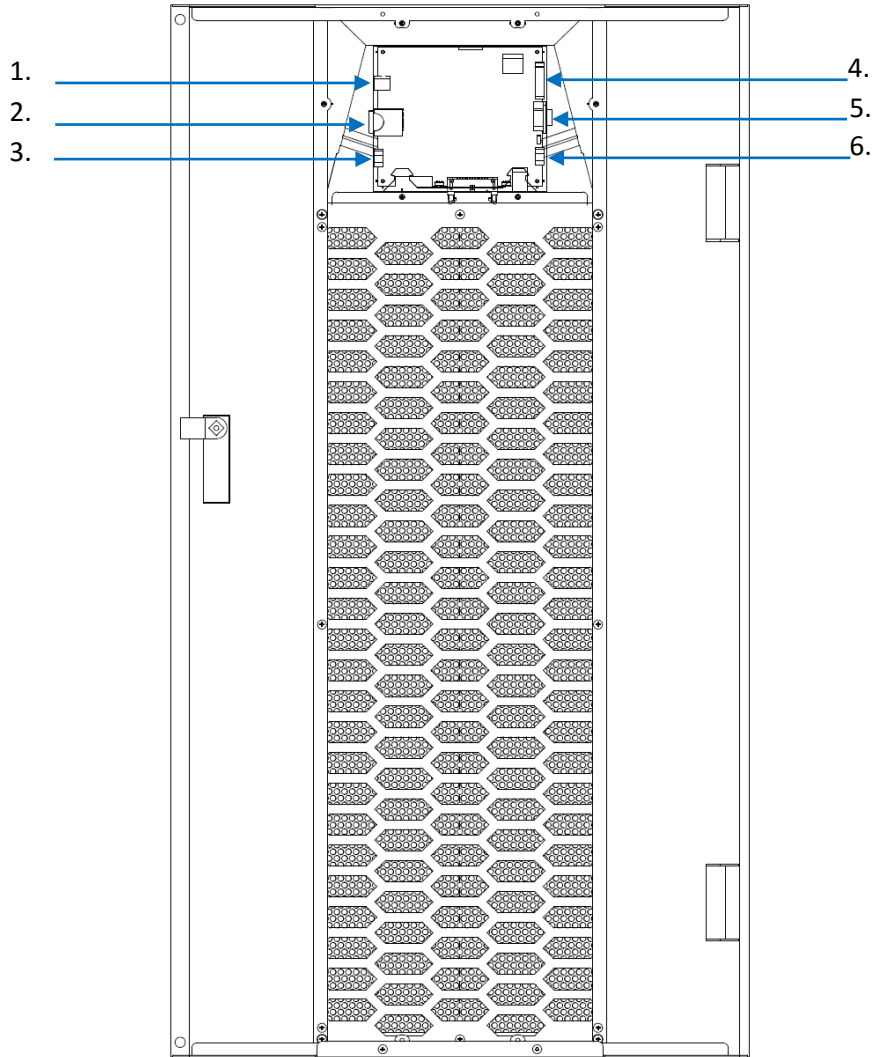

- |   |  |
|---|--|
| 1. USB Port for Setting Software          | 4. Output & Input Contacts             |
| 2. SD Card Slot                           | 5. RS-232 Port for Setting Software    |
| 3. External Battery Temperature Connector | 6. Communication Port for Remote Panel |

Please find the detail descriptions of above items on section 2-5.



## 2. Installation and Wiring

### 2-1 Storage and Installation Environment

#### ■ Storage Environment

- Temperature  $-20^{\circ}\text{C}\sim 70^{\circ}\text{C}$
- Relative Humidity  $\leq 95\%$

#### ■ Installation Environment

A proper installation environment not only ensures the effective operation of the UPS but also reduces the chance of failure and extends service life. Please take the following recommendations into account to select the most suitable environment and reduce the likelihood of accidents.

- Temperature  $0^{\circ}\text{C}\sim 40^{\circ}\text{C}$  ( $20^{\circ}\text{C}\sim 25^{\circ}\text{C}$  is recommended for extend batteries life time).
- Relative Humidity  $\leq 95\%$  (without condensation)
- Altitude 1000m at normal power. Over 1000m above sea level, the maximum output current must be derated by 1% every additional 100m.
- This product must not be used in an environment with sparks, smoke or gas to prevent arcing, injury and fire hazards.
- Avoid using dusty materials, volatile gases, or corrosive substances with a high salt-content in the environment where the UPS is installed.
- The installation location of the UPS should be well-ventilated. During charging, the chemical reaction of the battery generates small amounts of gases. If there is a crack in the battery then this may pose an environmental hazard.
- Do not place in a location near a heat source as this will shorten the battery life.
- Do not place outdoors and avoid direct exposure to sunlight.
- Please ensure that the environment where the UPS is placed is free from animals that may damage the wiring, such as: rats and other small animals.
- Please ensure that the floor is strong enough to hold the UPS and battery. It must keep the equipment stable to ensure that it won't suffer damage in a fall.
- We recommend placing a fire extinguisher near the UPS in case of an emergency.

## 2-2 Unpacking, Removing and Fixing UPS

This section describes the unpacking and removing processes for wheel type.

- Remove the packing materials and cut straps. Remove the cardboard box.

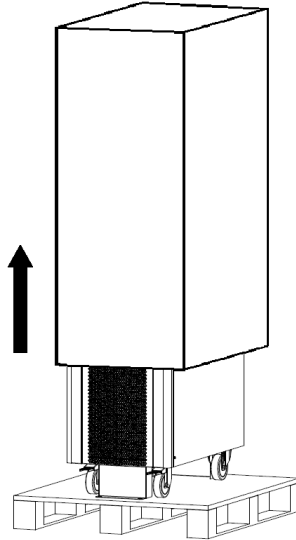

**10-40kVA**

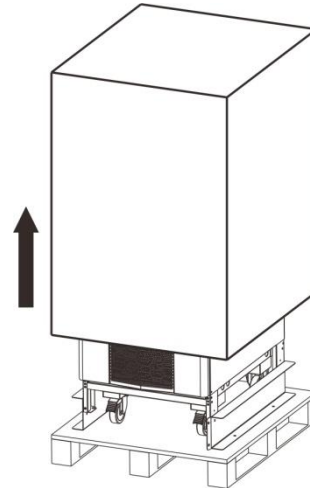

**60kVA**

- Unscrew the fastening rail kits on the front and rear side of 10-40kVA, and right and left side of 60kVA.

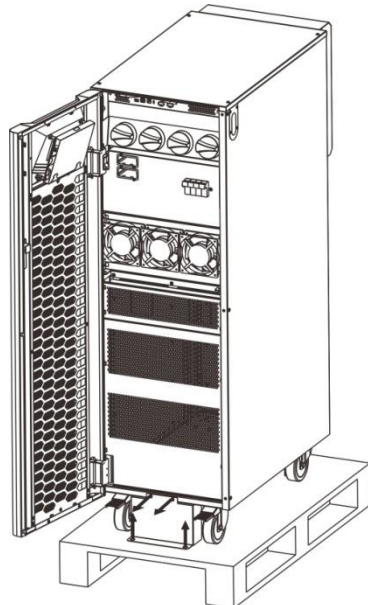

**10-40kVA**

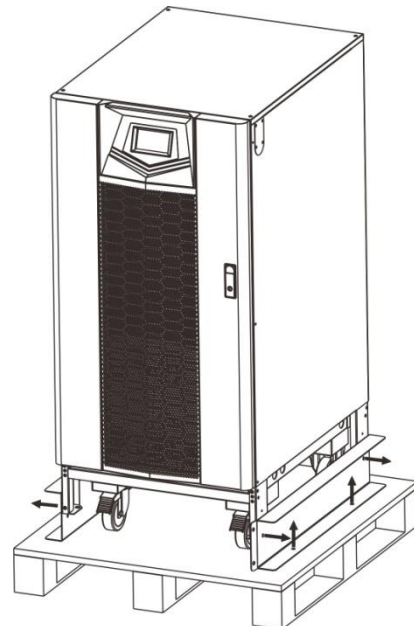

**60kVA**

- Put 2 fastening rail kits on the pallet edge and make them steady by fastening 4 screws in the pallet.

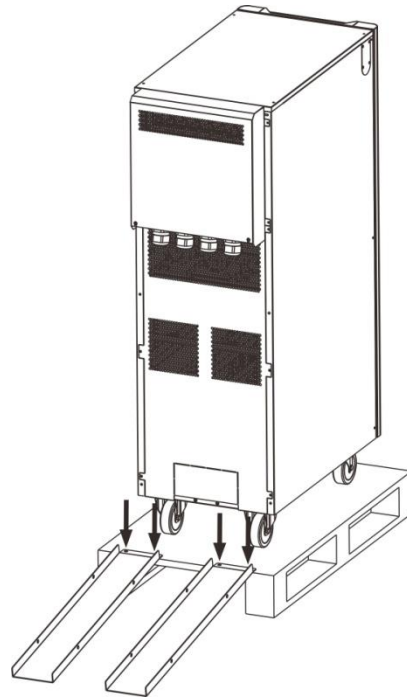

**10-40kVA**

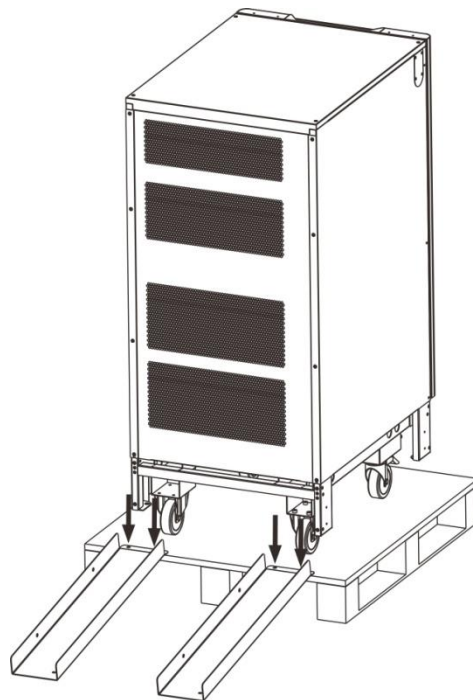

**60kVA**

- Raise 2 wheel-brakes or expansion feet for remove the UPS from the pallet.

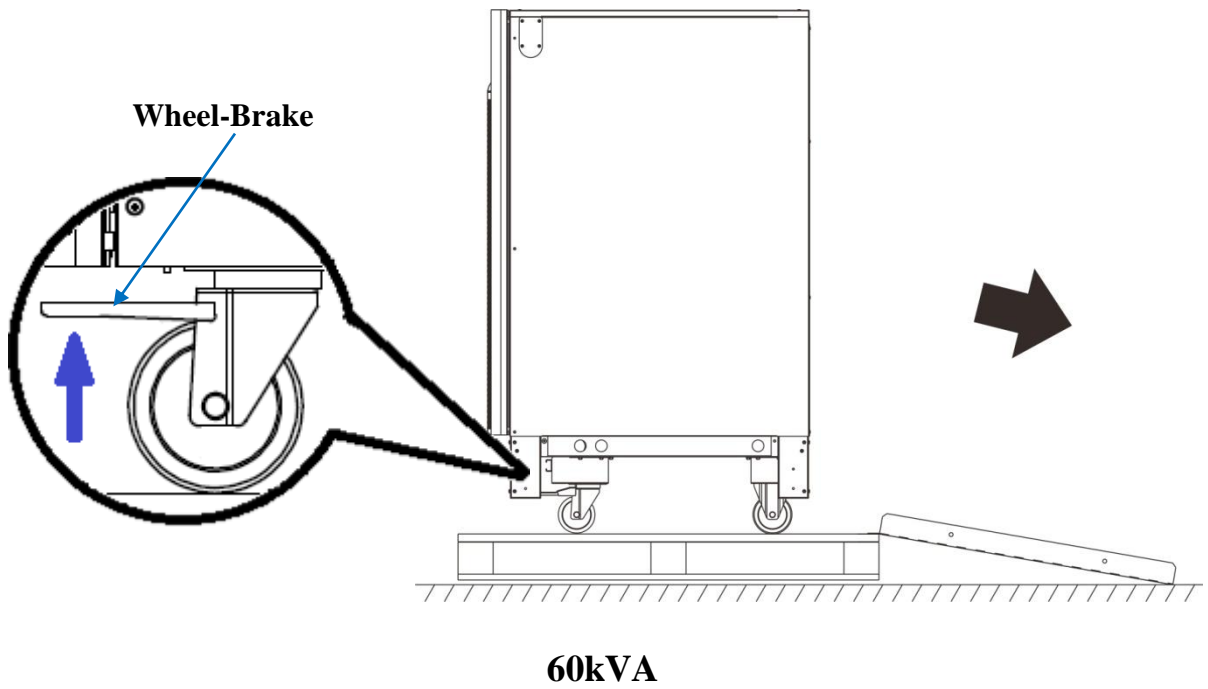
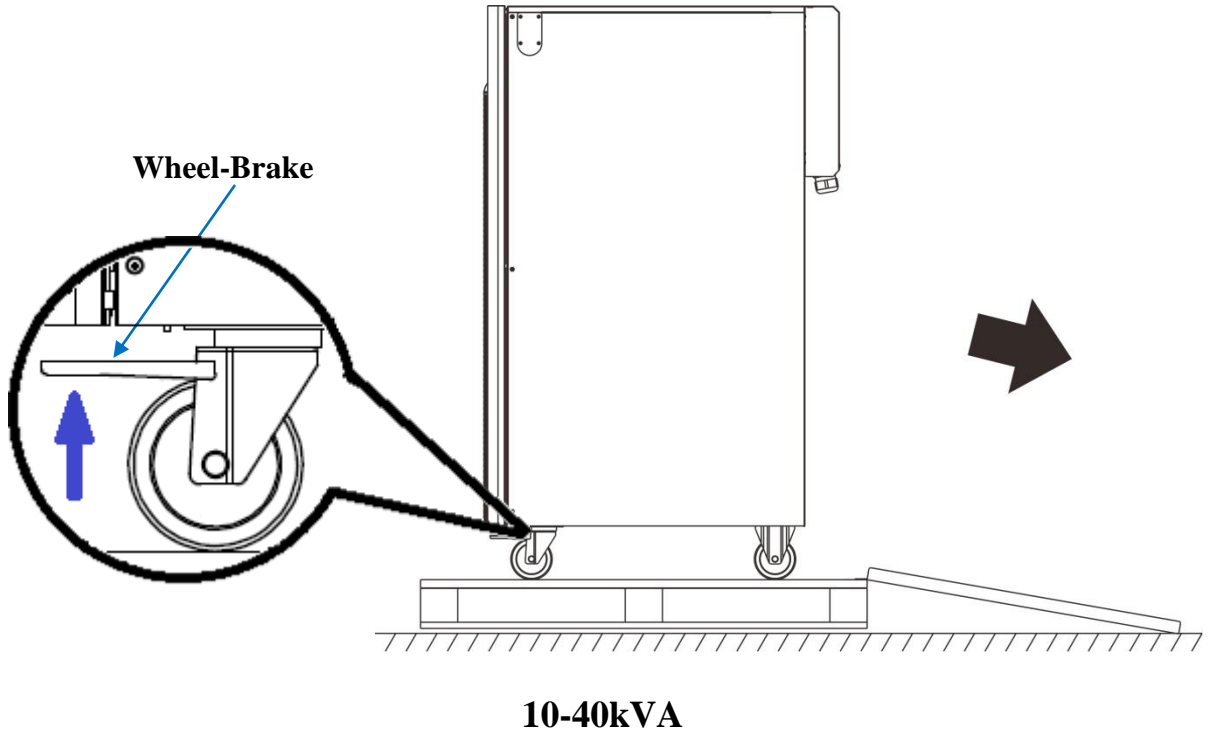

- Block 2 wheel-brakes or adjust the expansion foots to fix the UPS.

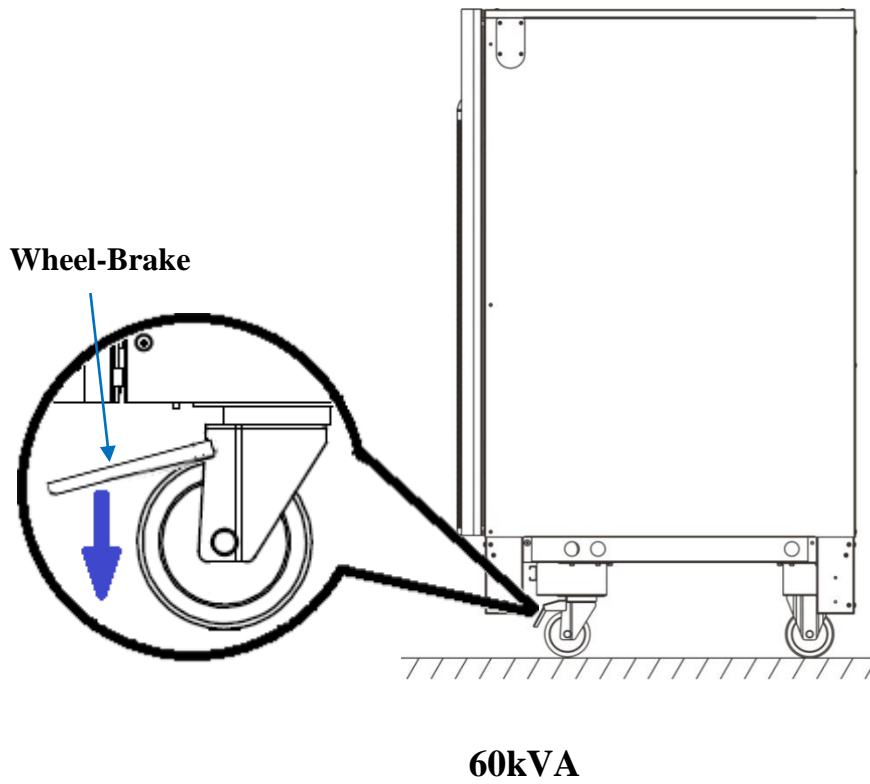
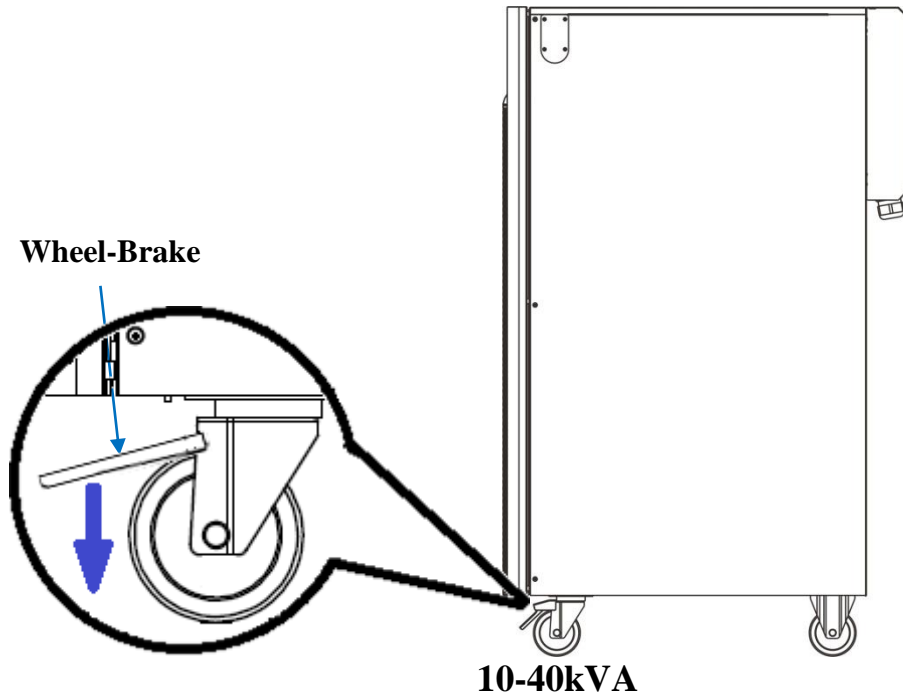

■ Floor Fixing for 10-40kVA

It is possible to reuse the fastening rail kits to fix the UPS to the floor.

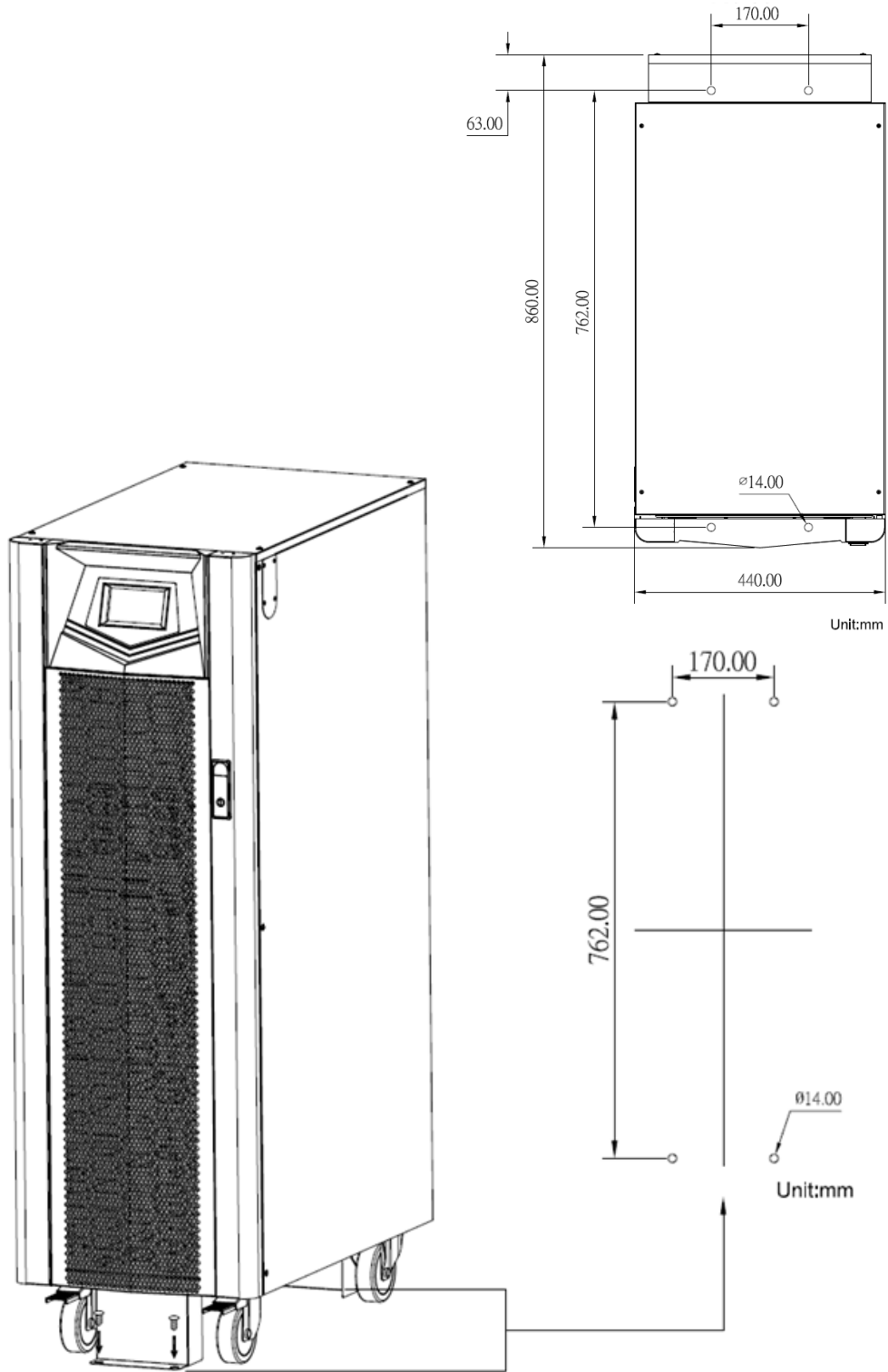

■ Floor Fixing for 60kVA Stationary Type(Without Wheel)

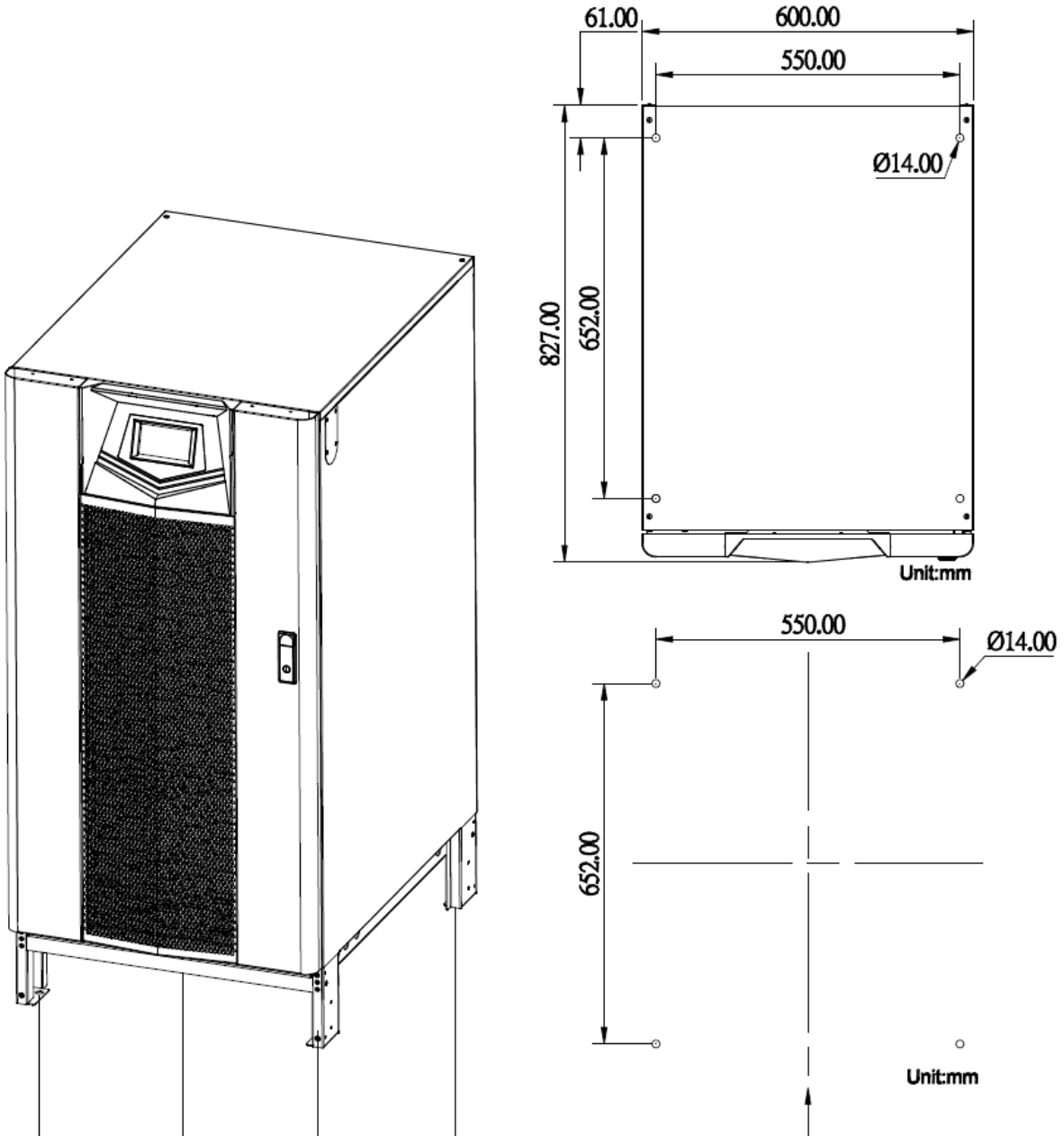



■ Floor Fixing for 60kVA Wheel Type

It is possible to reuse the fastening rail kits to fix the UPS to the floor.

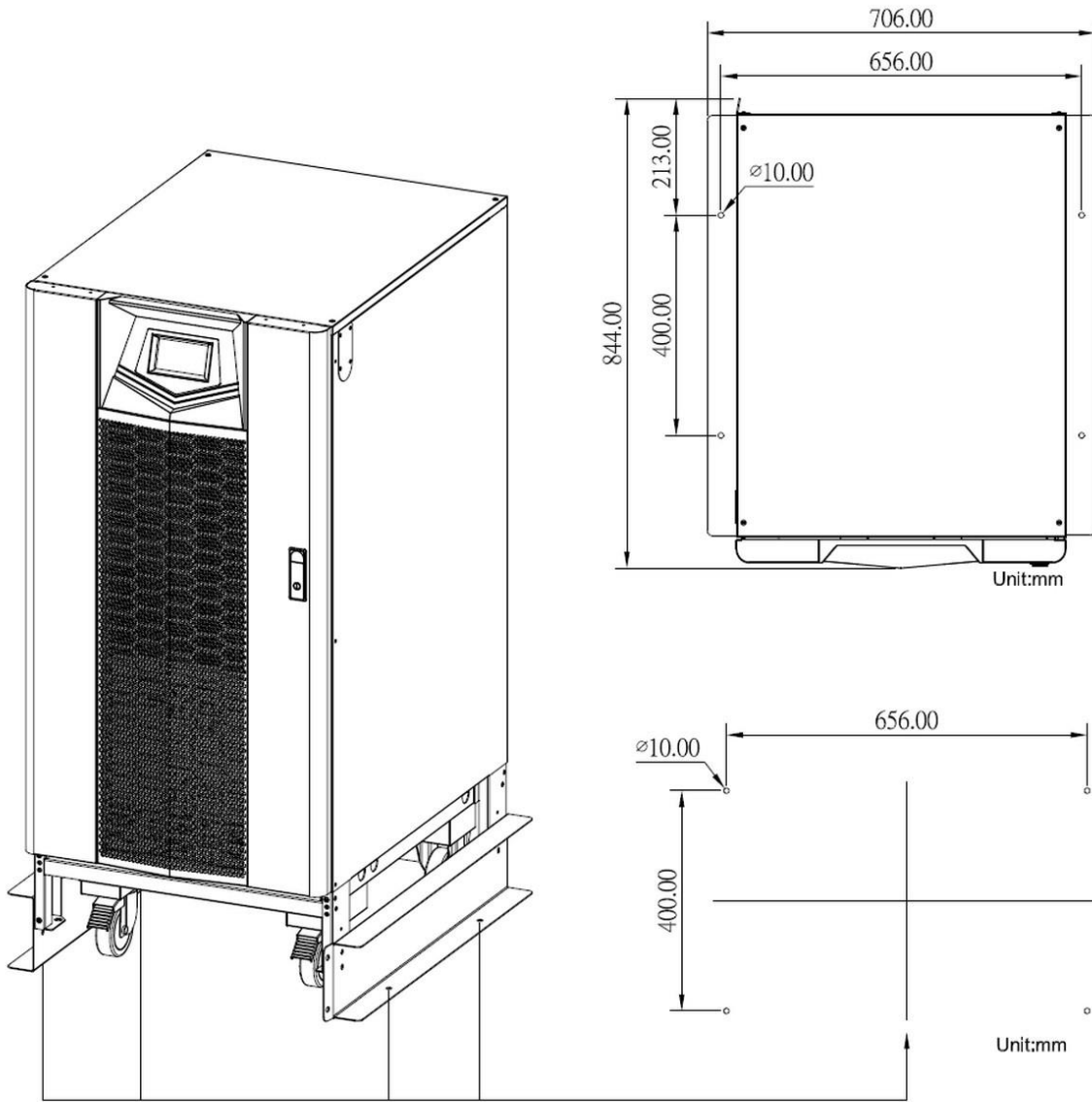

### 2-3 General Requirement for Ventilation and Maintenance

During installation ensure that the following conditions are met.

- Keep at least 1000 mm of free space in front of the UPS for air flow and future maintenance purposes.
- Keep at least 300mm of free space in rear of the UPS for air-flow space.
- Keep at least 500mm of free space in the top of UPS for maintenance operations.

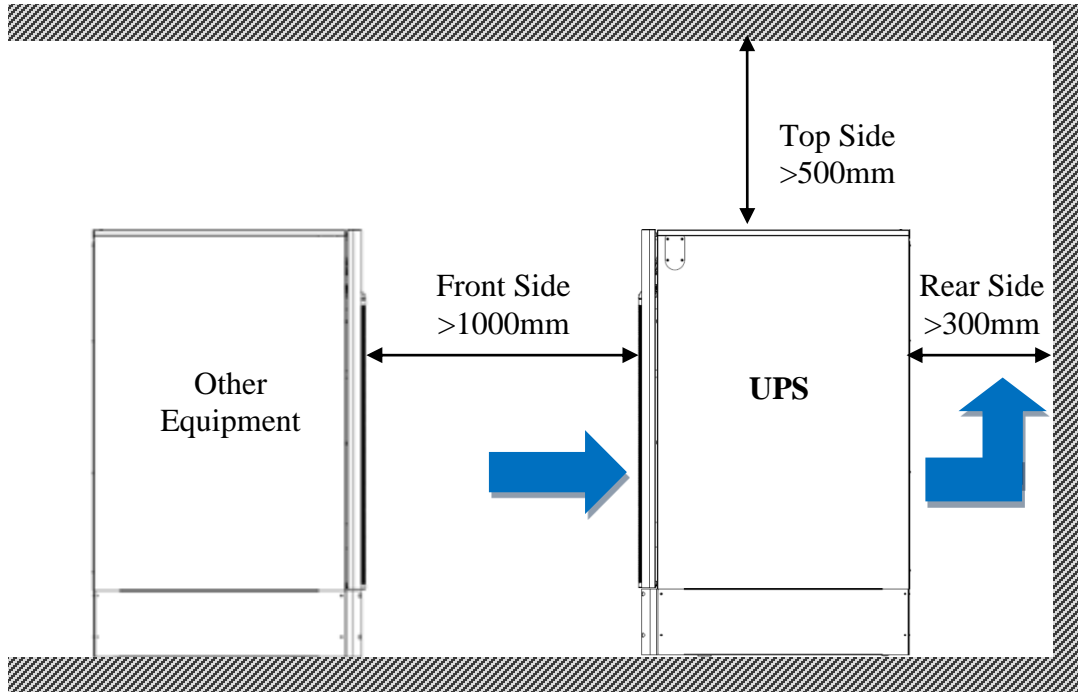

## 2-4 Power Cables Connections

### ■ Power Cable Sizing

The drawing below shows the positions of power terminals.

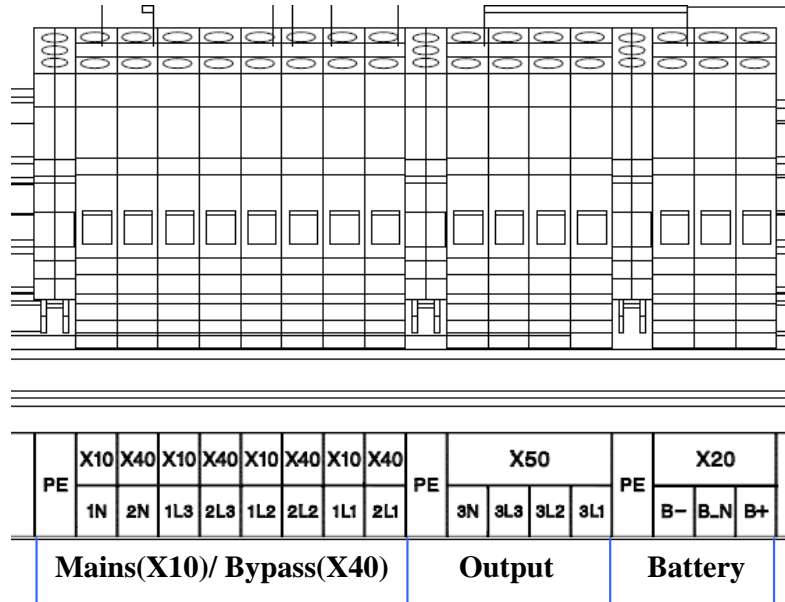

**10kVA Power Terminal Positions**

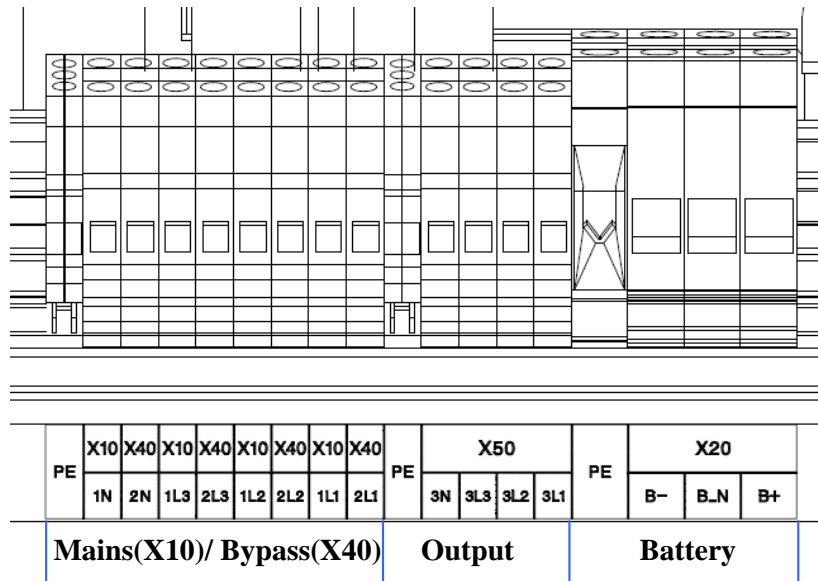

**20kVA Power Terminal Positions**

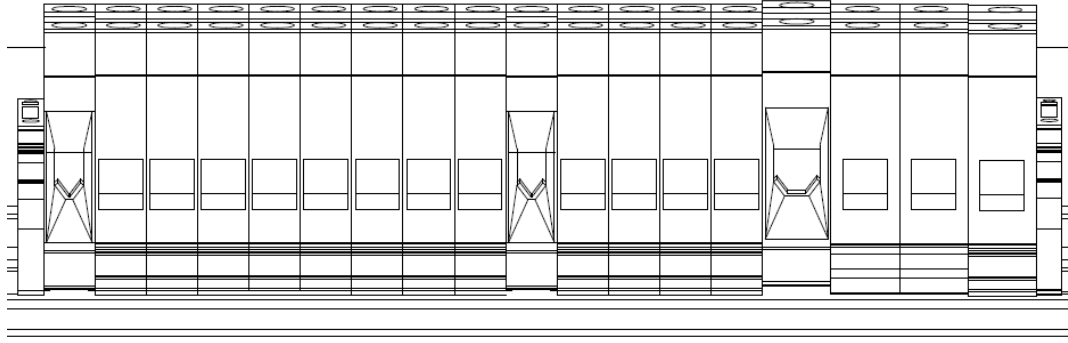

PE	X10	X40	X10	X40	X10	X40	X10	X40	PE	X50				PE	X20		
	1N	2N	1L3	2L3	1L2	2L2	1L1	2L1		3N	3L3	3L2	3L1		B-	B_N	B+
<b>Mains(X10)/ Bypass(X40)</b>									<b>Output</b>					<b>Battery</b>			

**30kVA Power Terminal Positions**

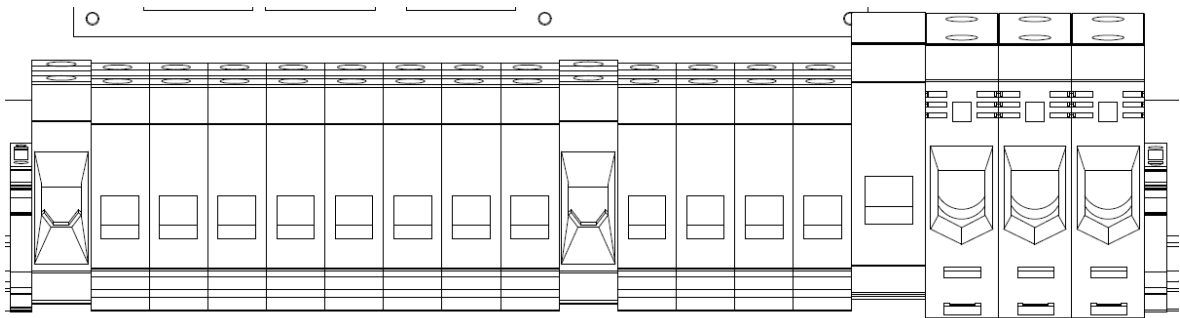

PE	X10	X40	X10	X40	X10	X40	X10	X40	PE	X50				PE	X20		
	1N	2N	1L3	2L3	1L2	2L2	1L1	2L1		3N	3L3	3L2	3L1		B-	B_N	B+
<b>Mains(X10)/ Bypass(X40)</b>									<b>Output</b>					<b>Battery</b>			

**40kVA Power Terminal Positions**

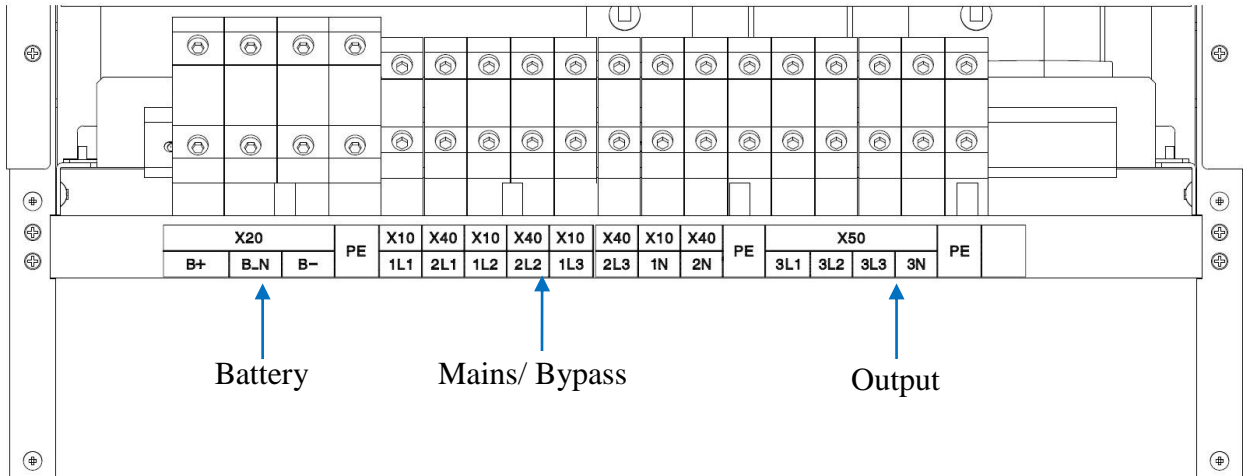

### 60kVA Power Terminal Positions

- Maximum Current

Input/ Output Voltage	Output Power	Maximum Input Current <sup>(1)</sup>	Max. Output/ Bypass Input Current <sup>(2)</sup>	Max. Battery Discharge Current <sup>(3)</sup>
380 V	10kVA/10KW	19 A	15 A	35 A
	20kVA/20KW	38 A	30 A	69 A
	30kVA/30KW	57 A	46 A	103 A
	40kVA/40KW	75 A	61 A	137 A
	60kVA/60KW	113 A	91 A	206 A
400 V	10kVA/10KW	18 A	14 A	35 A
	20kVA/20KW	36 A	29 A	69 A
	30kVA/30KW	54 A	43 A	103 A
	40kVA/40KW	72 A	58 A	137 A
	60kVA/60KW	108 A	87 A	206 A
415 V	10kVA/10KW	17 A	14 A	35 A
	20kVA/20KW	35 A	28 A	69 A
	30kVA/30KW	52 A	42 A	103 A
	40kVA/40KW	69 A	56 A	137 A
	60kVA/60KW	104 A	83 A	206 A

<sup>(1)</sup> The UPS is operating at rated voltage, rated power and batteries are charging but regardless of the overload.

<sup>(2)</sup> The UPS is operating at rated voltage and rated power but regardless of the overload.

<sup>(3)</sup> 12Vbattery blocks × 32pcs. The UPS is operating at rated voltage and rated power but regardless of the overload.



• Recommended Size of Cables

Capacity	Mains Input <sup>(1)</sup>		Output/ Bypass Input <sup>(1)</sup>		External Battery <sup>(1)</sup>	
	R/S/T/N	PE	R/S/T/N <sup>(2)</sup>	PE	+/-/N	PE
10kVA	5 mm <sup>2</sup>	3 mm <sup>2</sup>	5 mm <sup>2</sup>	3 mm <sup>2</sup>	8 mm <sup>2</sup>	3 mm <sup>2</sup>
20kVA	8 mm <sup>2</sup>	5 mm <sup>2</sup>	6 mm <sup>2</sup>	5 mm <sup>2</sup>	16 mm <sup>2</sup>	8 mm <sup>2</sup>
30kVA	16 mm <sup>2</sup>	8 mm <sup>2</sup>	13 mm <sup>2</sup>	8 mm <sup>2</sup>	30 mm <sup>2</sup>	10 mm <sup>2</sup>
40kVA	25 mm <sup>2</sup>	10 mm <sup>2</sup>	20 mm <sup>2</sup>	10 mm <sup>2</sup>	50 mm <sup>2</sup>	16 mm <sup>2</sup>
60kVA	40 mm <sup>2</sup>	16 mm <sup>2</sup>	35 mm <sup>2</sup>	16 mm <sup>2</sup>	70 mm <sup>2</sup>	25 mm <sup>2</sup>

<sup>(1)</sup> The recommended maximum length of cabling is less than 10meters.

<sup>(2)</sup> Please over size neutral line N by 1.7 times of the phase line for non-linear loads.

• Recommended Circuit Breaker Size

Input/ Output Voltage	Output Power	Mains Input <sup>(1)</sup>	Output/Bypass Input <sup>(1)</sup>
380 V	10kVA/10KW	30 A	25 A
	20kVA/20KW	65 A	50 A
	30kVA/30KW	95 A	80 A
	40kVA/40KW	125 A	105 A
	60kVA/60KW	185 A	160 A
400 V	10kVA/10KW	30 A	25 A
	20kVA/20KW	60 A	50 A
	30kVA/30KW	90 A	75 A
	40kVA/40KW	120 A	100 A
	60kVA/60KW	175 A	150 A
415 V	10kVA/10KW	30 A	25 A
	20kVA/20KW	55 A	50 A
	30kVA/30KW	85 A	70 A
	40kVA/40KW	115 A	95 A
	60kVA/60KW	170 A	145 A

<sup>(1)</sup> The sizing takes into account 150% overload capacity.

## ■ Electrical System Connections

- UPS with single Input

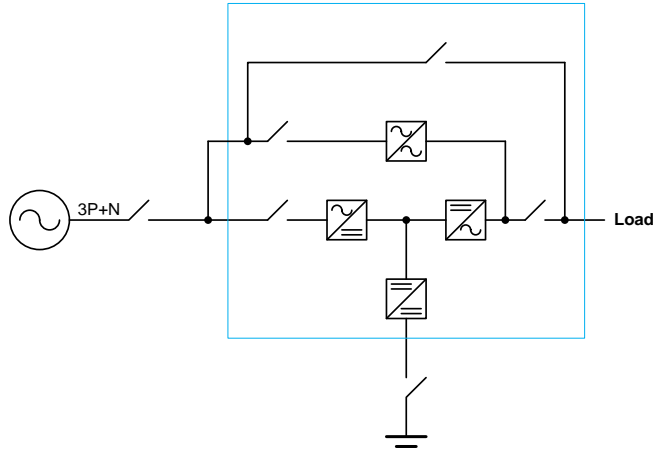

- UPS with single input and isolation transformer

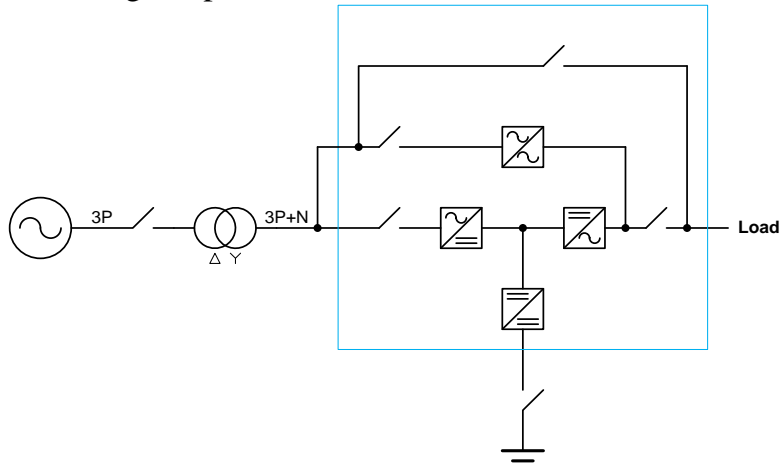

- UPS with dual inputs

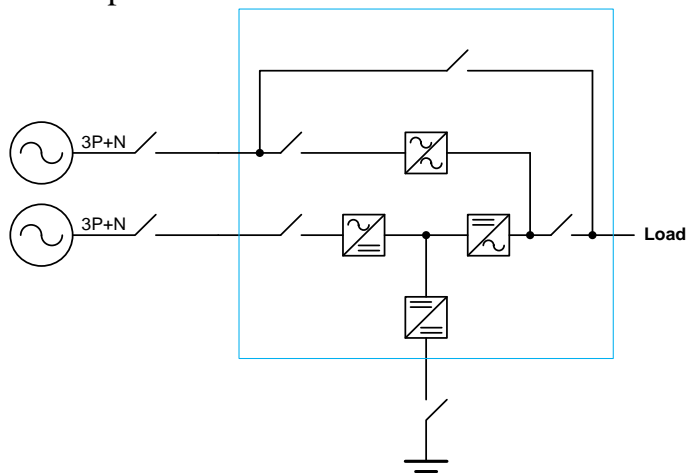

- UPS with dual inputs and isolation transformer

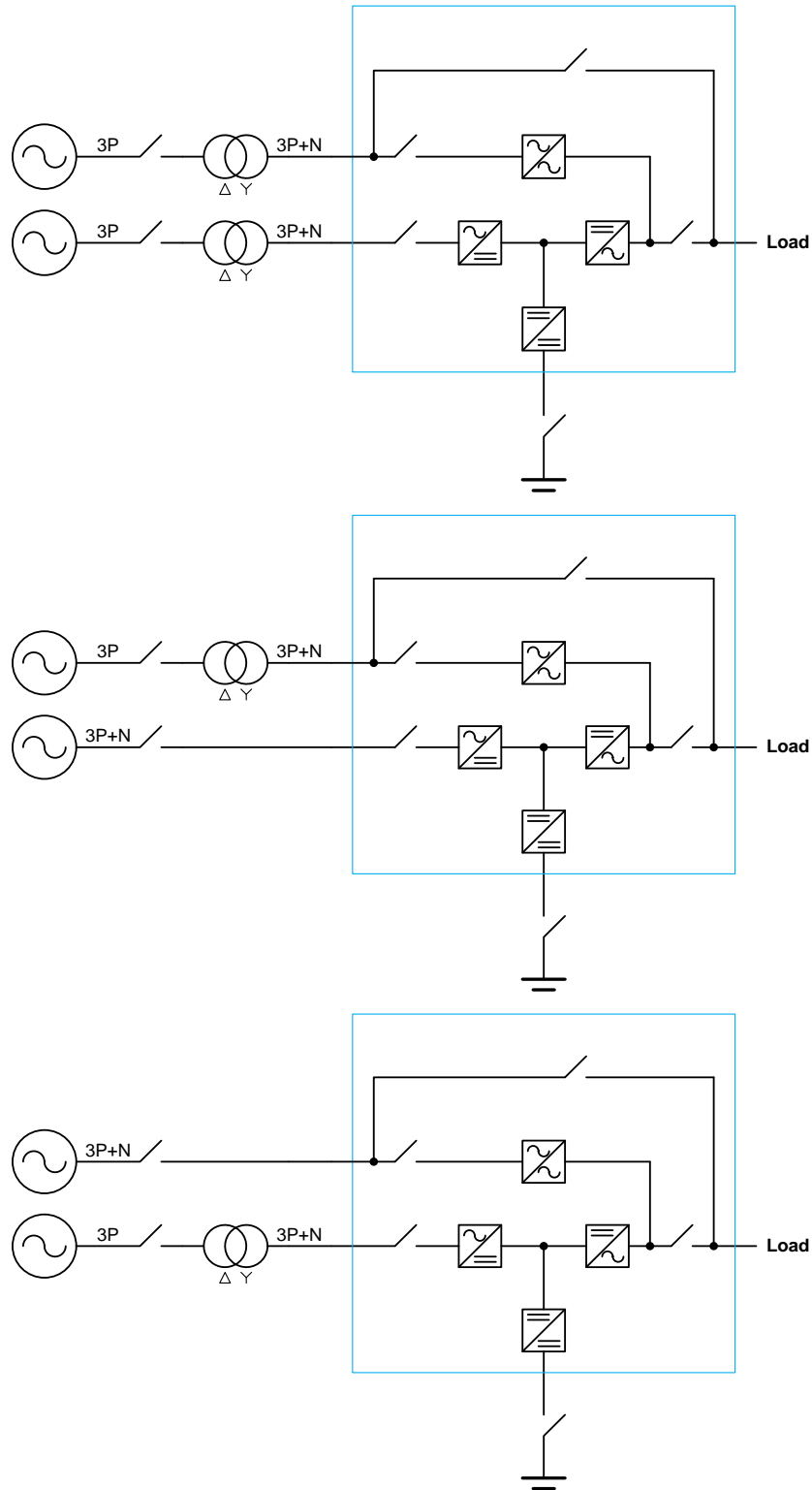

**Note :** You have to install an isolation transformer on one of the inputs if the two power system are different.



- UPS in parallel, use separate battery

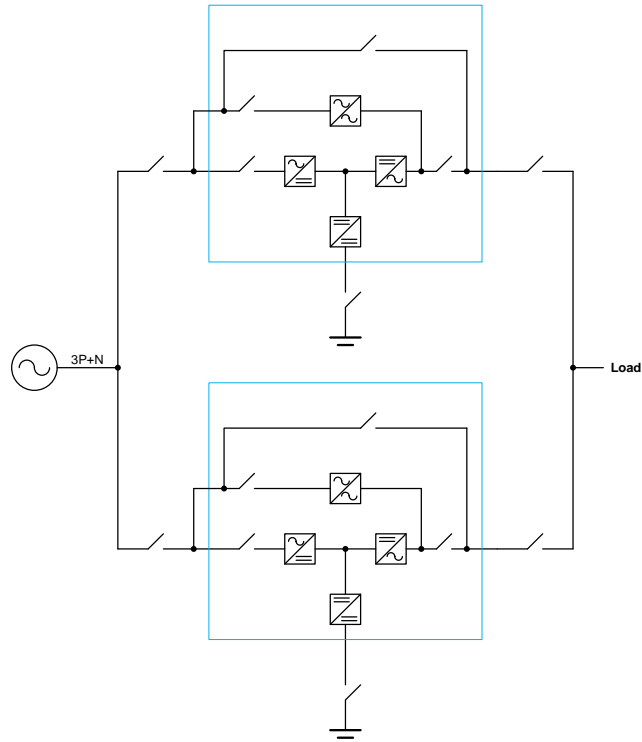

- UPS in parallel, use common battery

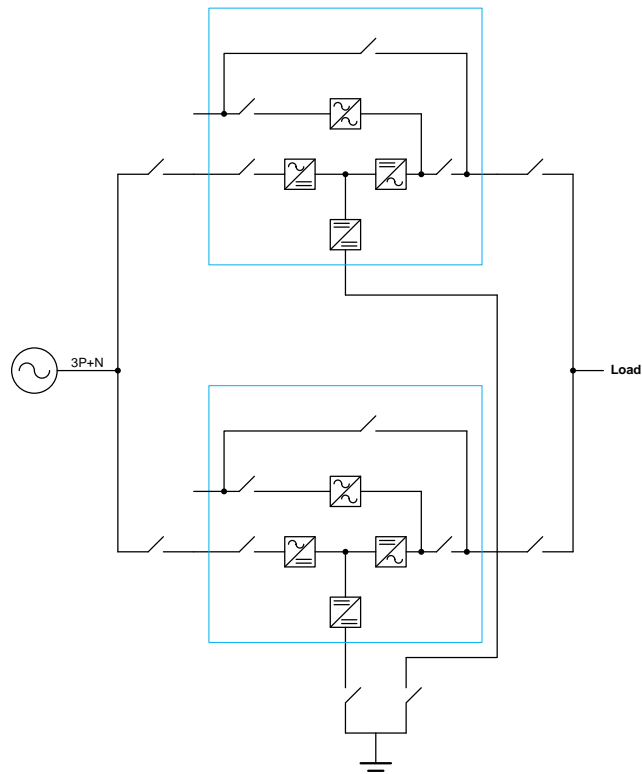

- UPS in parallel with output transformer

Please do not use separate output transformer for each UPS. A common output transformer is recommended.

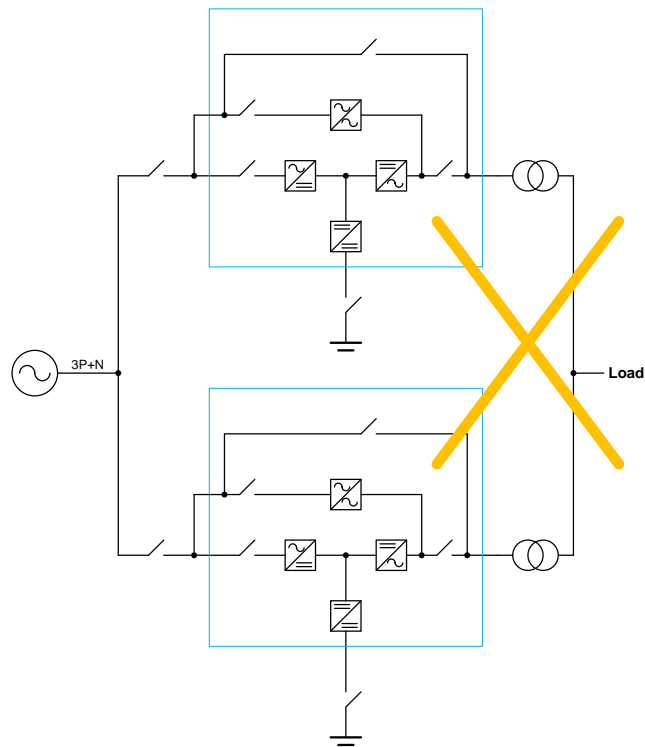
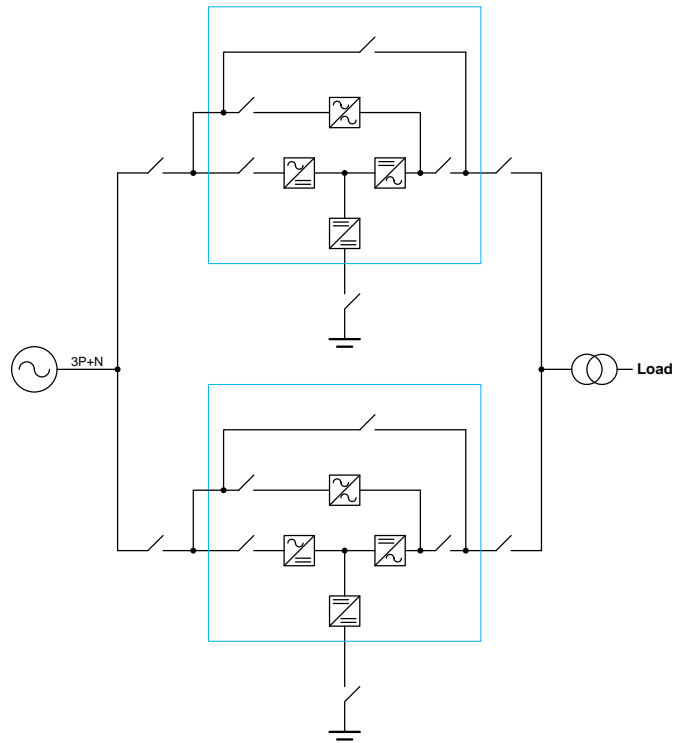

- Converter Mode

Please do not connect the bypass input.

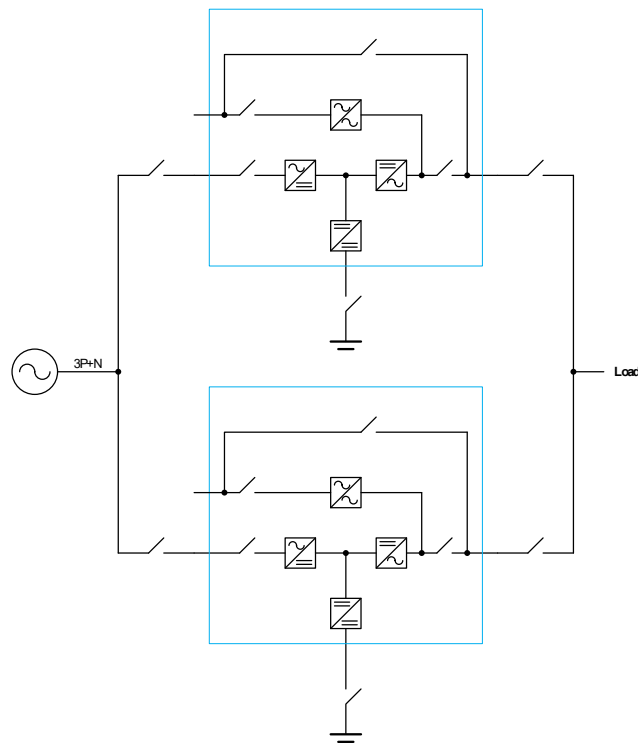
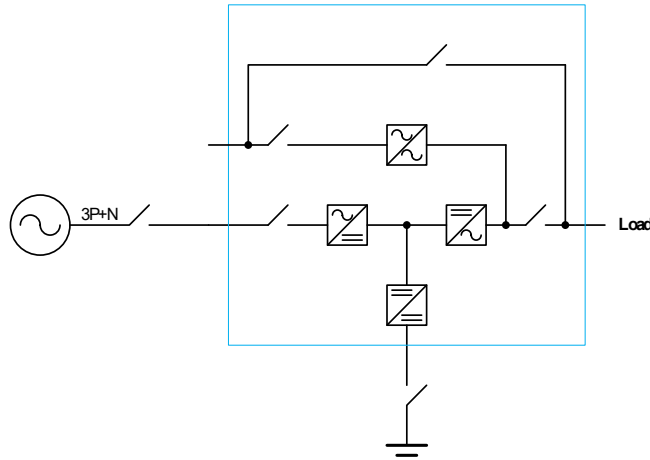

**Note : Up to 6 units can be operated in parallel for Converter Mode operation and common battery function is available.**

## 2-5 Communication Cables Connections

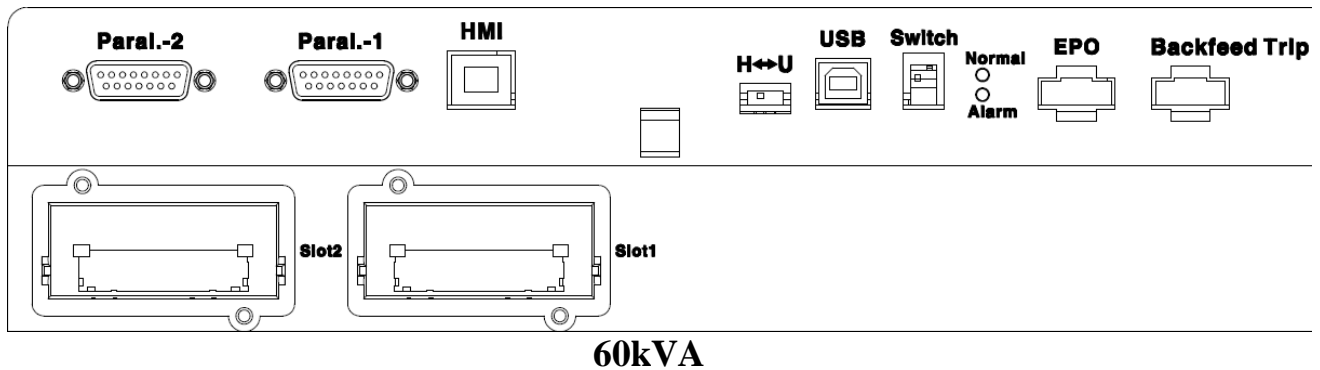
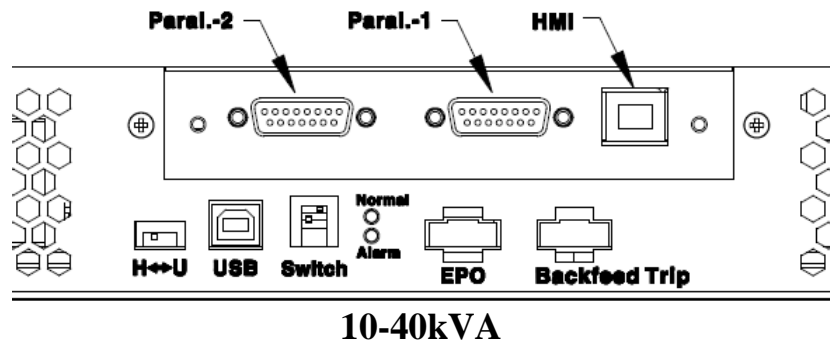

- **Paral-1& Paral-2—parallel communication port**

Parallel communication cables are required to connect UPS each other when UPSs operation in parallel. Please refer to section 2-6 for detail connections.

- **Switch—the switch for terminal resistor of parallel communication**

To ensure good parallel communication quality, please set the switch of the two farthest UPS to the “ON” position. Please refer to section 2-6 for detail.

- **HMI—communication port for control panel**

This port connects to the LCD display and control panel.

- **H↔U—communication selector**

This switch is to select HMI or USB port. Please ensure this switch on “H” position for ensure HMI port is workable.

- **USB**

This port is for service only.

■ **LED Status Indictors**

**Normal** : The UPS is normal.

**Alarm** : The UPS has some abnormal conditions.

■ **EPO-- Emergence Power Off**

This EPO contact allows you to turn off the UPS in an emergency. Short these contact to turn off the UPS immediately.

■ **Backfeed Trip**

The UPS provide a backfeed protection contact to trip the external electromechanical device for isolation from the power circuit. The backfeed protection is for ensuring personnel safety against any risk of accidental energy return to the input circuit. It imposes the automatic opening of an switching device in case of a malfunction of the static switch.

■ **Communication Slot1**

This slot can install Relay card or RS-485 MODBUS card.

■ **Communication Slot2**

This slot can install Relay card or SNMP card. Please ensure the SW2 switch to correct position when this slot is used.

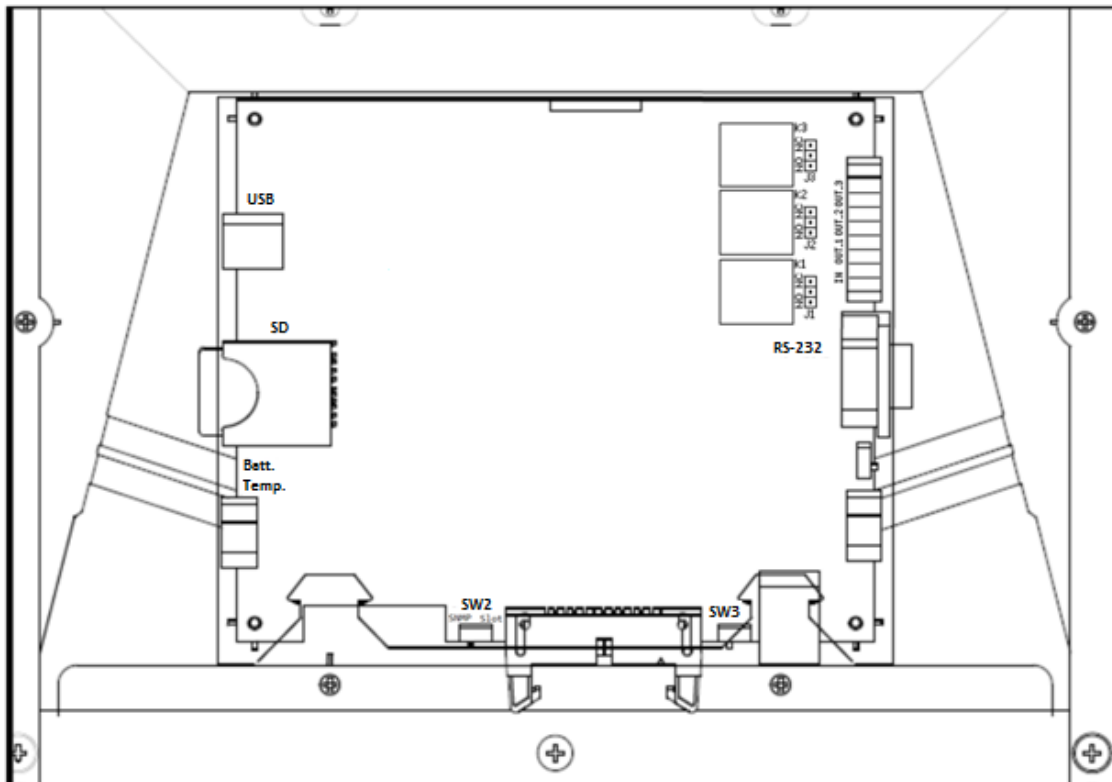

■ **USB**

Complies with USB V.2.0, 12 Mbps  
Pin Assignment:

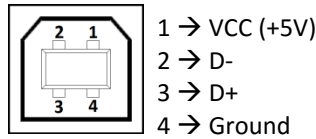

This port is available for change the setting of UPS by setting software.

■ **Batt. Temp.--External battery temperature connector**

Connect to external battery temperature sensor. Please refer to section 5-4.

■ **SW2**

When Relay card is installed in Slot2, please switch to “Slot” position.  
When SNMP card is installed in Slot2, please switch to “SNMP” position.

■ **SW3--the switch for terminal resistor of parallel communication**

To ensure good parallel communication quality please set the Switch of the two farthest UPS to the “ON” position. Please refer to section 2-6 for detail.

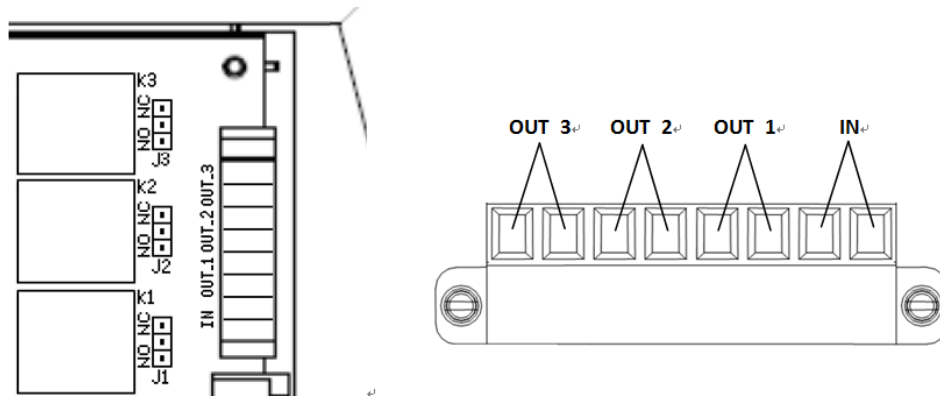

■ **Output & Input Contacts**

The UPS provides 3 output dry contacts and 1 input contact.

Specification of Output dry contact : 250 VAC/ 2 A; 30 VDC/2 A

There have 3 jumpers (J1~J3) to set NC/NO for each output contact.

To short the input contact for send a command to UPS.

The user can change the definition for each contact, please contact the local authorized service agent to change the setting.

■ **RS-232**

Pin Assignment:

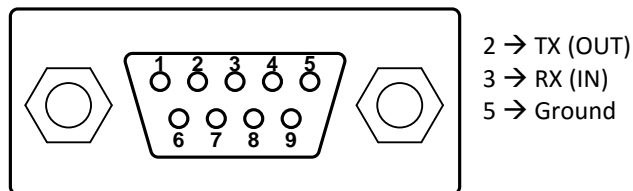

<b>Baud Rate</b>	57600bps
<b>Data Length</b>	8 bits
<b>Stop Bit</b>	1 bit
<b>Parity</b>	None

This port is available for change the setting of UPS by setting software.

## 2-6 UPS Parallel Connections

The UPS can be operated in parallel for extend the capacity and enhances system reliability.

- Up to 6 UPS units can be operated in parallel.
- The size and length of the input and output cables must be identical for all UPS units.
- The phase rotation must be the same for each UPS unit.
- It is recommended to use an external bypass cabinet to facilitate maintenance and system testing for parallel operation system.
- Parallel configuration must be performed by authorized and qualified technicians who are familiar with this UPS.
- Parallel communication cables are requested to connect to UPS each other.
- Please only use the parallel communication cables which are supplied with UPS manufacturer for ensure UPS can operate correctly in a parallel configuration.
- The parallel communication cables must be connected in a ring topology, and the maximum total length of the parallel communication cables must be less than 38 meters. To ensure good communication quality you must set the Switch & SW3 of the two farthest UPS to the “ON” position as shown in below.

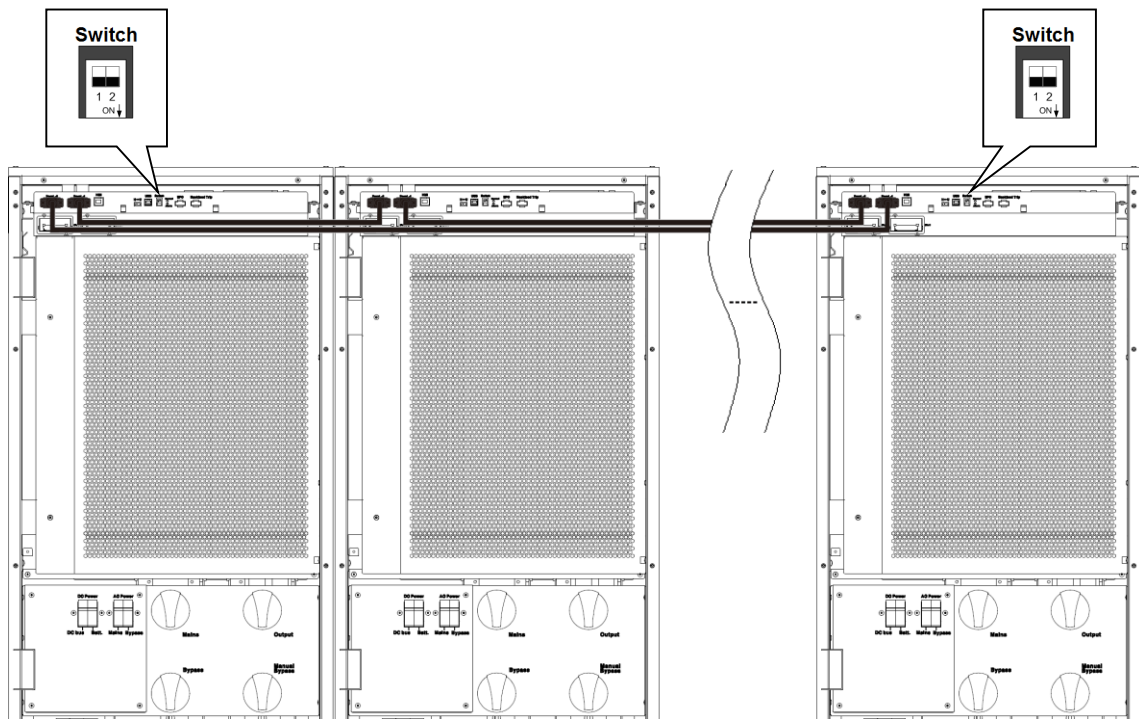



- When installing the parallel communication cables, please let the parallel communication cable through the hole at side of UPS, as shown below.

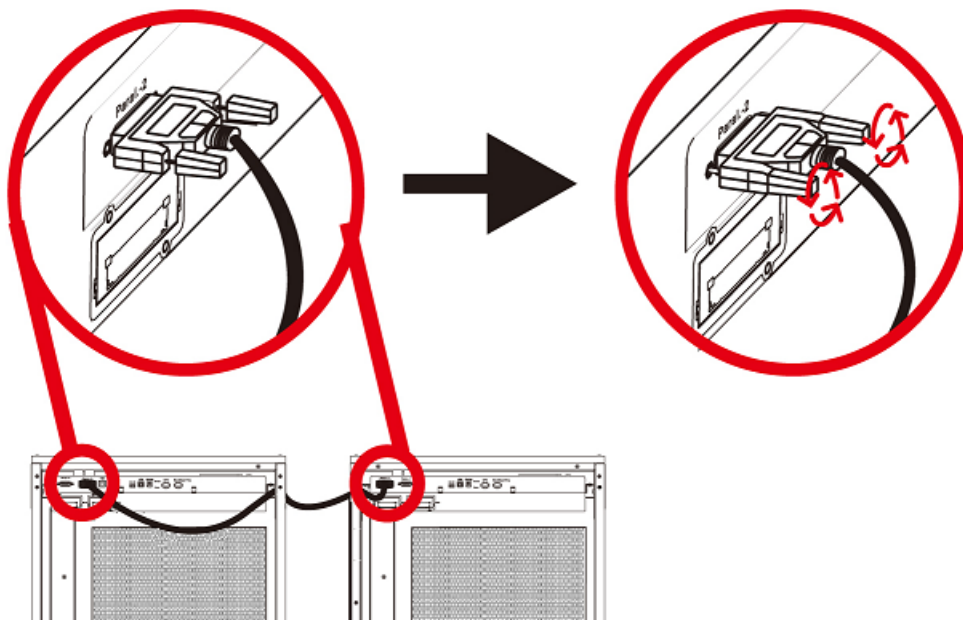
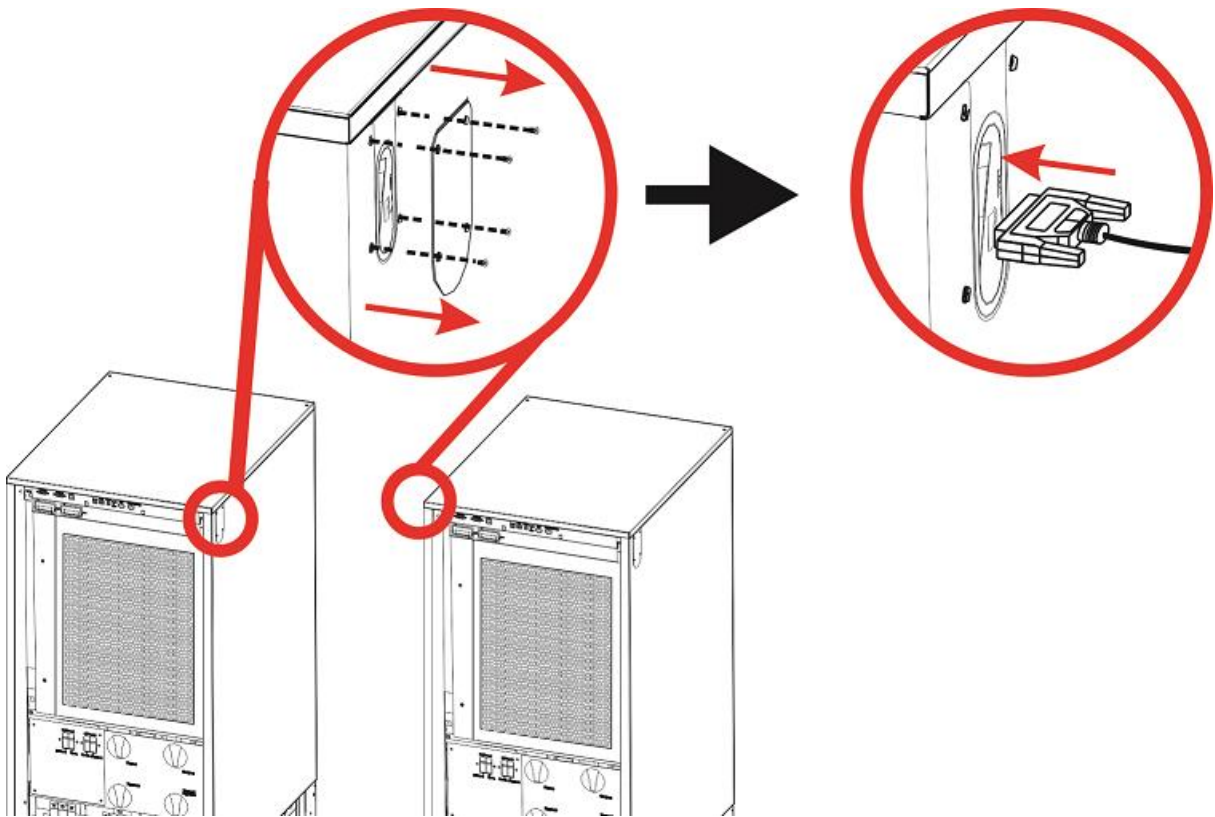

■ Recommended 1+1 parallel system configuration

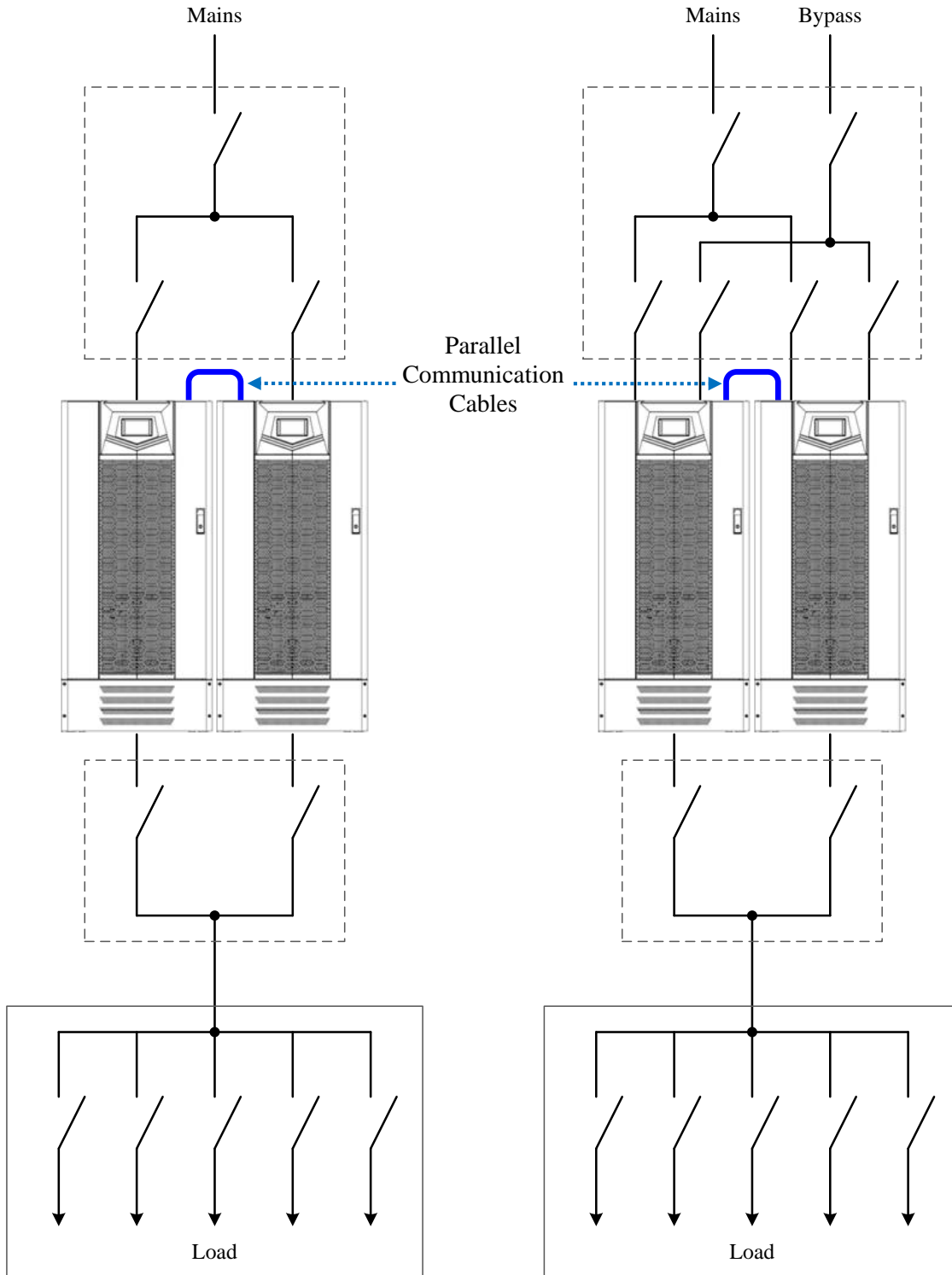

1+1 parallel, Single Input

1+1 parallel, Dual Input

■ Recommended N+1 parallel for single input system configuration

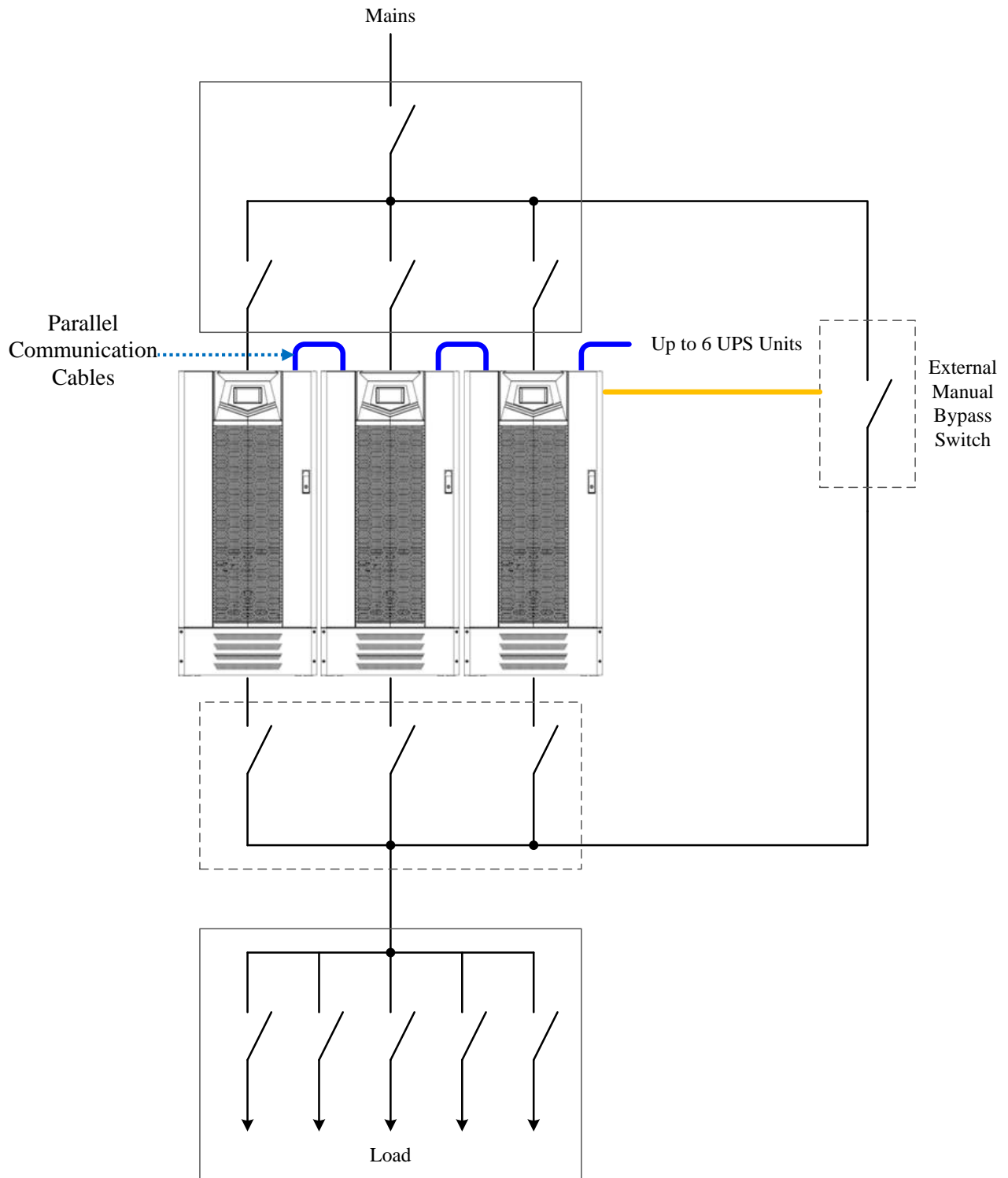

■ Recommended N+1 parallel for dual input system configuration

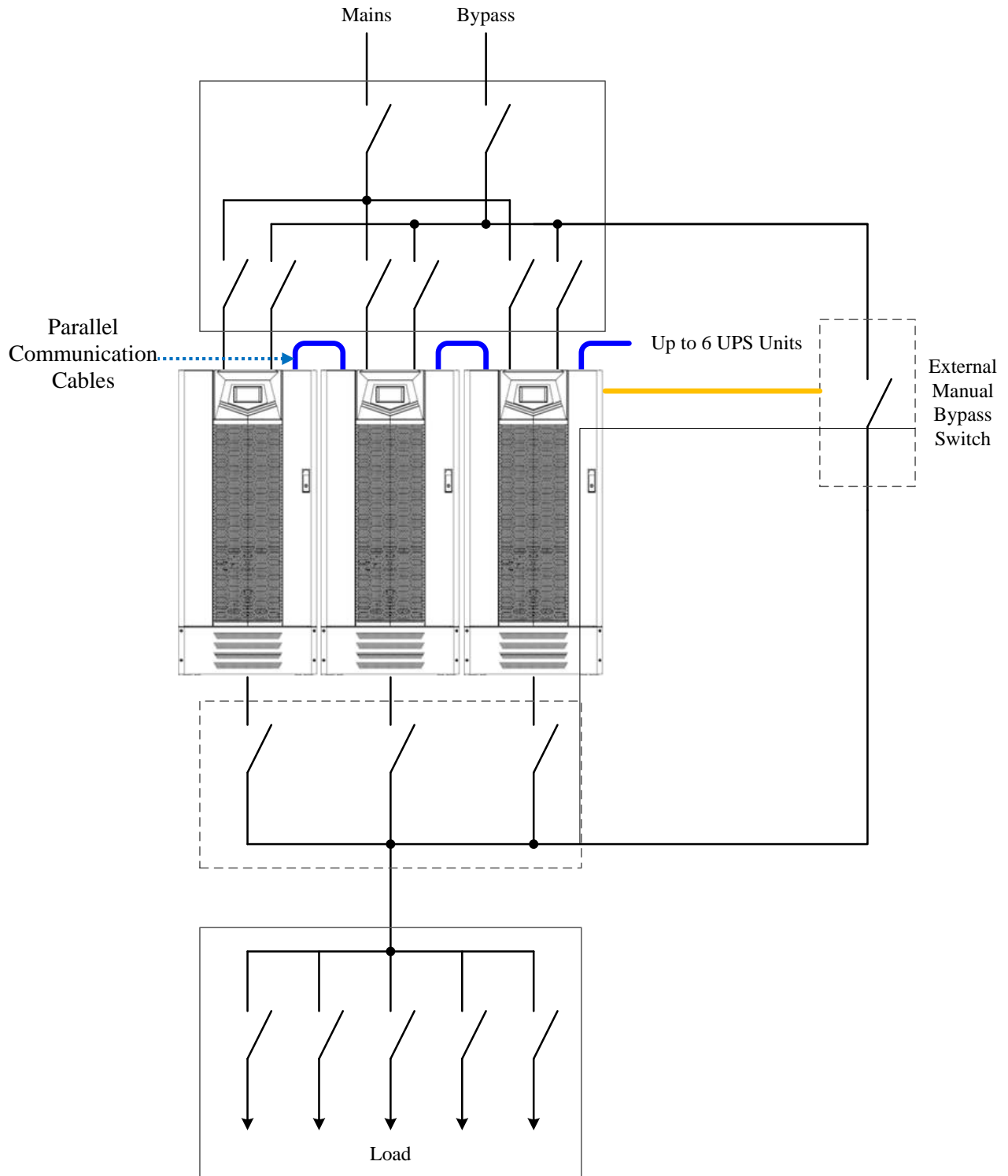



### 3. Operation Descriptions

#### 3-1 Operating Mode

The UPS provides the following operating modes:

(1) **Normal Mode (Online Mode):**

In Normal mode, grid power is passed through Rectifier then used to charge the battery and provide power through the Inverter simultaneously. Different output voltages settings can be set in VFI mode. The three options are 380/220V, 400/230V and 415/240V. These can be fine-tuned by  $\pm 8V$ .

(2) **Economy Mode (ECO):**

Economy Mode effectively improves overall efficiency. In ECO Mode grid power is routed through the Static Switch to the load. At the same time, grid power continues to charge the battery in DC/DC mode through Rectifier following the same setup as VFI Mode. Inverter is also kept ready to switch power supply modes at any time. If VFI mode is set then power can be quickly routed from Bypass to Inverter.

***Attention: In ECO Mode the power supply frequency and voltage will be less stable. Please check the load requirements and use ECO Mode with care.***

(3) **Converter Mode:**

Converter Mode allows the user to provide a power supply with constant voltage and constant frequency based on their power requirements. The frequency can be set to 50HZ or 60HZ. The voltage options are 380/220V, 400/230V and 415/240V. These can be fine-tuned by  $\pm 8V$ . When Converter mode is used, in the event of grid power failure then power is provided from the battery in Back-up mode. In the event of the battery running low, UPS overload, Inverter failure or module overheating, the entire system will shut down.



## 3-2 Online Operations

An online UPS provides stable power that is not affected by an unstable main power supply (ex. grid power). Through the online UPS, grid power can provide a clean, noise-free power supply environment.

The online architecture offers three types of power supply methods depending on the power environment.

### (1) Normal Mode:

When grid power is normal, once Rectifier has been turned on at the main power supply then the battery is charged in DC/DC mode while the required power is supplied via Inverter at the same time.

### (2) Bypass Mode:

In the event of UPS overload, Inverter failure or module overheating, the power supply circuit switches from Inverter to the bypass output.

### (3) Battery Mode:

When the UPS detects a failure in the main power supply then power is provided from the battery instead. The touch screen at the front of the module will also display current battery level to remind the user.

## 3-3 Manual Bypass Operation

When the manual bypass switch is activated, the load is powered directly from the bypass input. This operation is useful when maintenance needs to be carried out on UPS since service personnel can work on the installation without having to cut off the power to the load.

### ***Attention:***

- ***UPS maintenance can only be performed by authorized and qualified technicians who are familiar with this UPS.***
- ***If the UPS is in battery mode, turn on the manual bypass switch may cut off power to the load.***

### 3-4 Operation Processes

#### 3-4-1 Normal Mode Start-up

- (1) Close UPS Mains Input and Bypass Input Switches.
- (2) Select  → Command → Operation → Normal mode on LCD display. The UPS will be started and supply output voltage.

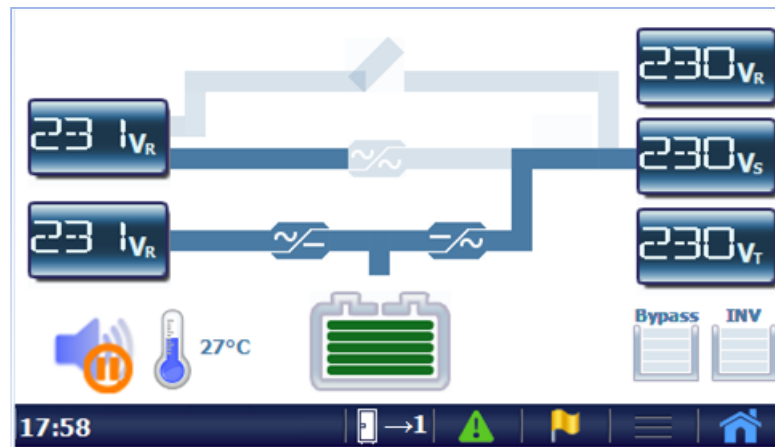

- (3) Close UPS Output Switch to supply the power to the load.

#### 3-4-2 Cold Start

- (1) User can start-up UPS by battery when main input power is not available.
- (2) Select  → Command → Operation → Cold start precharge ready on LCD display.
- (3) Select Normal mode to start UPS.

#### 3-4-3 Shutdown

- (1) Select  → Command → Operation → Shutdown on LCD display.

#### 3-4-4 Switch to bypass

- (1) Select  → Command → Operation → Shutdown converter except bypass on LCD display.
- (2) The Inverter will be shutdown and bypass will supply the power to the load. If the battery is disconnected, Rectifier and Charger will be shutdown as well.

## 4. Control Panel Operation and Function Description

Each UPS is equipped with a LCD touch panel to provide the user with a simple and intuitive user interface that is easy to learn. The touch panel offers a combination of graphics and numbers that make it easy to determine the input/output voltage, frequency, load and battery level at a glance. The current status of the UPS is displayed at the main screen. User also can have the real time input/output voltage, frequency, current and battery information from the touch panel.

Please refer to below section for learn more detail information and functions of the LCD touch panel.

### 4-1 Screen Introduction

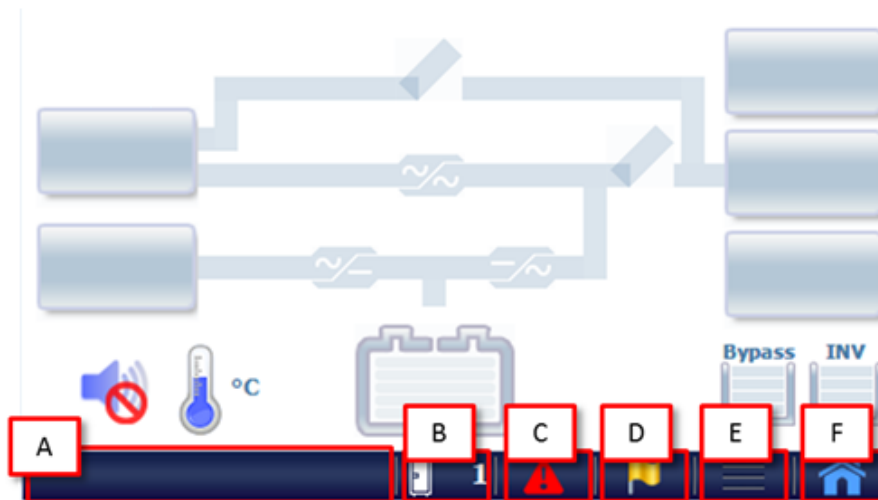

【A】 Display current time, status and information of UPS.

【B】 Indicate Single or Parallel system, and select the desire UPS unit to check the information.

: Single Unit

: Parallel System

【C】 Click here to see the alarm message.

: The green pattern indicates that UPS is normal.

: The red pattern indicates that UPS abnormal conditions occurred.

【D】 Click here to see the status.

【E】 Enter to Sub-Menu, please refer to section 4-2 for more detail.

【F】 Enter to Menu, please refer to section 4-2 for more detail.



## 4-2 Menu



Click to enter to Menu screen as shown in above picture. Slide the screen to switch to other menu page and click the menu icon to enter to the desire function.

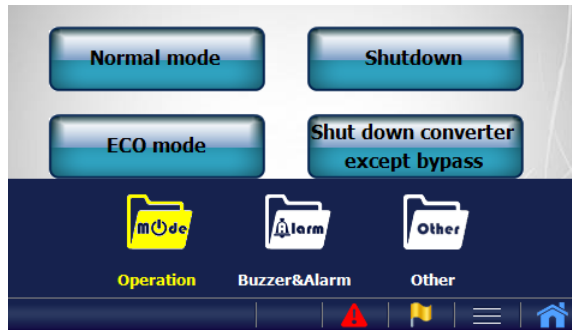

Click to hide/show the sub-menu.

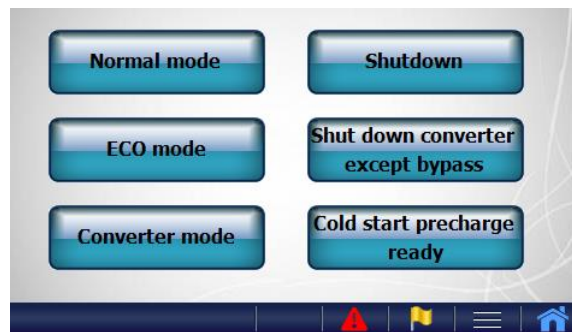

The button below will appear on some function pages.

Button	Function
	Click it to save the new setting
	Click it to reload the data
	Click it to go to Mimic Display



All menu functions are showing in below table.

<b>Menu</b>	<b>Sub-Menu</b>	<b>Functions</b>
<b>Mimic Display</b>		Display the UPS status \ alarm \ operating mode and measurements. Please refer to section 4-3 for more detail.
<b>Command#1</b>	Operation	<ul style="list-style-type: none"> <li>• Normal mode</li> <li>• ECO mode</li> <li>• Converter mode</li> <li>• Shutdown</li> <li>• Shut down converter expect bypass</li> <li>• Cold start precharge ready</li> </ul>
	Buzzer & Alarm	<ul style="list-style-type: none"> <li>• Enable/Disable Buzzer</li> <li>• Clear latch alarm and buzzer.</li> </ul>
	Other	<ul style="list-style-type: none"> <li>• Recover backfeed protection signal</li> <li>• Battery Test</li> </ul>
<b>Monitor</b>	Identification	Display UPS information
	Real Time Information	Display real time measurements of input, output, bypass and battery.
	Maintenance Code	Display the maintenance code for technician to check the status of the UPS.
	Version	Display the control MCU software and firmware version.
<b>Configuration</b>	Alarm	Set alarm latch function. <ul style="list-style-type: none"> <li>• General Alarm</li> <li>• Mains Alarm</li> <li>• Bypass Alarm</li> <li>• Over Temperature</li> <li>• Battery Low</li> <li>• Inverter Overload</li> <li>• Bypass Overload</li> <li>• Emergency Stop</li> </ul>
	Main	Select the measurements on Mimic Display.
	Bypass	
	Output	



Menu	Sub-Menu	Functions
<b>Management</b>	Schedule	Display the schedule.
	Schedule Setting <sup>#1</sup>	To define the schedule for ECO mode.
	Battery Test Schedule <sup>#1</sup>	To define the schedule for battery test.
<b>Setting</b>	Language	Select the display language
	Update Prog.	Upgrade the software of LCD touch display.
	General	Set the turn off time of LCD backlight.
	Date and Time	Set date and time.
	Peripherals <sup>#1</sup>	Set communication card.
<b>Event Log</b>		Display the event log list of UPS.
<b>Log on Load</b>		Display the history curve of loading. (Up to 7 days data).
<b>Permission Setting</b>	Login/Logout	Login with the password <sup>#2</sup>
	Password Modification <sup>#1</sup>	Chang user password.
<b>Maintenance<sup>#1</sup></b>	Screen Calibration	Calibrate the touch screen.

<sup>#1</sup> This function menu only appear after login, please refer to “Permission Setting”.

<sup>#2</sup> Default password is “3366”.

### 4-3 Mimic Display

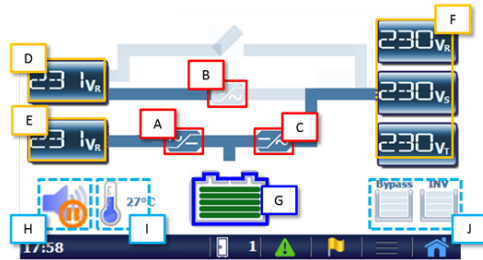

【A】 is Rectifier 、 【B】 is Static Switch and 【C】 is Inverter.

The fade pattern indicates this part isn't activated.

The blue pattern indicates this part is activated.

The red pattern indicates this part is occurred abnormal condition.

【D】 display the bypass input measurements.

【E】 display the mains input measurements.

【F】 display the output measurements.

The abnormal measurements will have red background

Click 【D】 【E】 【F】 to change the measure parameter and press for 3 second to enter to Real Time Information.

【G】 display the status of battery.

Press it for 3 second to enter to Real Time Information.

The battery isn't connected.

The green pattern indicates the battery is charging.

The yellow pattern indicates the battery is discharging.

【H】 Alarm silence button. Click it to silence the alarm and press for 3 seconds to enable/disable the buzzer.

Buzzer is enabled.

Buzzer is disabled.

【I】 Display UPS internal temperature.

Press for 3 seconds to enter to Real Time Information.

【J】 Overload counter

## 5. Options

### 5-1 Dry Contact Card



This card provides six output dry contacts and six input contact. These contacts are programmable and user can change the definition for each contact. Please refer to Dry Contact Card manual for more detail.

### 5-2 RS-485 MODBUS Card



RS-485 ports with JBUS/MODBUS protocol. Please refer to RS-485 Card manual for more detail.

### 5-3 SNMP Card



This is the Ethernet network card with TCP/IP, HTTP and SNMP protocols.

### 5-4 Temperature Sensor

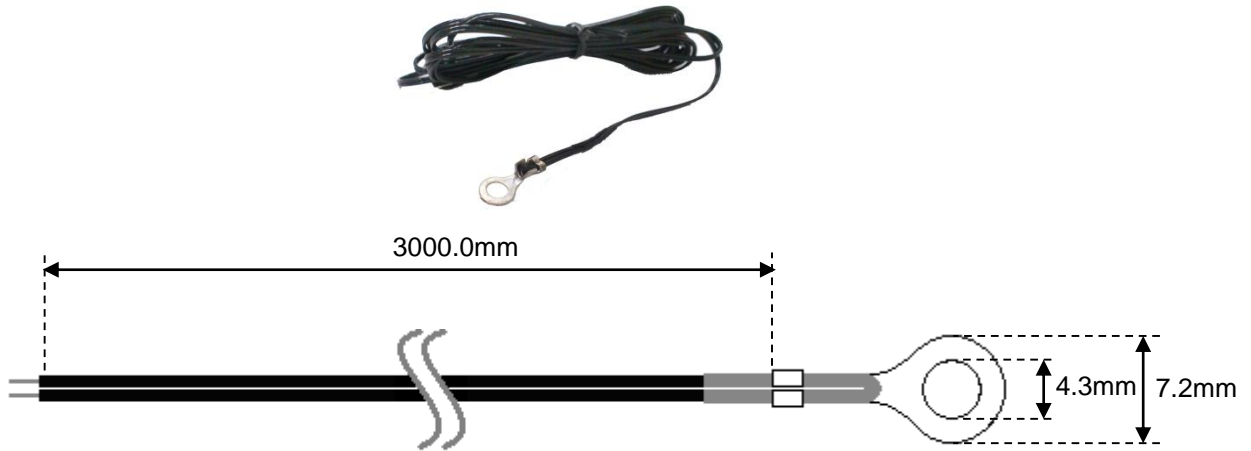

Measure the battery temperature.

### 5-5 DC Cold Start Kit

This kit allows UPS start-up by the battery without mains input.

### 5-6 Parallel Communication Cable



The parallel communication cables are required when UPS in parallel. Each UPS provides a 1.5 meters parallel communication cable as standard and it can use for 2 UPS in parallel. A longer parallel communication cable is available for more UPS in parallel.

## 6. Troubleshooting

In the event of failure, the display area on the control panel will highlight the problem area in red. The “Alarm” symbol will also blink to warn that there is a problem with the UPS. Click to have a alarm list as below picture.

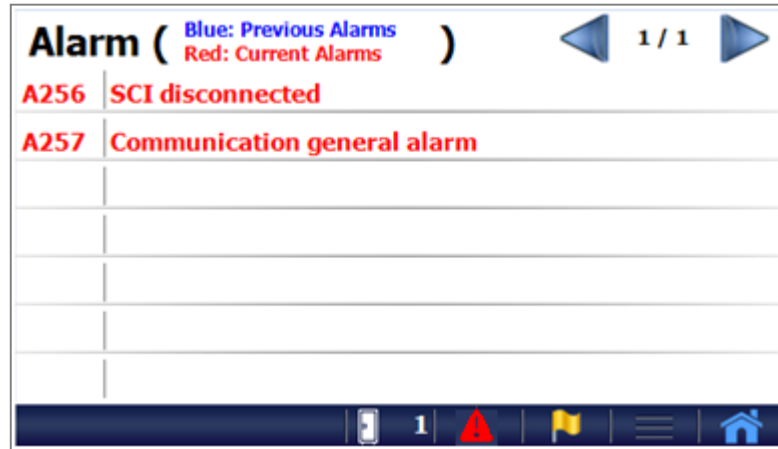

We recommend checking the error code using the following method when troubleshooting :

Click → **Information** → **Maintenance Code** to bring up the screen shown below. If you can provide the maintenance code to the authorized distributor, this will speed up troubleshooting. You also can click “Export” to save the maintenance code in SD card.

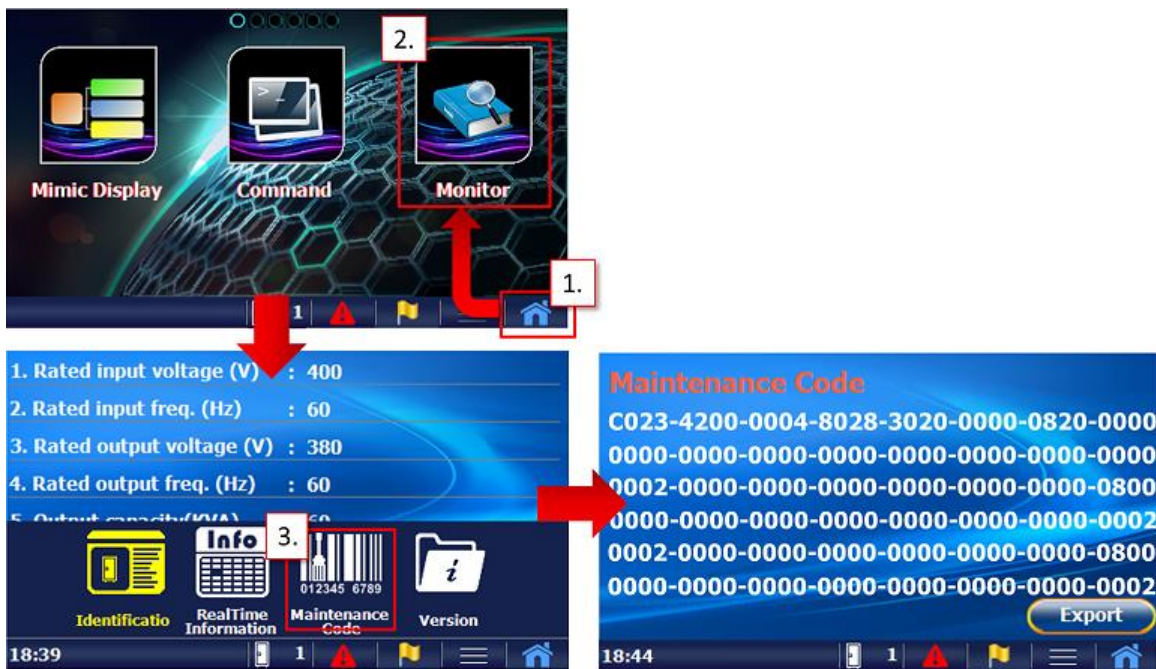

## 7. Technical Specification

Model	X33 TE 10	X33 TE 20	X33 TE 30	X33 TE 40	X33 TE 60
Capacity	10 kVA	20 kVA	30 kVA	40 kVA	60 kVA
<b>Input</b>					
Voltage	400V 3 Phase + N				
Voltage Tolerance	±20% @ 100% load -40% ~ -20% @ 50% load				
Frequency	45 ~ 65Hz				
Power Factor	≥0.99				
THDi	< 3%				
<b>Output</b>					
Voltage	380/400/415V 3 Phase + N				
Voltage Tolerance	±1% (Static Load)				
Frequency	50/60Hz				
Frequency Tolerance	±0.01% (free running)				
Power Factor	1.0				
Crest Factor	3:1				
Voltage Harmonic Distortion	≤1% with linear load;				
	≤3% with distorting load				
Overload	110% for 60 minutes, 125% for 10 minutes, 150% for 1 minutes				
Parallel	Up to 6 units				
<b>Bypass</b>					
Voltage	380/400/415V 3 Phase + N				
Voltage Tolerance	Preventive range ±10% (Adjustable ±5% ~ ±15%) Critical range ±25% (Adjustable ±16% ~ ±30%)				
Frequency	50/60Hz				
Frequency Tolerance	±1Hz / ±3Hz (Selectable)				
<b>Battery</b>					
Number of batteries	12V 32/34/36/38/40pcs configurable				
Max. Charging Current	3.5 A	7 A	10 A	13 A	20A
Common Battery for Parallel Configuration	Yes				
Internal Battery	Available for housing 12V 7/9Ah 40pcs x 2 strings				N.A.
<b>Maximum Efficiency</b>					
VFI Mode	>94%	>94%	>95%	>95%	>95%
ECO Mode	>98%				
Backup Mode	>93%	>93%	>94%	>94%	>94%





Model	X33 TE 10	X33 TE 20	X33 TE 30	X33 TE 40	X33 TE 60
<b>HMI &amp; Communication</b>					
Display and MMI	4.3" Colorful LCD Touch Screen				
Built-in Communication Port	RS-232, USB, EPO, Dry Contacts				
Optional Communication	2 Communication Slots for SNMP Card, RS-485 MODBUS Card, Dry Contact Card				
<b>Mechanical Characteristics</b>					
Dimensions (W x D x H) mm	440 x 860 x 1390 (Wheel type)				600 x 827 x 1253 (w/o wheel) 600 x 827 x 1345 (Wheel type)
Weight	84 kg	86 kg	130kg	132kg	194kg (w/o wheel) 200kg (Wheel type)
Protection Grade	IP20				
Color	RAL 7016 , Anthracite Grey				
<b>Environment</b>					
Storage Temperature	-20°C ~ 70°C				
Storage Humidity	≤95%				
Operation Temperature	0~40°C				
Operation Humidity	0~95% (w/o condensation)				
Operating Altitude	<1000 m without derating #1				
Tested to standards	LVD: EN62040-1				
	EMC requirements: EN62040-2				
Mark	CE				
Noise (at 1 meter)	<52dBA	<52dBA	<56dBA	<56dBA	<60dBA

#1 Over 1000m above sea level, the maximum output capacity must be derated by 1% every additional 100m.



---

## SERVICE CONTACTS:

---

Fon: +49 (0)9122 79889-0

Fax: +49 (0)9122 79889-21

Email: [service@alphatechnologies.de](mailto:service@alphatechnologies.de)

Web: [www.alphatechnologies.com](http://www.alphatechnologies.com)

---

ALPHA TECHNOLOGIES GMBH | HANSASTR. 8 | D-91126 SCHWABACH | GERMANY

**Power**



## CONTACT INFORMATION

Alpha Technologies GmbH

[www.alphatechnologies.com](http://www.alphatechnologies.com)

Hansastraße 8 – 91126 Schwabach –  
Germany

Tel.: +49 (0)9122 79889 – 0

Fax: +49 (0)9122 79889 – 21

[sales@alphatechnologies.de](mailto:sales@alphatechnologies.de)

192321262006003