

CFV II 50C



HASSELBLAD

1	INTRODUCTION	6
1.1	CFV features	7
1.2	Included items	9
1.3	CFV II 50C technical specifications	10
1.4	System requirements	11
1.5	Older cameras - focusing	11
1.6	New in this version	11
1.7	About this user guide	11
1.8	Glossary	12
1.9	Update camera firmware	12
1.10	Connectivity Chart - Mechanical Shutters	13
1.11	Connectivity Chart - Electronic Shutter	14
2	QUICK START	15
2.1	Quick start	16
	Firmware	16
	Battery	16
	SD card	16
	Mounting the focusing screen mask	16
2.2	Charging the battery	17
	Battery charger	17
	Charge the battery	17
	Charging from the USB port	17
	Attach the CFV to the camera	18
	The first capture	19
	Viewing the first capture on the computer	20
3	SAFETY	21
3.1	Safety and warnings	22
3.2	Cautions	22
3.3	Disposal	23
3.4	FCC	24
3.5	ISED	24
4	PARTS & CONTROLS	25
4.1	Parts, components, buttons and controls	26
4.2	Ports and connections	30
4.3	Display and screens	31
	Touch	31
	Tilt display	31
	Available screens	32
	Main menu screen	33
	To use the short-cuts	33

Add short-cut	33
Delete a short-cut	33
Re-arrange short-cuts	33
Control screen	34
Menu screen navigation	35
Browsing images	37
Browse overlays	38

5 USING THE CFV 39

5.1	Introduction	40
5.2	Basic settings	40
	White balance	42
5.3	Live view	45
	Start live view	45
	Stop live view	45
5.4	Live view overlays	46
5.5	Live view Settings	47
5.6	Focusing using live view zoom	48
5.7	Focusing using focus peaking	49
5.8	Long exposures	50
5.9	Exposure time in Meta Data	50
5.10	The CFV on a 500 camera	51
	Start live view with a 500c or 500c/m camera	51
	Start live view with 501 and 503 cameras	51
	Remote control of a 503CW with Winder CW	52
5.11	The CFV on a 200 or 2000 camera	53
	Start live view	53
5.12	The CFV on an SWC camera	54
	Start live view with a SWC camera	54
5.13	The CFV on an EL type camera	55
	Start live view with a EL camera	55
5.14	The CFV on an ELD camera	56
	Start live view with a ELD camera	56
	Remote control of a EL-type camera	57
5.15	The CFV on a camera using Flash-Sync	58
	Start Live View with a Camera using Any (Flash Sync)	58
5.16	The CFV on a Camera using the Electronic Shutter	59
	Start live view with electronic shutter	59
	Additional settings for electronic shutter	60
	B and T Mode exposures	61
	Self timer settings	63
	Interval settings	64
	Interval operation	65
	Exposure bracketing settings	66

5.17	Working with flash	67
5.18	Image Rating	69
	Rating Function	69
5.19	Video Recording	70
5.20	Video Playback	71

6 SETTINGS 72

6.1	The Camera settings menu	73
	Camera body	73
	Crop & Orientation	74
	Quality	77
	Focus	78
	Configuration	81
6.2	The Video settings menu	82
6.3	The General settings menu	84
	Connectivity	84
	Display	86
	Preview	87
	Storage	88
	Recommended memory cards	88
	Sound	90
	Date & Time	91
	Power	93
	Spirit Level	95
	Calibrate Spirit Level	96
	Language	97
	Service	98
	Service Settings-Firmware update	99
	Service Settings-Save Log	100
	Service Settings-Reset Settings	101
	Service Settings-Reset File Counter	102
	About	103

7 PHOCUS 104

7.1	Phocus overview	105
	Phocus	105
	Features in Phocus	106
	Phocus Mobile 2	107
7.2	Connect to a computer	108
7.3	Connect to an iPad pro	108
	Using cable	108
	Using Wi-Fi	108

7.4	Connect the camera to an Ipad Pro over Wi-Fi	109
	Bluetooth assisted Wi-Fi connection	109
	Manual Wi-Fi connection	110
7.5	Phocus and Hasselblad capture files	111

8 ACCESSORIES 112

8.1	Accessories	113
	Rechargeable battery	113
	Battery charging hub	113
	Flash sync input cable	113
	Flash sync output cable	113
	Exposure cable EL	114
	Exposure cable 503	114
	Release Cord X	114

9 APPENDIX 115

9.1	Clean the Sensor Filter	116
9.2	Clean the Lens Glass Surface	116
	Remove Dust	116
	Remove Smear	116
9.3	Change from foreign Language	117
9.4	Error Messages	118
9.5	Information about the CFV II 50C User Guide	118
	Updates	118
	3D Product Images	118
	Trademarks	118
	Copyright	118

The CFV II 50C digital back, with its 50-megapixel CMOS medium format sensor, connects with classic Hasselblad V System cameras as well as view cameras with a V System interface. Ergonomically enhanced from the previous model with a touch and tilt rear display plus an internal battery slot, the CFV II 50C's sensor is individually calibrated for optimal performance and packed with outstanding colour depth. Please note in this User Guide that the CFV II 50C will be referred to as CFV.

1.1 CFV FEATURES

Touch screen interface

Equipped with a smart-phone style user interface, the rear touch 3 inch display allows quick and simple access to the digital back shooting settings including WB and ISO. There is also the option of adding up to 9 favourite icons to the main menu display to allow fast access to your most frequently used functions.

Tilt screen

The rear screen can be tilted upwards 90 degrees for convenient operation in many situations.

Live view

High frame rate live view is available to assist with critical focusing of the image, especially useful when the back is used on a view camera.

Dual SD media card slots

Equipped with dual UHS-II compatible media card slots, the digital back will automatically use them concurrently for storage.

Internal battery

The interchangeable and rechargeable battery is located internally behind the SD card lid. This enables the streamlined shape and design to be maintained and removes the need for angled brackets that used to be required for battery mounting on certain models. Battery type is the same that is used for Hasselblad X System cameras.

Camera support

Virtually all Hasselblad V System cameras built from 1957 onwards can be used in cable-free mode - including:

- 500 C, 500 C/M, 501 C, 503 CX / CXi / CW / CWD
- 500 EL / EL/M / ELX, ELD
- 2000 FC / FC/M / FCW, 2003 FCW
- 201 F, 202 FA, 203FE, 205TCC, 205FCC
- SWC/M, 903 SWC, 905 SWC
- FlexBody and ArcBody
- All View Cameras and Technical Cameras with a V System magazine interface.



USB 3 Type C

Simplifying and enhancing tethered shooting to your Mac or PC, the USB 3 interface allows easy connectivity with today's high speed ports.

Audio input

To enable high quality sound to be recorded the CFV has dedicated port for audio input which is handily located under the protective cover running along the lower edge of the rear display panel.

Wi-Fi options

The Wi-Fi function of the CFV uses both 2.4 and 5 GHz and has the option of 802.11 b, g, n, a, ac (a and ac depending on region) connections.

Natural accurate colours

Providing super smooth colour and tone rendition.

Huge 14 stop dynamic range

Makes it easier to keep details in both deep shadows and bright highlights. It will also allow fantastic HDR images to be assembled from less captures.

Large 43.8 x 32.9mm 50MP sensor

For unbeatable image resolution with low image noise, enabling enlargements in breathtaking quality.

Shallow depth of field

The larger size of the sensor delivers a shallower depth of field with a given focal length compared to a FF camera enabling easier separation of your subject from the background and super smooth bokeh with Hasselblad lenses delivering the "medium format look" to your images.

HNCS Hasselblad Natural Colour Solution

HNCS saves time and enables high colour quality in skin tones and specific product tones that are going to be rendered automatically and accurate.

JPEG & RAW files

The JPEG files are HNC profiled so you can print straight from a folder for amazing quality. RAW files are retained for your final masterpieces.

Digital lens corrections

The digital lens correction, which is applied at the file editing stage, uses a digital model of the lens to remove any colour aberration, distortion and light fall off however minor (which is inherent in any lens, anywhere).

Hasselblad Phocus digital imaging software

The Hasselblad Phocus digital imaging software is a capture, processing and file management application aimed primarily at Hasselblad 3F file handling. The desktop version is supplied in box with the digital back.

Phocus Mobile offers remote viewing and control when shooting tethered. Phocus Mobile is free to download at Apple's App Store for both iPhone and iPad.

Hasselblad Phocus Mobile 2 app for iOS

Use the iPad Pro to edit images directly from the camera. Phocus Mobile 2 offers remote viewing and control when shooting tethered (Wi-Fi or USB cable). Phocus mobile 2 is free to download at Apple's App Store for the iPad Pro. The CFV is not compatible with the previous version of Phocus Mobile.



1.2 INCLUDED ITEMS

The CFV is delivered with the following items.



Flash Sync input Cable



Flash Sync output Cable



Exposure Cable CW



Focusing Screen Mask
44x33mm



USB C to C Cable, 80cm



USB Charger

- Quick Start Guide
- In the Box
- Warranty Leaflet
- Disclaimer and Safety Guidelines
- Registration Card

1.3 CFV II 50C TECHNICAL SPECIFICATIONS

Camera Type	Medium Format Digital back for V System Cameras.
Construction	Machined aluminium.
Sensor Type	CMOS, 50 mega pixels (8272 × 6200 pixels, 5.3 × 5.3 µm).
Sensor Dimensions	43.8 × 32.9 mm.
Image Size	Stills: 3FR RAW capture 106 MB on average. JPEG: Up to 22 MB, TIFF 8 bit: 154 MB. Video: 2.7k (2720 x 1530) and HD (1920 x 1080), max 29:59 minutes/clip). Video covers the full sensor width in a 16:9 ratio.
File Format	Hasselblad 3FR RAW, Full size JPEG. Video: H.264 Compressed (29,97 fps).
Colour Definition	16 bit; Dynamic range approximately 14 stops.
ISO Speed Range	ISO Auto, 100, 200, 400, 800, 1600, 3200, 6400, 12800, 25600.
Storage Options	Dual UHS-II SD cards or tethered to Mac or PC. Max 1 TB. SD Cards can be used in Overflow or Backup (images only) mode. Recommended cards are listed on page 88.
Colour Management	Hasselblad Natural Colour Solution, HNCS.
Storage Capacity	A 64 GB card holds approximately 600 RAW or 6000 JPEG High Quality images on average.
User Interface	Touch interface including swipe, scroll and pinch/spread to zoom. Camera grip with buttons and Scroll Wheels. Many camera functions and settings can be controlled from a tethered computer or iPad Pro/iPad Air (2019) over Wi-Fi or tethered.
Display	CFV II 50C: 3.2 inch, 2.36 M dots (1024 x 768). CFV II Special Edition: 3 inch, 920 K dots (640 x 480). TFT type, 24 bit colour. Can be tilted up to 90 degrees.
Live View	On camera and host computer with high frame rate.
Histogram Feedback	Yes, in Browse Mode on rear display.
Acoustic feedback	Yes.
IR Filter	Mounted in front of sensor.
Software	Phocus for Mac and Windows. Compatible with Adobe Photoshop Lightroom® and Adobe Camera Raw® Phocus Mobile 2 for iPad Pro and iPad Air (2019).
Platform Support	Macintosh: OS X version 10.9. PC: XP/Vista/Windows 7 (32 and 64 bit)/ 8 / 10.
iOS device Support	iPad Pro or iPad Air (2019 or later).
Host Connection Type	USB 3.0 (5 Gbit/s) Type-C connector.
Additional Connections	Audio In/Out, Flash Sync input, Flash Sync output, EL Camera and Winder CW control.
Operating Temperature	-10 to 45 °C. 14 to 113 °F.
Wi-Fi	802.11 b, g, n, a, ac (a and ac depending on region).
Dimensions (W × H × D)	91 × 93 × 61 mm.
Weight	540 g. Excluding battery and SD card.
Camera compatibility	See "Camera support" on page 7 and "1.10 Connectivity Chart - Mechanical Shutters" on page 13.
Power Supply	Rechargeable Li-ion battery (7.2 VDC/3200 mAh). Plug for external DC power. See page 28.



1.4 SYSTEM REQUIREMENTS

Storage and editing of images requires certain minimum computer capabilities. Large images require a reasonably high performance computer with sufficient memory, advanced graphics capabilities and a recent operating system.

It is recommended that the computer has a USB 3 connector, which will allow you to load images more quickly from the camera. A USB SD card reader is also required for image transfer from the SD cards.

1.5 OLDER CAMERAS – FOCUSING

With the modern high-resolution sensor of the CFV, it is important that focus is set correctly. Compared to film use, the requirement for focusing accuracy has increased. It is therefore a great advantage if the camera is equipped with a modern focusing screen with split image. A magnifying loupe is also a good practice to use.

Whenever possible, we recommend that you use Live View in 100% zoom-in for focusing. This will ensure perfect results.

1.6 NEW IN THIS VERSION

This User Guide describes the functionality available with CFV II 50C firmware version 1.3.0 or later.

- **Set ISO and white balance from Live View screen using touch**

Tap the ISO value or white balance icon in Live View mode to quickly change setting. See page 47.



1.7 ABOUT THIS USER GUIDE

The CFV user guide is designed for on-screen PDF reading to take advantage of the interactivity functions and search tools.

Interactive PDF

You can navigate the user guide by selecting a chapter in the table of contents. This interactive feature is available on nearly all PDF readers, computer platforms and web browsers. All pages contain a link to the table of content and most page references also work as a clickable link.

Search tools

On most PDF readers you can use the Search Tool to find a specific subject, function or setting.

Format and printing the CFV user guide

Please note that the format is A4 to conform with the most common standard. Therefore if printing to US Letter format or similar please ensure you select "Fit to printable area" in the page scaling dialogue.

Photo Credits

Mads Selvig: 103, 104, 105, 106.

Mattias Hammar: 106.

Ian Lawson: 68

1.8 GLOSSARY

In this user guide a few different terms are used:

Tap: This means to touch a value or icon on the display with your finger briefly. This only works with a bare finger or when special touch-display gloves are used.

Double-Tap: Quickly tap the same location on the display within 1 second. This is mainly used to zoom in an image or Live View.

Swipe: A sliding movement is when you press and hold the finger and slide in one direction. This is typically used when selecting a value from a list or when panning in a zoomed-in image.

Spread: Place two fingers on the display and move them apart. Typically used for zoom in.

Pinch: Place two fingers on the display with a distance between and move the fingers together. Typically used when zooming out.

Tethering: When the CFV is connected with a USB cable to a computer or with a USB cable or Wi-Fi to an iPad.

1.9 UPDATE CAMERA FIRMWARE

The CFV can be updated with improvements and new functions.

Before you start to use your new CFV, please visit www.hasselblad.com and download the latest firmware and update the camera system to make sure you get the latest functionality.

See page 99 for an in-depth description on how to download the camera firmware and update your camera.

1.10 CONNECTIVITY CHART – MECHANICAL SHUTTERS













CFV II 50C



907X

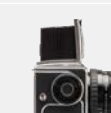

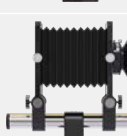
For full access to XCD Lenses. H, V, XPan and most other lenses via optional adapters. Described in detail in a separate user guide.

PHOCUS REMOTE CONTROL		503 CW / 503CWD 503 CXi + Winder CW		Exposure cable 503 CW is required for Phocus remote control of 503CW + Winder CW.
		500 EL, 500 EL/M 500 ELX, 553 ELX		Exposure Cable EL is required for Phocus remote control of EL/ELM and ELX use.
		555 ELD		
CABLE FREE OPERATION		500 C, 500 C/M 501 C, 501 CM 503 CX, 503 CXi, 503 CW, 503CWD		
		SWC/M 903 SWC 905 SWC		
		Modified 202FA, 203 FE, 205 TCC, 205 FCC With F type lenses and C/CF/CFi/CFE lenses at F- or C-mode setting.		
		2000 FC, 2000 FC/M, 2000 FCW, 2003 FCW 201 F, Unmodified 202 FA, 203 FE, 205 TCC, 205 FCC. With F type lenses and C/CF/CFi/CFE lenses at F- or C-mode setting.		
		555 ELD 500 EL / EL/M 500 ELX/ 553 ELX, 555 ELD		
FLASH SYNC INPUT CABLE ALWAYS REQUIRED		ArcBody ¹⁾		
		FlexBody		
		Any view camera with Hasselblad V System adapter ¹⁾		

¹⁾ Shift settings are not recommended on cameras with wide angle lenses and a short lens to image plane distance. E.g. the ArcBody.

CFV II 50C USER GUIDE

CONTENTS

www.hasselblad.com

1.11 CONNECTIVITY CHART – ELECTRONIC SHUTTER

When using the electronic shutter in the CFV, basically any camera with a V System mechanical interface can be used. As no mechanical shutter is used, any lens that fits the camera can also be used.

To make captures, the camera and lens must be set to open mode. See page 59 how to activate and use the electronic shutter mode.

Note!

Flash can not be used with electronic shutter

The diagram illustrates the connectivity of the CFV II 50C camera. On the left, the CFV II 50C is shown with a line pointing to the right. On the right, two camera systems are shown. The top system is a Hasselblad V System camera with a lens, connected to the CFV II 50C via a red cable. The bottom system is a 3rd party camera with a bellows, also connected to the CFV II 50C via a red cable.

CFV II 50C

Any V System camera can be used with all types of lenses that can be attached to the camera. Please see section starting on page 51 how to set the camera in open mode (same as for Live View) or dedicated user guide for the specific camera.

Any 3rd party camera with a V System mechanical interface. See the user guide for the camera how to set it in open mode.

2.1 QUICK START

This chapter explains how to make the first capture using the CFV on a 500-series camera and the default settings. A more detailed description for all compatible camera models can be found starting on page 51.

FIRMWARE

Make sure the CFV has the latest firmware by checking www.hasselblad.com. You can see which firmware that is currently installed in the CFV by following the procedure on page 103. You can find instructions on how to update to the latest version on page 99.

BATTERY

Make sure the battery is fully charged. Open the right side lid by sliding it backwards and insert the battery with the text facing backwards into the CFV. Push until the battery release catch clicks in place. **(A)**. See charging instructions on the next page.

Note!

When the battery is inserted, the rear status LED will show a blink sequence once to indicate the current battery charge level. See next page for details.

Note!

The first time you use the camera after unboxing, please remove the plastic tab on the battery before re-inserting.

Note!

If the CFV doesn't start up when a new battery is inserted, connect the camera via USB to a computer or a charger. You can also remove the battery and place it in the optional Charging Hub accessory.

SD CARD

Insert the SD card¹ into slot 1 or 2. The contact side of the card shall be facing towards the rear display. Close the lid by swinging it back and sliding it forward. **(B)**

For best results, the card should be formatted in the camera by using the procedure on page 89.

MOUNTING THE FOCUSING SCREEN MASK

The supplied focusing screen mask allows you to mask areas outside of what the sensor can capture. Place it on top of the Focusing Screen **(C)**. For a more fixed attachment, remove the backing paper and attach it using the adhesive backing. This will however, make it less flexible if the camera is also used with a regular film magazine.

¹ For compatible SD cards, see page 88.



2.2 CHARGING THE BATTERY

BATTERY CHARGER

The CFV is supplied with a USB power adapter for charging the camera battery through the USB port.





CHARGE THE BATTERY

Turn off the CFV and insert the USB-C plug from the battery charger into the USB socket on the camera **(A)**. Insert the battery charger into a standard (100-240V~ /50-60 Hz) domestic socket.

CHARGING FROM THE USB PORT

When the battery is charging, the Status Led **(B)** indicates the current charge level by blinking with Orange color. See illustration to the right. E.g. if the battery has about 50% charge level, the LED will blink two times and then be turned off for a short period. The blinking sequence is repeated.



-  One blink = 0% to 25%.
-  Two blinks = 26% to 50%.
-  Three blinks = 51% to 75%.
-  Four blinks = 76% to 95%.
-  Steady light, 4 sec. = 95% to 100%.



Note!

As a more flexible alternative, an external battery charger is available as an accessory. See page 113.

ATTACH THE CFV TO THE CAMERA

Prepare the camera by first removing the film magazine. **(A)** This is to shorten the time needed to attach the CFV in order to collect as little dust as possible on the sensor.

Remove the protective cover from the CFV by sliding the Lock Button to the left (the protective cover is facing you). Swing the cover free from the CFV and put it aside. **(B)** To minimize dust on the sensor, try to keep the time until you have attached the CFV to the camera, as short as possible. Also perform this procedure in a dust free environment.

Attach the CFV to the camera in the same way as a normal film magazine. Hold the lock button in the open position **(C)** until the CFV is fully mounted on the camera, then release the lock button **(D)**. Make sure the CFV is securely fixed to the camera.

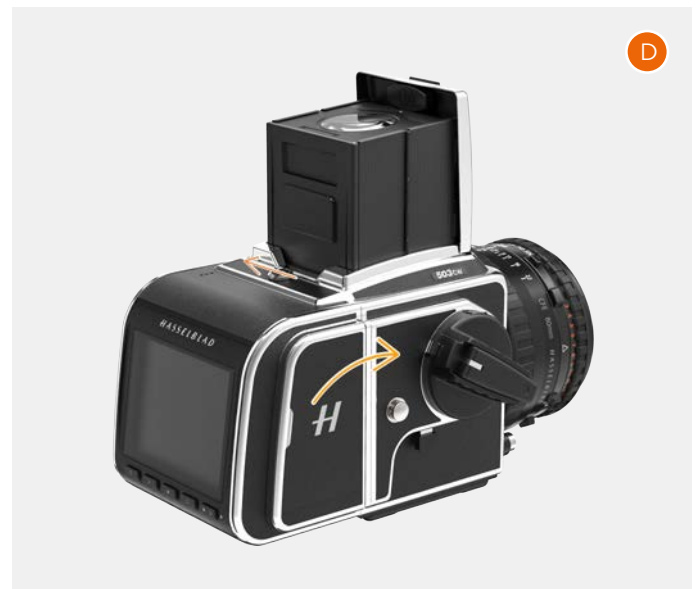
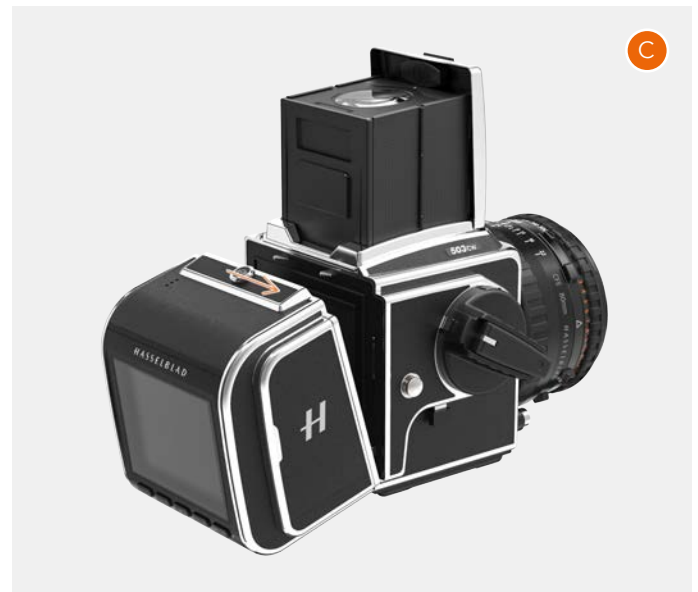

THE FIRST CAPTURE

Press and hold the power button for one second to turn the CFV on. When the status LED has turned green the camera is ready to make the first capture.

Set correct exposure parameters on the lens and release the camera. Within a couple of seconds you will see the result on the LCD **(A)**.

If no image is shown please make sure the correct camera model is set by following the procedure on page 73.

To set a different ISO value, use the following steps:

- If the display is not activated press any of the rear buttons.
- Place your finger at the top of the screen and slide down to reveal the control screen **(B)**. You can do this from any screen.
- Tap the ISO value in the top right area **(C)**. Scroll through the list of ISO values by sliding up/down and tap the required value **(D)** to confirm the new ISO value.

Note!

From the control screen you can also change white balance by tapping the white balance icon in the top left corner.

See also page 40.

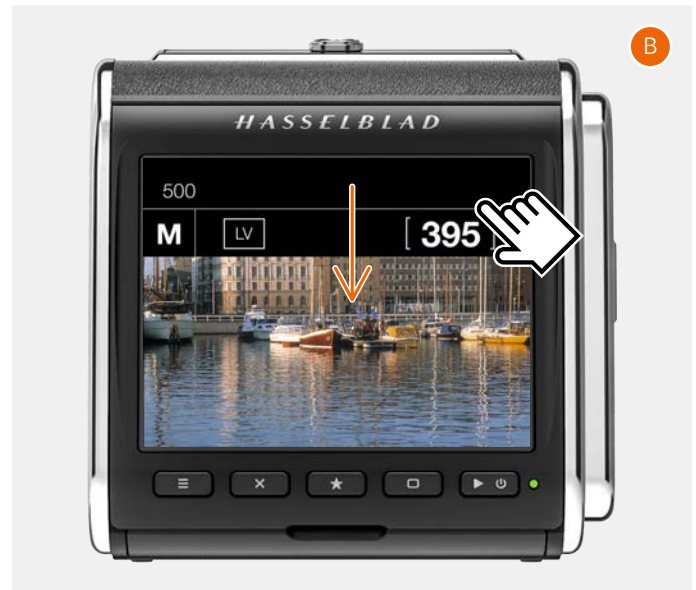

VIEWING THE FIRST CAPTURE ON THE COMPUTER

To view the image/images on the computer, you will first need to take out the SD card from the camera and place it in an SD card reader. For best performance, you should use a USB-3 version of the card reader.

The following assumes that you have installed Phocus on your computer. Phocus can be downloaded from www.hasselblad.com. Here you can also find a dedicated user guide for Phocus.

- 1 Start Phocus.
- 2 Connect the card reader to the computer.
- 3 After a few seconds, the image/images will appear in the thumbnail area **(A)**.
- 4 To be able to view the image in the large viewer window, it must first be imported. Click on the image to import and click the "Import" icon  in the top panel **(B)**.
- 5 In the dialogue that appears, select where you want to store the imported RAW file **(C)**.
- 6 Finally click on "Import" **(D)**.
- 7 After a few seconds, the image will appear in the main viewer window **(E)** and you can use all the tools to change the look as you like. Please study the separate Phocus user guide for more information.
- 8 One unique tool is the lens correction tool where you can correct the image from any distortion, chromatic aberration or vignetting. Simply enter a few parameters for the lens in the lens correction tool. The image will then be corrected for any distortion, lateral chromatic aberration and vignetting.

As an alternative you can also use Adobe Photoshop Lightroom or Adobe Photoshop to directly open the images from the card. In this case you will however, lose the possibility to correct the images for any lens distortion, vignetting or chromatic aberration.

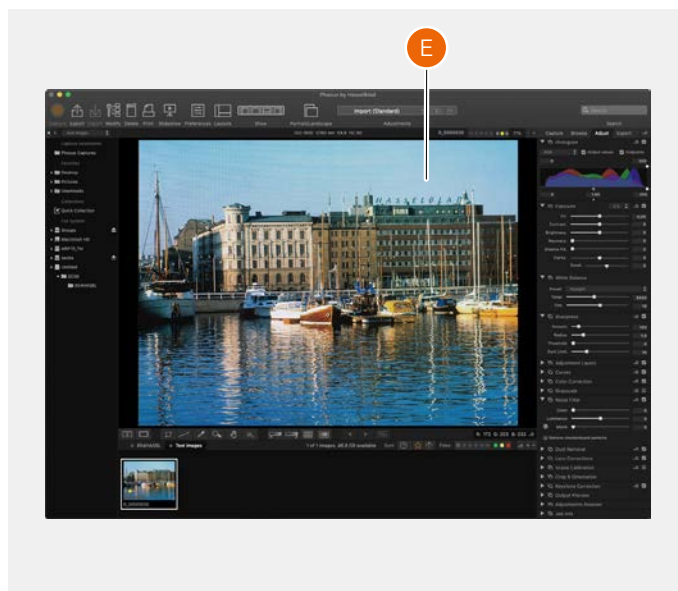
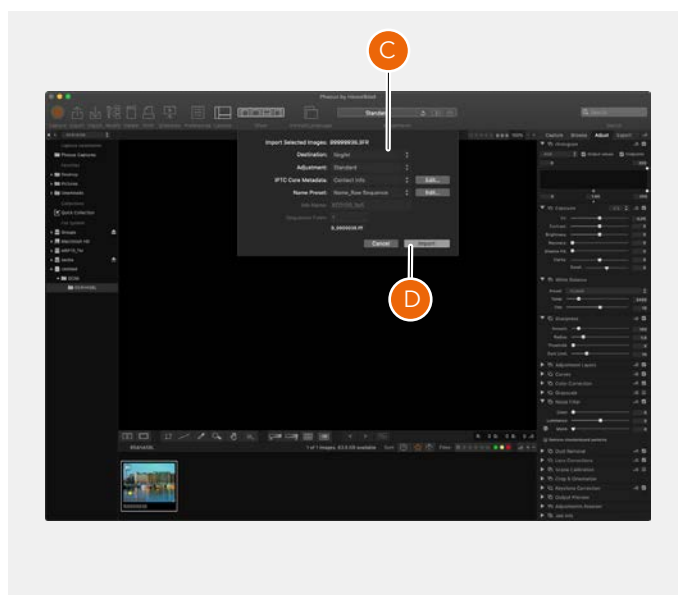
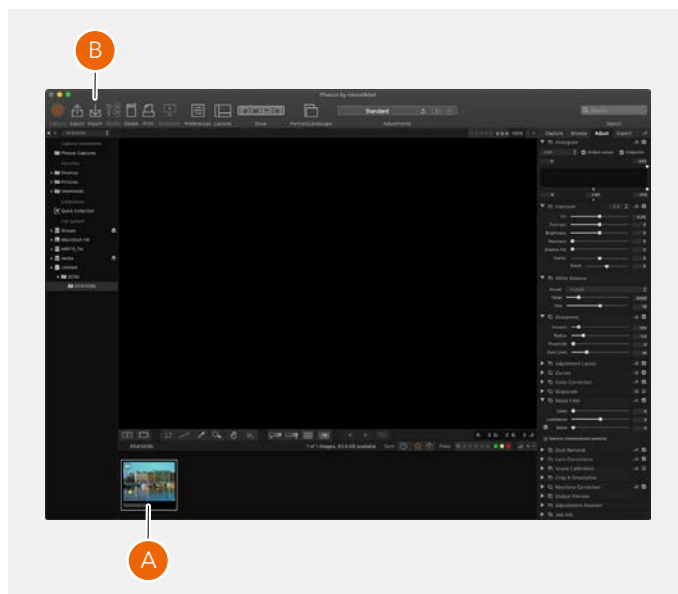

3.1 SAFETY AND WARNINGS

Warning!

Do not place cables between camera and computer so that there is a risk for people to trip and fall. This can cause personal injury and/or damage to the equipment.

Warning!

If you use spare battery packs, make sure to use protective caps on the contacts. The contacts can short circuit and catch fire, if not protected. This can cause personal injury and/or damage to the equipment.

Warning!

Do not expose batteries (battery pack and batteries installed) to excessive heat such as sunshine, fire or similar. If exposed, the batteries can catch fire. This can cause personal injury, damage to the equipment and the surrounding environment.

Warning!

Be careful when working with strobe and flash units. This will prevent personal injury and/or damage to the equipment.

Warning!

Operation of this equipment in a residential area could cause radio interference.

3.2 CAUTIONS

Caution!

Be careful when you use the camera. The camera is a precision instrument. This will help prevent damage to the camera.

Caution!

Danger of explosion if battery is incorrectly replaced. Replace only with the same or equivalent type.

Caution!

Do not use batteries other than specified. This can cause damage to the batteries.

Caution!

Use protective covers as much as possible. The protective covers will help prevent damage to the equipment.

Caution!

Use a protective case or camera bag when you transport the equipment. This will help prevent damage to the equipment.

Caution!

Protect the equipment from oil fumes, steam, humid conditions and dust. This will help prevent damage to the equipment.

Caution!

Seal all equipment in a plastic bag or similar if you enter damp and humid condition from dry and cold condition. Wait until the equipment has acclimatized to the new temperature before you remove the equipment from bag. This will help prevent damage to the equipment.

Caution!

Avoid frequent and high temperature changes. This can cause damage to the equipment.

Caution!

Keep camera and equipment away from moisture. If your camera becomes wet, disconnect from electric power and let camera dry before further use. This will help prevent damage to the equipment.

Caution!

Store the equipment in a dry environment. This will help prevent damage to the equipment.

Caution!

Be careful when you attach/detach the components to/from the camera. This will help prevent damage to the data bus connections.

Caution!

Use the grip or strap when you lift and handle to camera. This will help prevent damage to the camera.

Caution!

Do not insert fingers into the camera body. This can cause damage to the equipment.

Caution!

Do not touch the lens glass surfaces with your fingers. This can cause damage to the equipment.

Caution!

Do not touch the CMOS Sensor with your fingers. This can cause damage to the equipment.

Caution!

Keep all equipment out of reach of small children. This will prevent damage to the equipment.

Caution!

When cleaning the camera, remove the batteries. This will prevent damage to the camera.

Caution!

If you leave the camera unused for a long period, remove the batteries. This will prevent damage to the equipment.

Caution!

Do not try to remove the glass IR filter from the front of the CMOS (due to dust or similar). This can cause damage to the equipment. Always contact your local Hasselblad Authorized Service Centre.

Caution!

If you use canned compressed air to clean the glass of IR filter, read the instructions very carefully before use. This will help prevent damage to the filter.

3.3 DISPOSAL



This product must be put in municipal waste.
Check local regulations for disposal.

3.4 FCC

Federal Communication Commission Interference Statement:

This equipment has been tested and found to comply with the limits for a Class B digital device, pursuant to Part 15 of the FCC Rules. These limits are designed to provide reasonable protection against harmful interference in a residential installation.

This equipment generates, uses and can radiate radio frequency energy and, if not installed and used in accordance with the instructions, may cause harmful interference to radio communications. However, there is no guarantee that interference will not occur in a particular installation. If this equipment does cause harmful interference to radio or television reception, which can be determined by turning the equipment off and on, the user is encouraged to try to correct the interference by one of the following measures:

- Reorient or relocate the receiving antenna.
- Increase the separation between the equipment and receiver.
- Connect the equipment into an outlet on a circuit different from that to which the receiver is connected.
- Consult the dealer or an experienced radio/TV technician for help.

FCC Caution

Any changes or modifications not expressly approved by the party responsible for compliance could void the user's authority to operate this equipment.

This device complies with Part 15 of the FCC Rules. Operation is subject to the following two conditions:

- 1 This device may not cause harmful interference, and
- 2 This device must accept any interference received, including interference that may cause undesired operation.

FCC Radiation Exposure Statement:

This equipment complies with FCC radiation exposure limits set forth for an uncontrolled environment. The highest SAR value as reported to the authorities for the CFVII 50C SE 50YOM when tested for use by the Body is 0.27 W/kg and Extremity is 0.301W/kg against a limit of 1.6W/kg.

3.5 ISED

RSS-Gen Information for the Certification of Radio Apparatus
This device complies with ISED licence-exempt RSS standard(s). Operation is subject to the following two conditions:

- 1 This device may not cause interference, and
- 2 This device must accept any interference, including interference that may cause undesired operation of the device.

Cet appareil est conforme au(x) standard(s) RSS exempt(s) de licence de ISED. Son fonctionnement est sujet aux deux conditions suivantes:

- 1 cet appareil ne doit pas occasionner d'interférence
- 2 cet appareil doit supporter toutes les interférences, y compris celles qui pourraient provoquer un mauvais fonctionnement de cet appareil.

RSS-102 RF Exposure Compliance of Radiocommunication

Apparatus

The CFVII 50C SE 50YOM has been designed to comply with safety requirements for exposure to radio waves. SAR testing has been performed in accordance with RSS-102, with the CFVII 50C SE 50YOM transmitting at its highest certified power level in all used frequency bands. The highest Body SAR value for the CFVII 50C SE 50YOM when tested was 0.27 W/kg against a limit of 1.6 W/kg. Extremity SAR was measured to 0.301 W/kg.

Please follow the instructions included in the user guide for product installation and use.

Le CFVII 50C SE 50YOM a été conçu pour se conformer aux exigences de sécurité en matière d'exposition aux ondes radio.

Des tests SAR ont été effectués conformément à la RSS-102 avec le CFVII 50C SE 50YOM transmettant à son plus haut niveau de puissance certifié dans toutes les bandes de fréquences utilisées.

La valeur SAR la plus élevée pour la CFVII 50C SE 50YOM lors des tests était de 0,27 W/Kg contre une limite de 1.6 W/kg. On a mesuré l'extrémité SAR à 0,301 W/kg.

Merci de suivre les instructions fournies dans le mode d'emploi pour l'installation et l'utilisation du produit.

4.1 PARTS, COMPONENTS, BUTTONS AND CONTROLS

All parts and function mentioned in this Chapter, are described in further detail in other specific sections.



1 **Menu button**

This button opens the main menu. If the main menu is already active, the control screen is shown.

2 **Cross button**

Function depends on screen information. The button acts as delete image button in browse mode. The button moves the selector up in menus. In control screen it used for parameter selection.

3 **Star button**

In browse mode this button is used to rate images. See page 69. If image rating is turned off in the settings (page 81), the star button will zoom out to 9-view. In live view the star button will zoom in to for precise focusing. It is also used as a select button when controlling camera settings using buttons.

4 **Display button**

Function depends on screen information. The button changes the overlay in live view mode. In menus, it moves the selector down. When the control screen is active, it is used for parameter selection.

5 **On/Off and browse button**

A long-press (press and hold for one second) will turn On or Off the camera depending on the previous state. A short-press activates the display and shows the last captured image.

6 **Status LED**

Green color: indicates that the camera is ready to make a capture.

Yellow colour: The camera is busy and not ready to make a capture.

Red color: Error state

Blinking: The image is written to the card or host computer.

7 **Touch display**

Multi-touch display with full touch support to control all settings of the camera as well as panning, pinch and spread zoom for image review. The display can be tilted up to 90 degrees upwards.

Note!

You can force the CFV into standby mode to save power by pressing and holding the Menu button and making a short-press on the On/Off button.

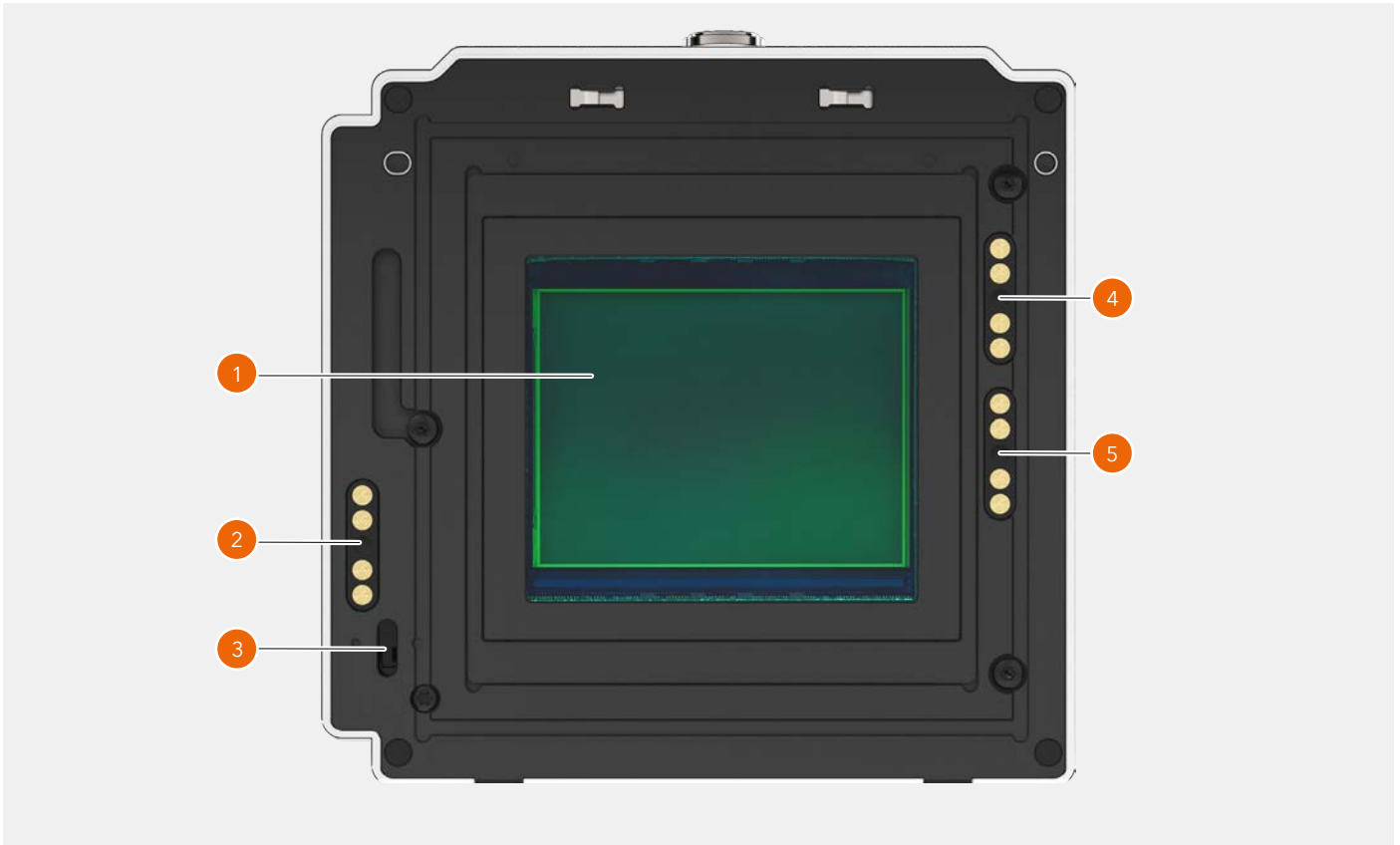

1 Sensor

Please make sure to read the cleaning instructions in the Appendix on page 116.

2 Contact for 200 Series cameras

Electrical contact used with modified 200 Series cameras.

3 Release bar sensor

Used to synchronize exposure with the 500, EL, SWC, unmodified 200 and 2000 type cameras.

4 907X Contact

Contact used with the 907X camera body.

5 555 ELD Contact

Contact used with the 555 ELD camera.



1 Lock button

Make sure that you hold the back securely and slide the Lock button to the right to release it from the camera.

2 Speaker

Openings for audio signals.

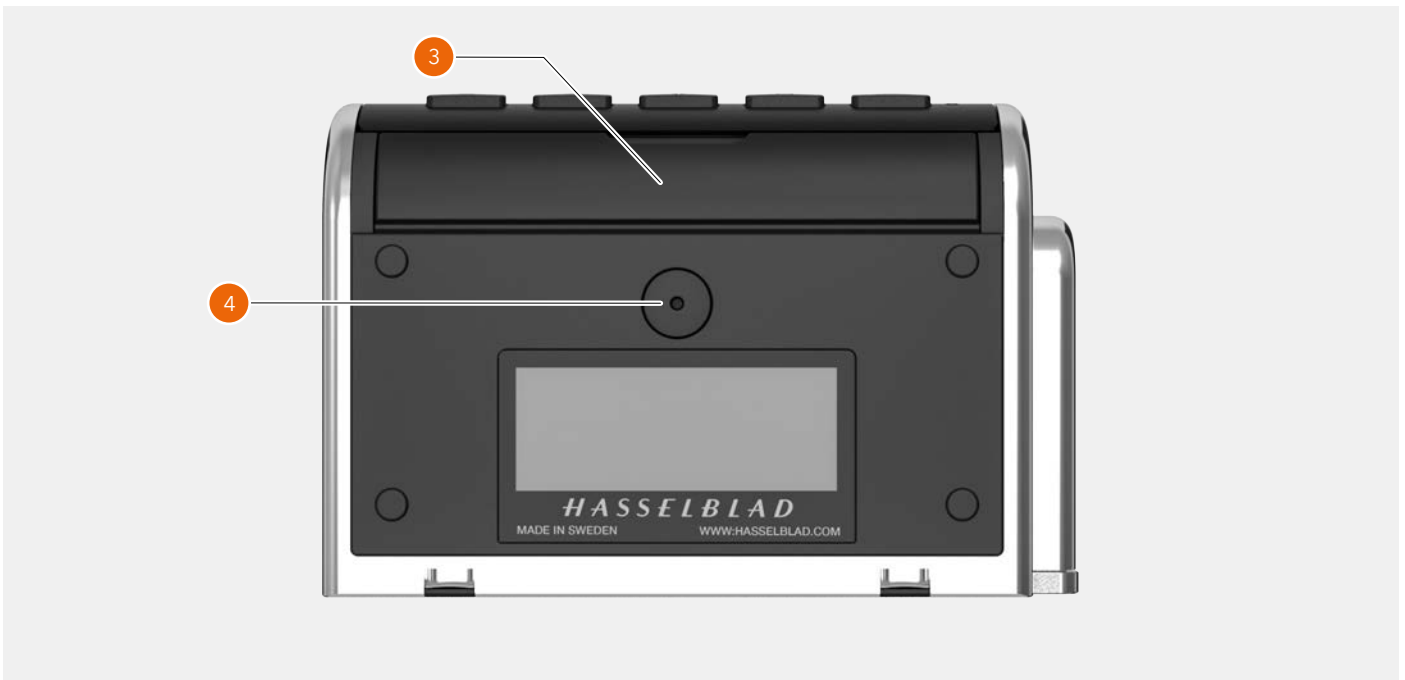

3 Lid for connector ports

Protective lid for connector ports for audio and sync cables.

4 DC power input

Plug for external DC power input.

Spec: 12-24 VDC/35W.

Plug: 3.7/1.3 mm. Positive voltage on center pin. Make sure polarity is correct not to damage the camera.

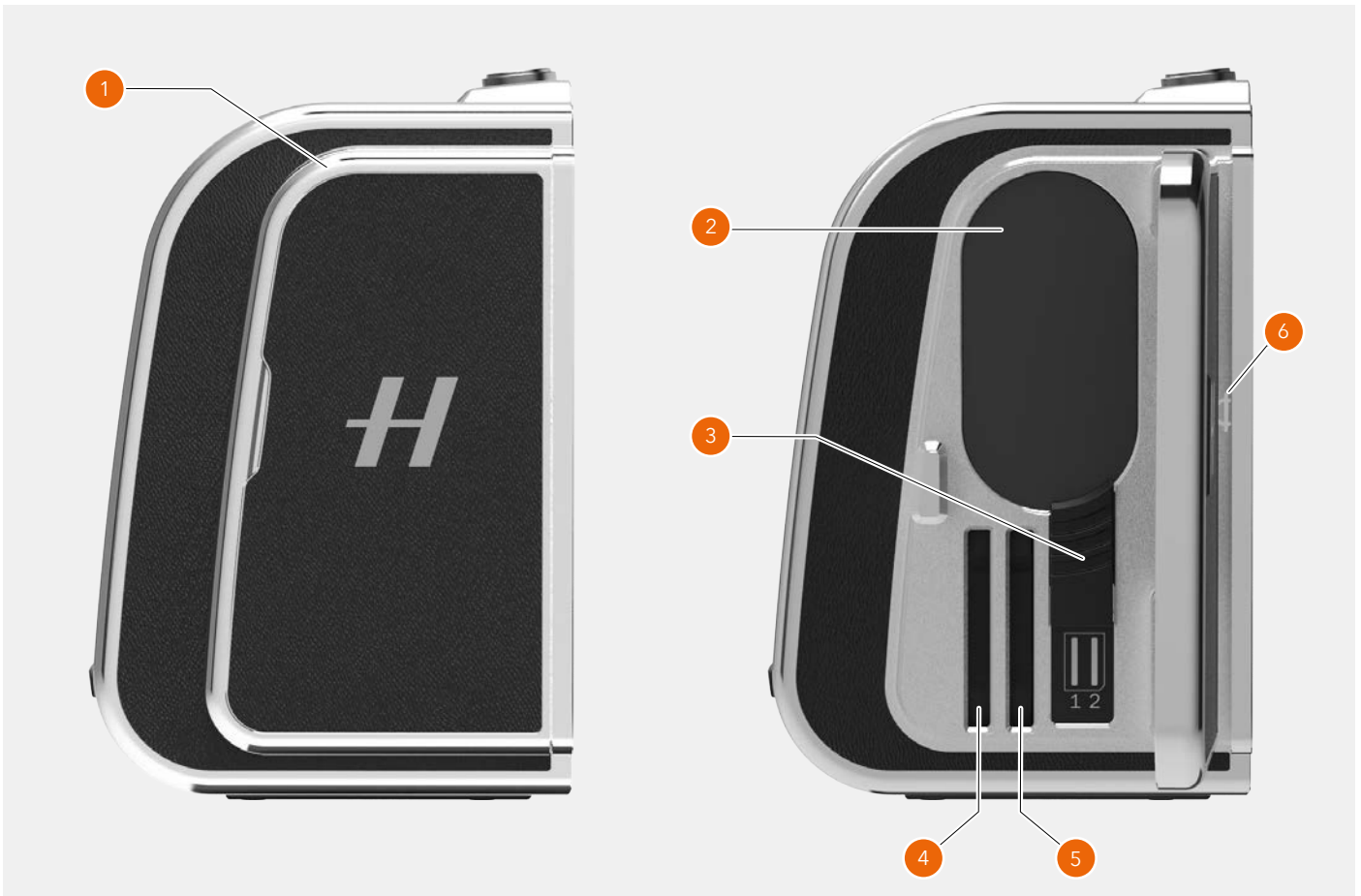

- 1 **Lid**
Lid for battery and SD memory cards.
- 2 **Battery**
Rechargeable battery.
- 3 **Battery release**
Slide the release down to remove the battery.
- 4 **SD Card 1**
Slot for SD card number 1.
- 5 **SD Card 2**
Slot for SD card number 2.
- 6 **Image plane index**
Indicates the exact location of the image plane. Not visible when the lid is closed.

4.2 PORTS AND CONNECTIONS

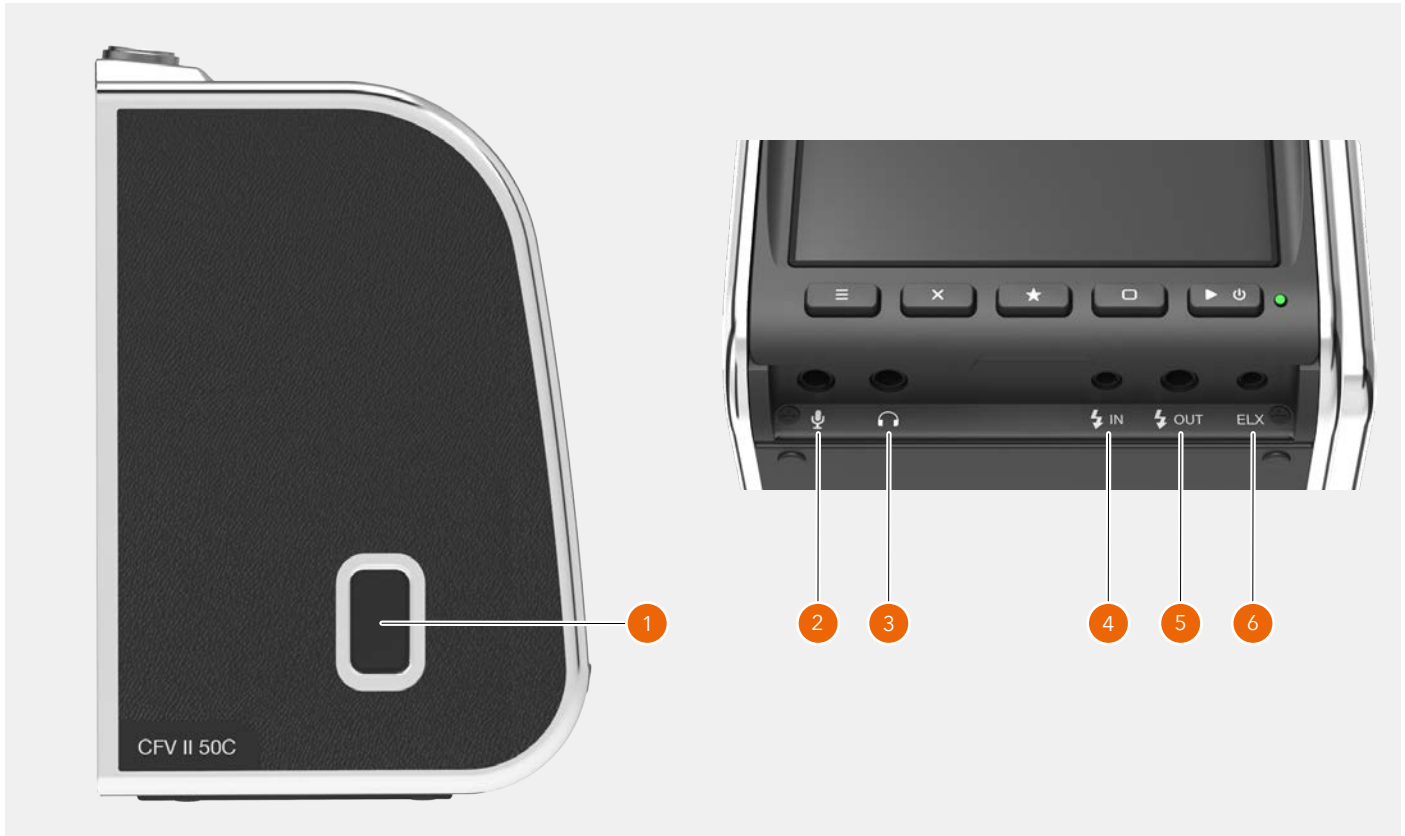

- 1 **USB port**
USB-3 type C for connection to a host computer or iPad Pro.
- 2 **Microphone**
3.5mm stereo input for an external microphone.
- 3 **Headphone**
3.5mm stereo output for headphones.

- 4 **Flash sync input**
For synchronization with mechanical shutters. Use the supplied flash sync input cable.
- 5 **Flash sync output**
For connection of external flashes. Use the supplied flash sync output cable.
- 6 **ELX output**
Connection to an EL-type camera or the Winder CW. Enables exposure remote control from Phocus. See page 113 for connection cables.

4.3 DISPLAY AND SCREENS

TOUCH

The display of the CFV is touch sensitive and you can use it in the same way as a smartphone. For example Swipe, Tap, Pinch and Spread to Zoom. You can also navigate by using the 5 buttons. This is further explained starting at page 40.

TILT DISPLAY

The display can be tilted 90 degrees up for convenient operation in many situations. E.g. when shooting from a low camera angle. To tilt the display, insert a finger in the groove at the bottom of the display and tilt the display upwards. There are click-stops for 45 and 90 degrees, but any angle in between can be used.

Note!

Always remember to fold the screen to normal position before transporting the camera.



AVAILABLE SCREENS

The CFV can show the following type of screens:

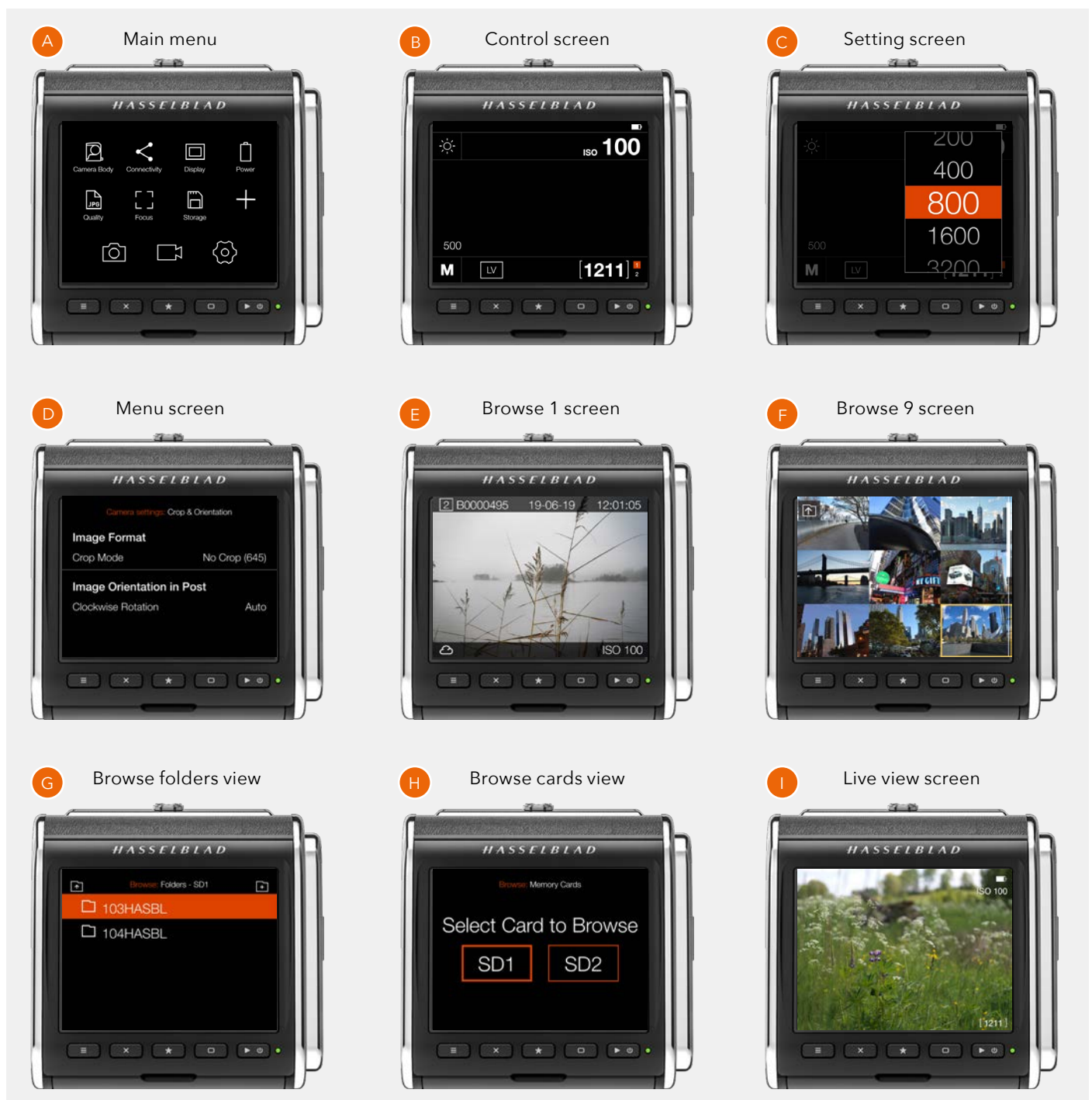

- **Main menu (A)**
Menu- and Short-cut icons.
- **Control screen (B)**
Status Screen.
- **Setting (C)**
Sample setting screen.
- **Menu (D)**
Sample menu screen.
- **Browse image (1-view) (E)**
Preview screen, one image.
- **Browse images (9-view) (F)**
Preview screen, 9 images.
- **Browse folders View (G)**
Select folder on card to browse.
- **Browse cards View (H)**
Select card to browse.
- **Live view (I)**
Continuously updated Live View.



MAIN MENU SCREEN

This screen contains an area for 8 short-cut icons **(A)** which are a fast way to access the most used functions and settings. They can easily be customized and re-arranged.

At the bottom of this screen there are three menu icons **(B)**. When any of them is tapped, the corresponding menu system will be shown. From left they are:

- Camera Settings **(C)** 
- Video Settings **(D)** 
- General Settings **(E)** 

The menus can also be directly accessed by using the button indicated above.

The complete menu system is described starting on page 28.

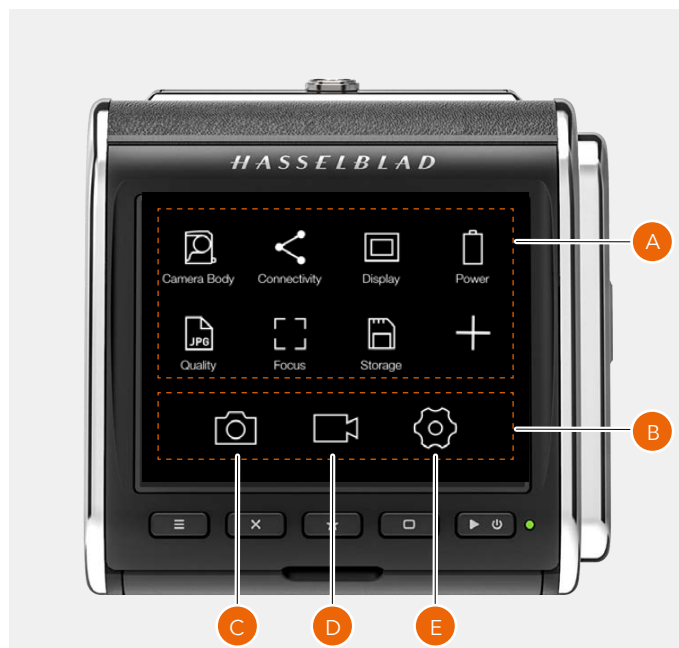

TO USE THE SHORT-CUTS

The short-cuts are a quick and easy way to go directly to the corresponding setting in the menu. Tap the icon matching the function or setting required to go directly to that setting. Adding the short-cuts you use most often will save time when using the CFV.

ADD SHORT-CUT

If the required setting is not available on the screen, simply tap the + icon to bring up a list of additional short-cuts **(F)**. This list contains items not already added to the Main Menu. Select any from this list by tapping and the + sign will be replaced with the new short-cut.

If there are already 8 short-cuts you will have to delete one to be able to add another.

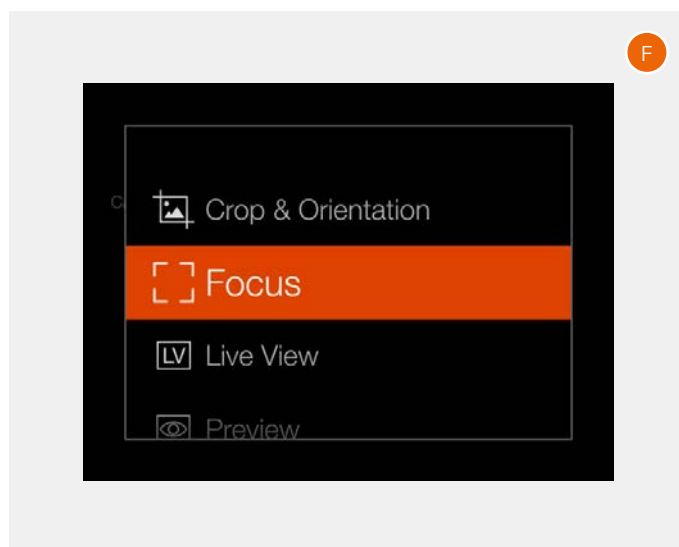

DELETE A SHORT-CUT

To delete a short-cut, press and hold it for one second. A small X icon  appears next to the short-cut **(G)**. Tap the X icon to delete the short-cut.

RE-ARRANGE SHORT-CUTS

To move a short-cut icon to another location on the screen, press and hold for one second. Move the icon to a new location. The other icons will automatically move and re-arrange.



CONTROL SCREEN

This is a status screen showing the actual settings of the CFV. From this screen, you can change settings directly or activate Live View.

The control screen can be activated in two ways:

- Form any screen, you can slide in the control screen by swiping the display from the top.
- Press the Menu button until the control screen is shown (requires 1 or 2 clicks).

From the control screen you can change the following settings:

- White balance (**A**)
- ISO (**B**)

Start Live View:

- Tap the LV icon (**F**). Note that the camera must be prepared for live view. See details starting on page 51.

Change settings using touch

Tap the value to bring up a setting dialogue (**K**) ISO and White Balance (**L**).

Change settings using buttons

Press the Rectangle Button (**H**) or the Cross button (**G**) to highlight the setting. Press the Star button to bring up the setting dialogue. If LV (**F**) is highlighted, live view will start.

The control screen also contain the following status indications:

- Battery status with option percent value (**C**).
- Exposure mode (Manual) (**E**)
- Camera body type (**D**)
- Remaining images on card (free space) (**G**)
- Card status (**J**)

When the camera body is set to Any (Electronic Shutter), there are additional options on the control screen. See more on page 59.

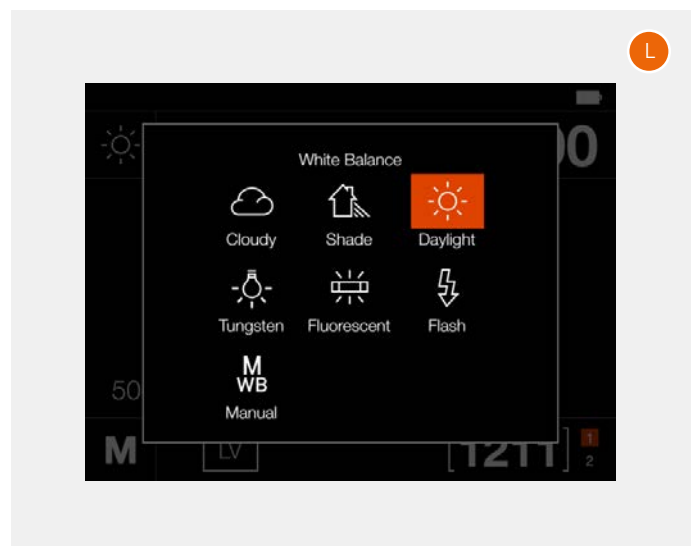
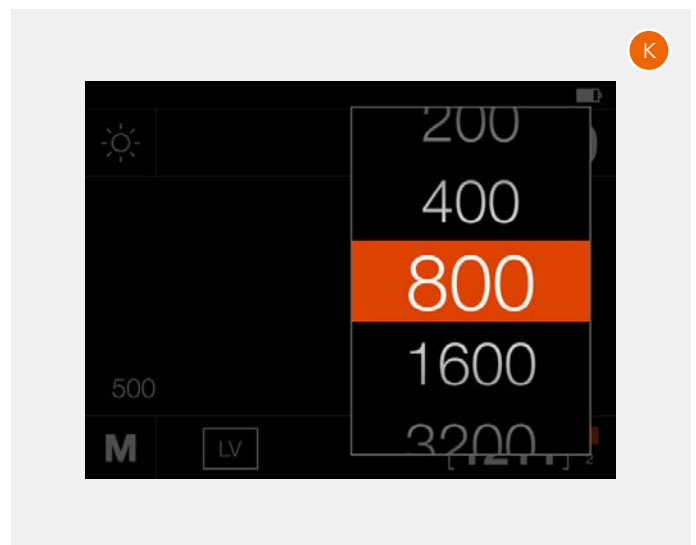
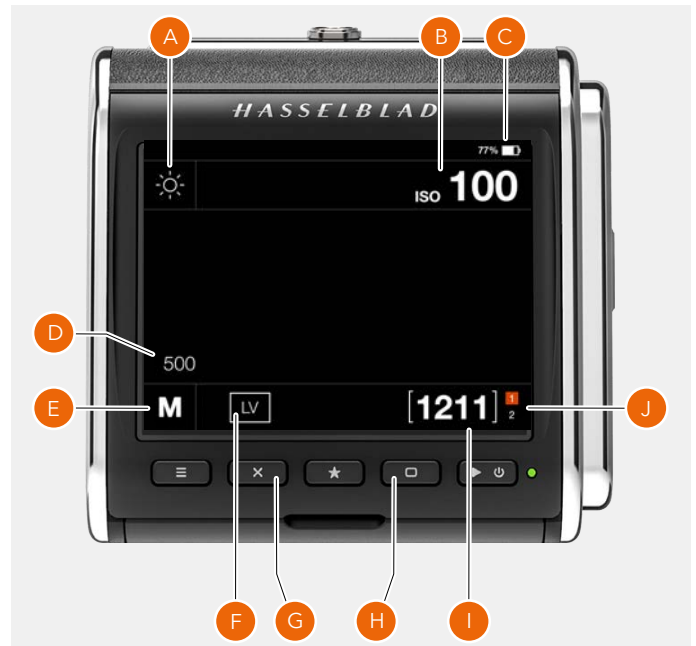

MENU SCREEN NAVIGATION

All settings of the CFV are available in the menu system which is entered by tapping one of the icons at the bottom of the screens as described on page 33.

You can use the menu system either by using touch or by using the buttons as described on the next page.

Using Touch

- Tap the camera settings icon **(A)**.
- The menu screen for camera settings appears **(B)**.
- Tap Camera Body **(C)**.
- The camera body settings screen appears **(D)**.
- Tap the value to the right (**500**) to show the settings screen **(E)**.
- Select the desired camera body by swiping the list **(F)**.
- The display will return to the main menu screen **(A)**.
- To exit without saving the setting, press the menu button **(G)**.



Using buttons

Three buttons are used for menu navigation: Cross button **(B)**, Star button **(G)** and Rectangle button **(E)**. The Rectangle button moves the selection down and the Cross button moves up. The Star button enters the selection.

- Press the Menu button **(A)** to show the main menu **(C)**.
- Press the Cross button **(B)** to enter the camera settings menu **(D)**.
- Press the Rectangle button **(E)** to highlight the top item **(D)**.
- Press the Star button **(F)** to enter the Camera Body settings.
- Press the Rectangle button **(G)** to highlight the top item **(H)**. Press the Star button **(I)** to enter the setting **(J)**.
- Use the Rectangle button **(K)** to move the selection down and the Cross button **(M)** to move up. When the correct camera type is selected, press the Star button **(L)** to make the selection.



BROWSING IMAGES

One-view

You can preview images on the active memory card by clicking the Play/On-Off button **(B)**. The last captured image will be shown. To view other images swipe horizontally on the screen **(C)**.

Nine-view

If you pinch-zoom **(D)** (move two fingers together on the screen) or press the Star Button **(E)**, nine images will be shown at the same time. To view another image, just tap the small thumbnail. If you have many images on the card, you can swipe vertically to view the rest **(F)**.



BROWSE OVERLAYS

In one-view, you can change overlay with different information by pressing the Rectangle button **(8)**. The following options are available:

- Standard **(A)**.
- Full screen **(B)**.
- Detailed info **(C)**.
- Luminance histogram **(D)**.
- Separate histogram **(E)**.

Information on the screen:

- Active card **(1)**.
- Image name **(2)**.
- White balance **(3)**.
- Measured shutter speed **(4)** See
- ISO **(5)**.
- Capture time **(6)**.
- Capture date **(7)**
- Image rating **(9)**.



5.1 INTRODUCTION

This section will cover the basic operation with all compatible camera models. For detailed information of each camera model, you can find user manuals for most older V System cameras in the downloads section of the Hasselblad website www.hasselblad.com.

5.2 BASIC SETTINGS

ISO

The ISO value (sensitivity) can be set from the control screen or the Live View screen. From the control screen you can use both touch and buttons. From the Live View screen, only touch is possible.

Set ISO From the control screen by touch:

If the control screen is not already visible you can slide the finger from the top to the bottom to reveal it. This can be done from any screen. See also page 19. Alternatively press the menu button **(B)** until you see the control screen **(A)**.

Tap the ISO value to bring out the setting list **(C)**. Select the new ISO value from the list. Slide up/down if the new value is not visible. Tap the new value and the list will disappear and the new value will be selected **(D)**.

Note!

ISO and white balance can also be set directly from the live view screen. See page 42.

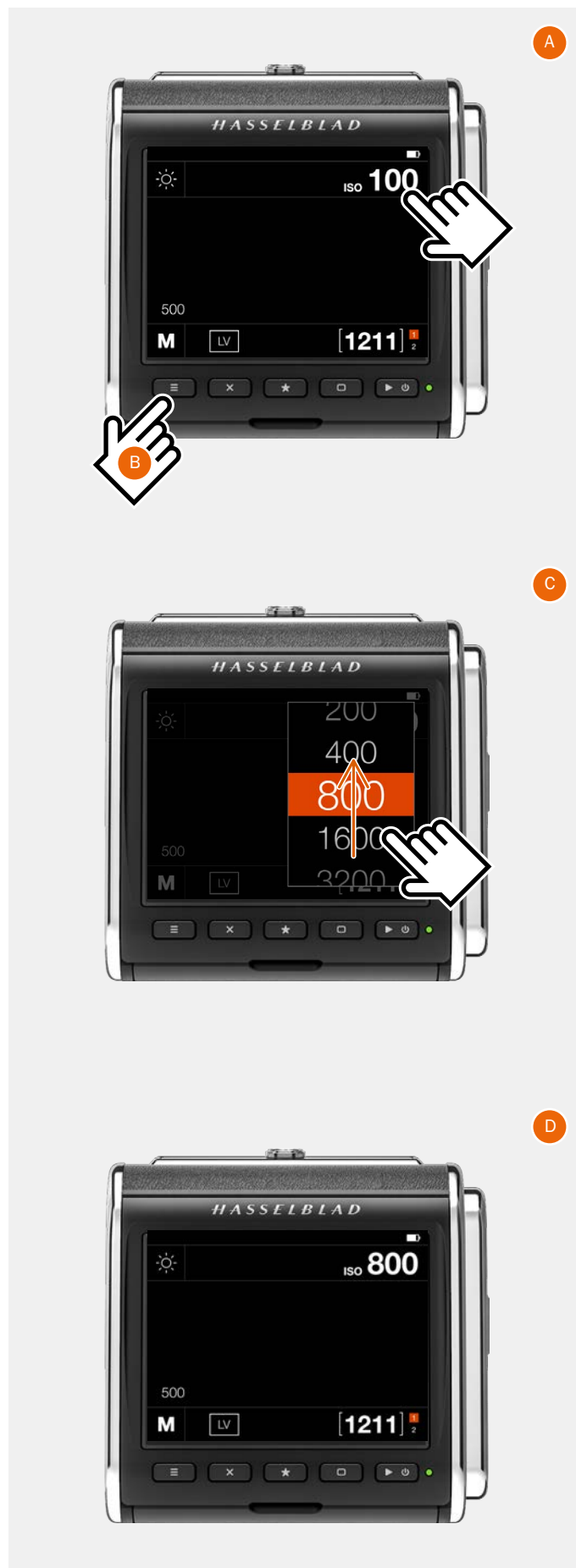

Set ISO by using buttons:

Press either the rectangle or cross button until the ISO value is highlighted in orange color **(A)**.

Press the Star button to bring up the list **(B)**.

Press the Rectangle button to select a higher ISO value and the Cross button to select a lower value **(C)**.

Finally press the Star button to store the selected new value **(D)**.



WHITE BALANCE

- Auto white balance AWB.
- Cloudy.
- Shade.
- Daylight.
- Tungsten.
- Fluorescent.
- Flash.
- Manual white balance MWB.
- Picker (select white balance from image).

Change white balance preset by touch:

On the control screen, tap the white balance icon (A). This brings up the white balance setting screen (B). Tap one of the white balance presets to select it (C). The right frame of the screen (D) will show the values for Temperature and Tint associated with the selected white balance. Tap the white balance icon again to select and return to the control screen.

Setting manual white balance values

From white balance setting screen (B), change value for Temperature or Tint by tapping in the right frame (D). Tap the value (E) to change and select a new value from the list (F).

Tap the left arrow (G) to return to the white balance setting screen (B). Finally, tap the manual white balance icon again to select it and return to the control screen (H). White balance has now been set to Manual mode.

	Temp [°K]	Tint
Cloudy	6500	10
Shade	7500	10
Daylight	5500	10
Tungsten	2850	0
Fluorescent	3800	21
Flash	5500	0
Manual	Variable 2000 to 10000	Variable -100 to 100

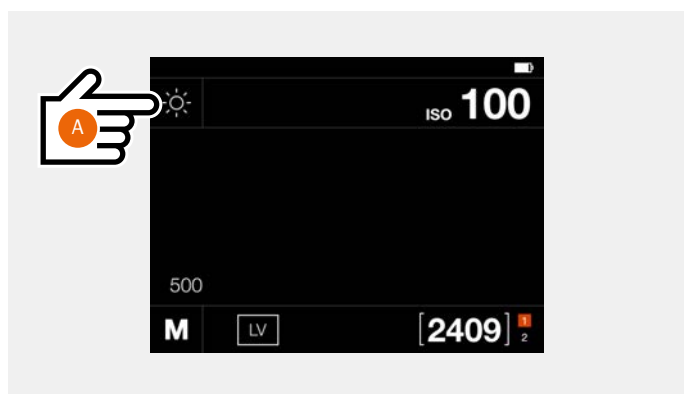
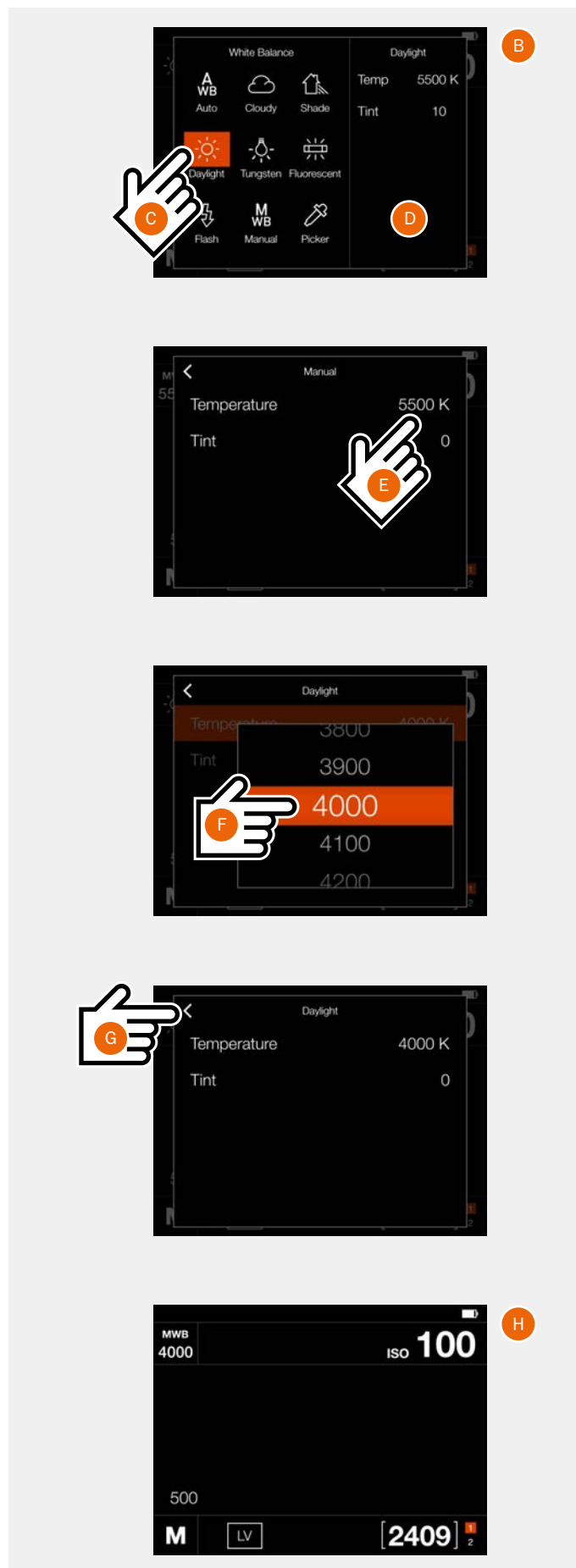

Set WB by using buttons:

Press either the rectangle or cross button until the WB icon is highlighted in orange color **(A)**.

Press the Star button to bring up the list **(B)**.

Press the Rectangle button to move the selection to the right and the Cross button to move it to the left **(C)**.

Finally press the Star button to store the selected new setting **(D)**.

Note!

Value for Temp and Tint for Manual White Balance cannot be set using buttons.



Set White balance from image (Picker)

Tap the white balance icon on the control screen to bring up the settings screen. Tap the Picker icon (A).

The screen will show the last captured image with a white balance picker tool (B).

If the center of the image is not neutral, move the picker tool by touching anywhere inside the circle (1) and sliding so that the measuring area (2) falls over a neutral area (C). The status bar will show the actual values for Temp and Tint. To accept these values, press the rectangle button (5). To exit without saving the values, press the cross button (4).

The control screen will now show the new value for Temp (D) and it will be used together with Tint for following images.

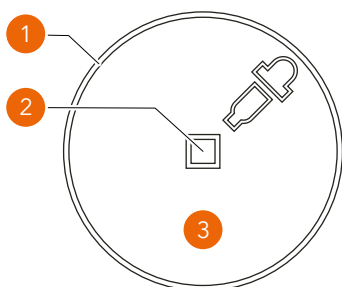

- 1 Active area for moving the tool by touch.
- 2 Active area for calculating Temperature and Tint.

Note!

You can change to another image by swiping the image outside of the picker tool area.

Note!

You can fine-tune the position by tapping inside the circle. E.g., if you tap at point (3), the picker will move a small increment down.

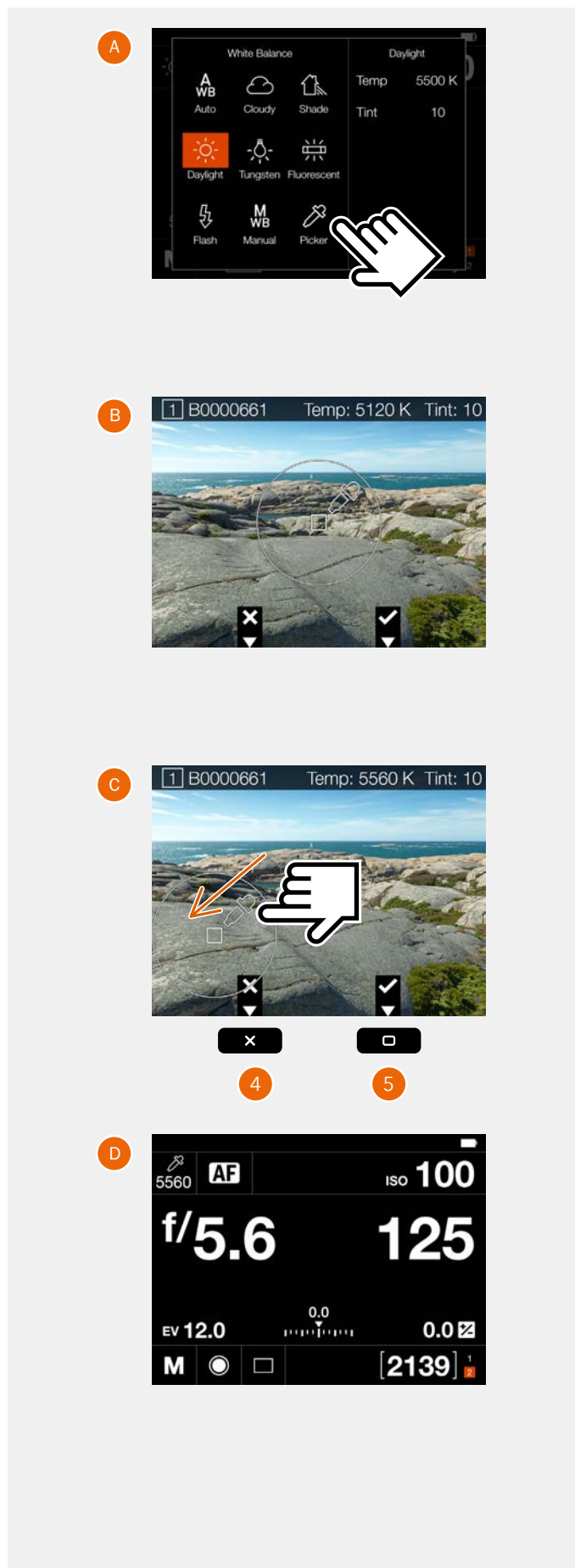

5.3 LIVE VIEW

The live view function in the CFV allows you to preview the final image. It can be used for composition but also for critical focusing.

In order to fully utilize the resolution and quality of the high resolution sensor, exact focusing is a must and in most cases the focusing accuracy achieved by using the focusing screen only may not be good enough. Especially not when using the lens full open.

When using live view, the camera must be “open” in order for the sensor to see through the lens. How to set up the camera like this, depends on which camera is used. Please see the exact setting for the specific camera model starting on page 51.

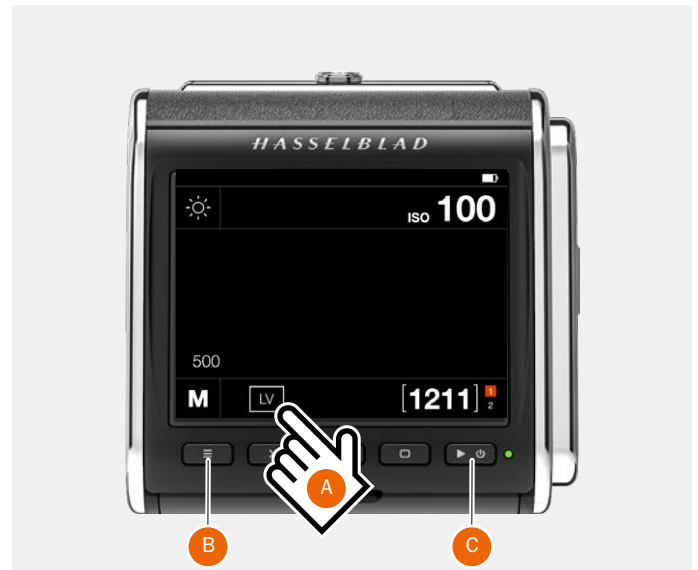

START LIVE VIEW

From the control screen:

- Click the live view icon **(A)** and live view will start. To stop live view, press the Menu button or the Play/On-Off Button.

STOP LIVE VIEW

- Press the Menu button **(B)** or the Play/On-Off button **(C)**.

Note!

It is only possible to capture an image directly from live view when camera body is set to Any (Electronic Shutter).

Note!

Prolonged use of live view will drain the battery and make the CFV quite warm.

Continued on the next page.



5.4 LIVE VIEW OVERLAYS

When live view is active, you can select different overlays by clicking the Rectangle button .

The following overlays are available:

- 1 **Standard (A)**
Contain status icons for battery level, ISO value, remaining captures, card status and Wi-Fi status.
- 2 **Grid (B)**
Same as standard but with an added 1/3 grid.
- 3 **Spirit level (C)**
Same as standard but with an added spirit level. See page 95.
- 4 **No Overlay (D)**
Clean view with no icons.

The selected overlay will be saved and used the next time Live View is activated.

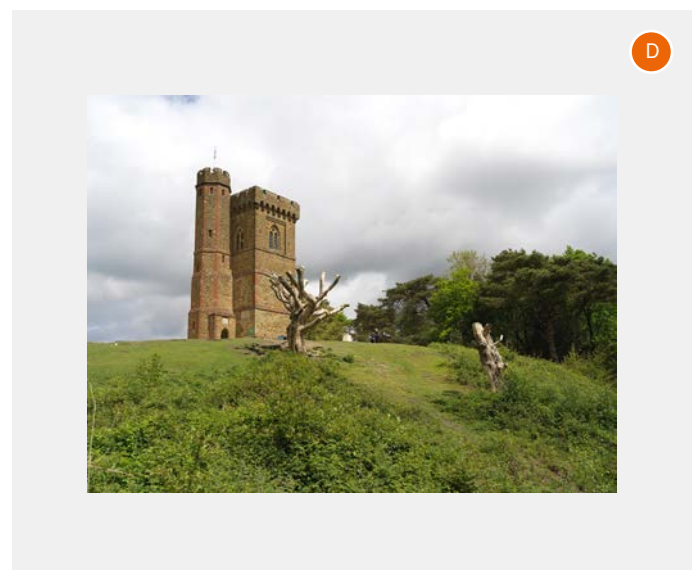
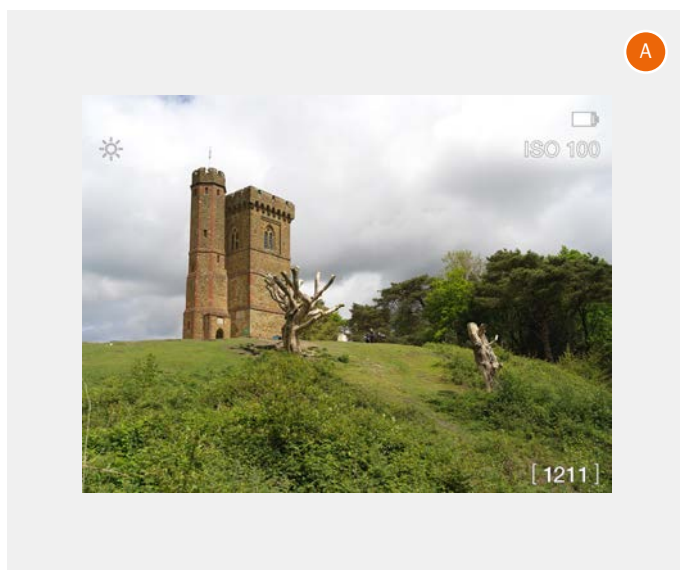
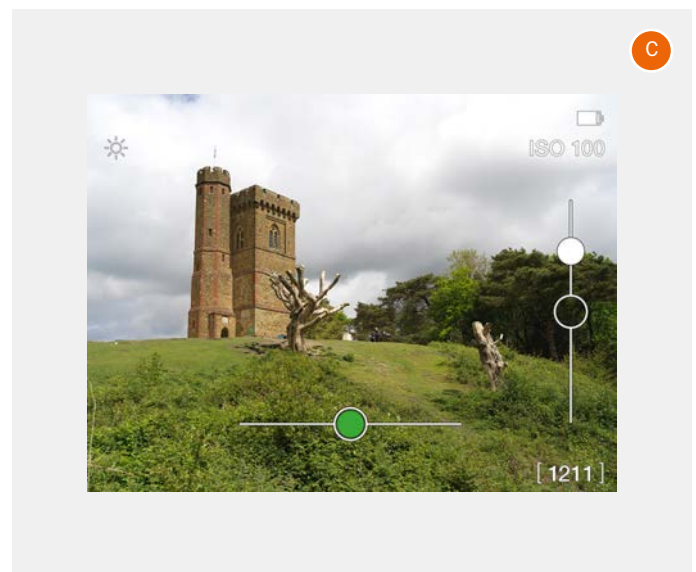
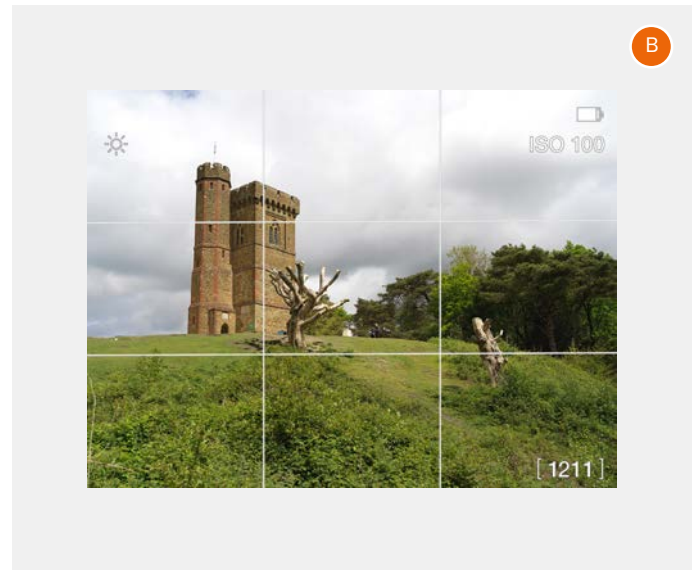

5.5 LIVE VIEW SETTINGS

From the live view screens **(A)** and **(C)** where ISO and white balance is shown, it is possible to directly set new values.

ISO

From the live view screen, tap the ISO **(1)** value to change. Select a new value from the list **(B)**.

White Balance

From the live view screen, tap the white balance icon **(2)** to change. See details on page 42 .

Even if auto white balance (AWB) is set and no icon is shown, you can still tap in the upper left corner to bring up the white balance setting screen **(D)**.

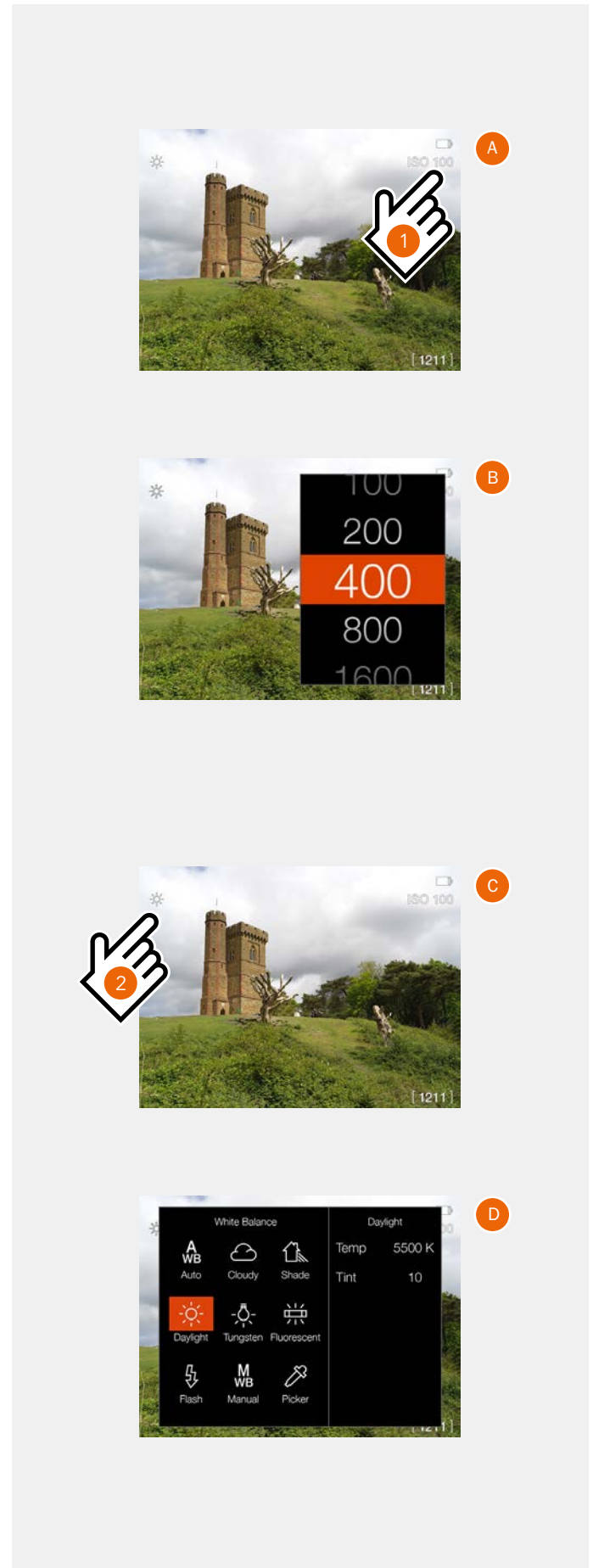

5.6 FOCUSING USING LIVE VIEW ZOOM

When live view is active, you can zoom in image for accurate focusing or for checking details. Use any of the two methods below:

- Double-tap (twice within one second) the screen **(A)**. The zoomed area will be centred around the double-tap point.
- Press the Star button **(1)**.

The image will be shown zoomed-in to 50% or 100% **(B)**. The zoom factor depends on the setting in **General Settings > Live View**.

In zoomed-in mode you can pan the screen by swiping **(C)**.

Double tap the screen or press the Star button **(1)** again to zoom out.

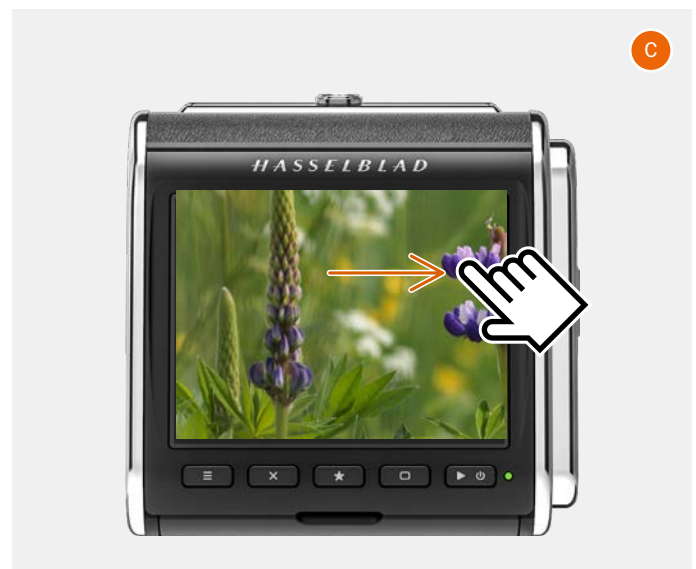
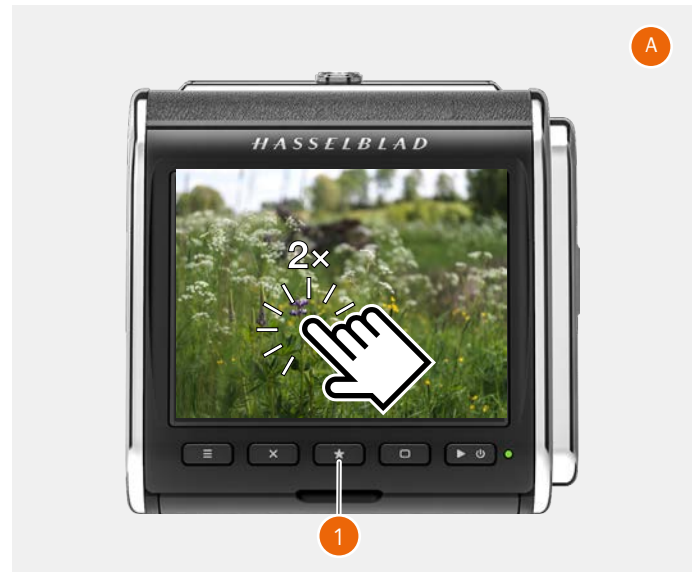

5.7 FOCUSING USING FOCUS PEAKING

In **Camera Settings > Focus**, the setting **Focus Peaking** will add an overlay on top of the live view image where sharp areas of the subject are highlighted using a selectable color. This method may not be as precise as 100% zoom-in, but in many cases be a fast way to achieve good results.

Set the camera for live view. See section starting on page 51 for details how to set the camera.

On the control screen, tap the LV icon **(B)**.

When the subject is out of focus **(C)** no color overlay is shown.

Turn the focusing ring until the main parts of the subject is highlighted in color. This indicates that the main subject parts are in focus. To check details, press the Star Button **(1)** or double-tap the screen to zoom in to 50% or 100%. Focus peaking is temporarily disabled in 50% or 100% zoom.

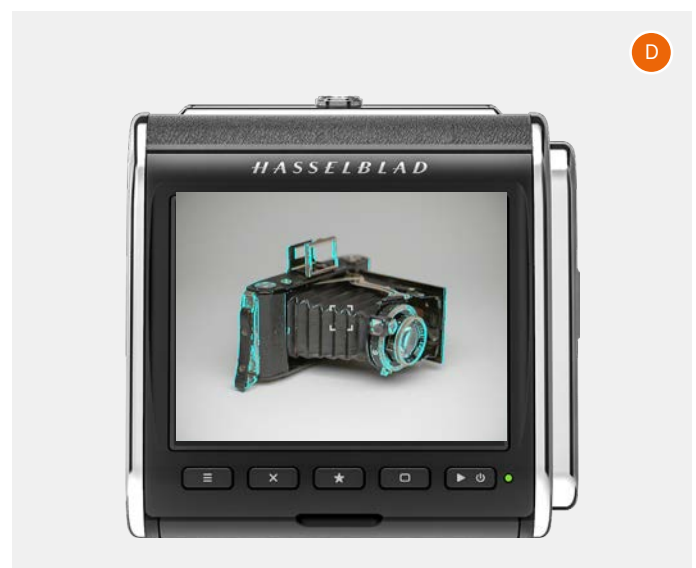
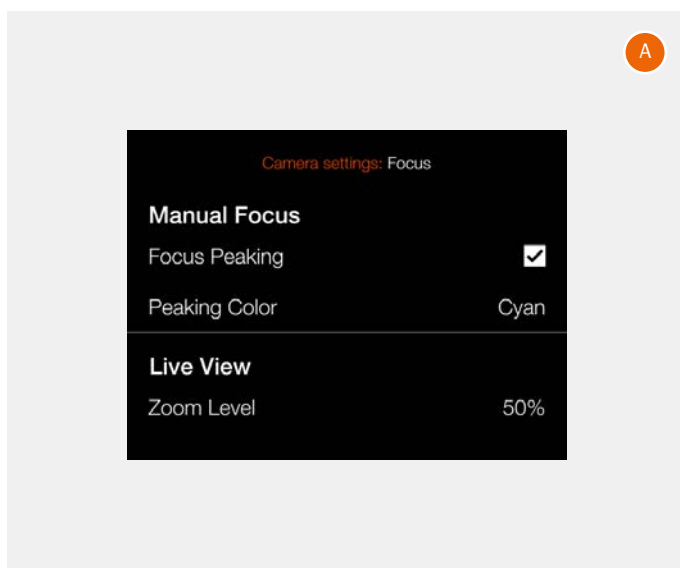
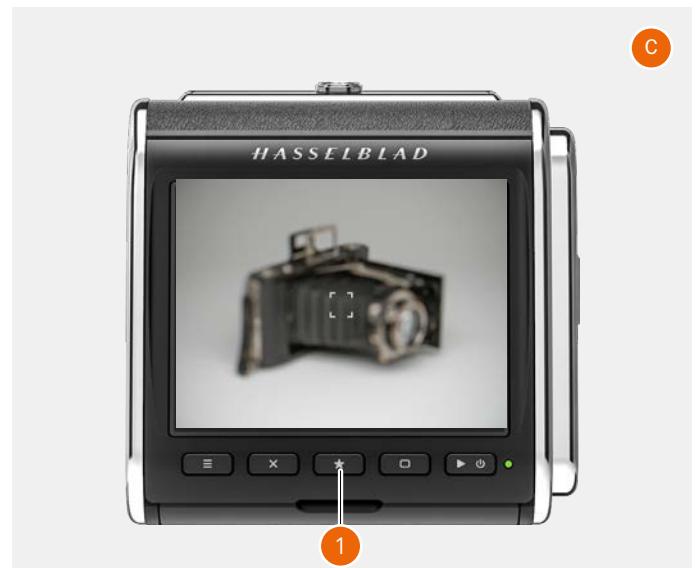
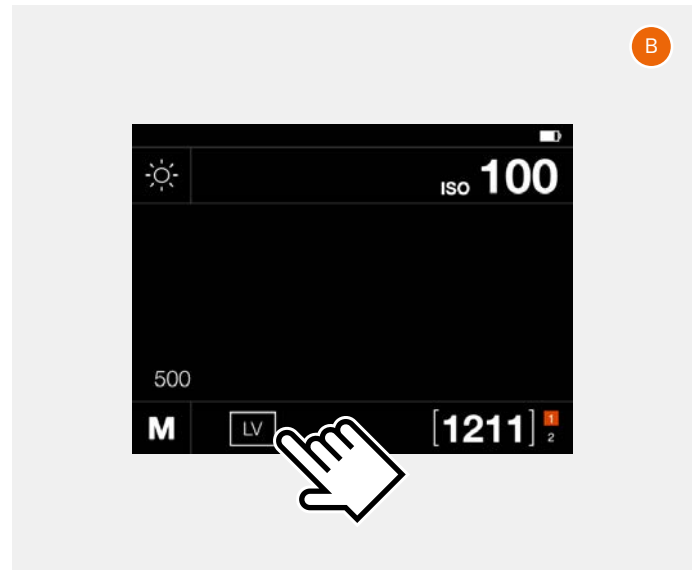

5.8 LONG EXPOSURES

The CFV II can make exposures up to 68 minutes with the camera in Bulb setting. No special setting on the CFV is required.

Controlled from camera

- Set the camera to B mode.
- Use a lockable cable release and set it to lock mode.
- Release the camera by pressing the cable release. For exposure times longer than 2 seconds, a count-up timer will be shown on the display (A).
- Open the cable release lock to finish the exposure.

Remote controlled cameras (EL-type and 503 CW with winder)

The following cameras can be remote controlled from Phocus:

- 503CW with Winder CW. See page 52.
- EL-type cameras. See page 57.

In the Phocus Camera tool (B) Shutter (C) must be set to a time equal to or longer than the desired exposure time. If the lens is set to B mode, exposure times up to 68 minutes can be controlled from Phocus.

5.9 EXPOSURE TIME IN META DATA

The CFV can measure the approximate exposure time by sensing the flash sync duration.

Using C-type lenses:

Attach the Flash sync input cable between the flash sync socket on the lens and the Flash sync input on the CFV. Camera body type should be set according to the camera type used.

Using F-type lenses:

Only modified 200 series cameras can measure the exposure time with F type lenses. Flash sync cable shall not be used. The shortest exposure time that can be measured is 1/250 s.

For exposures of 3 seconds or longer, the exposure time will be measured and saved to meta data even if the flash sync cable is not attached.

Measured exposure time is shown on the standard overlay in Browse mode (D).

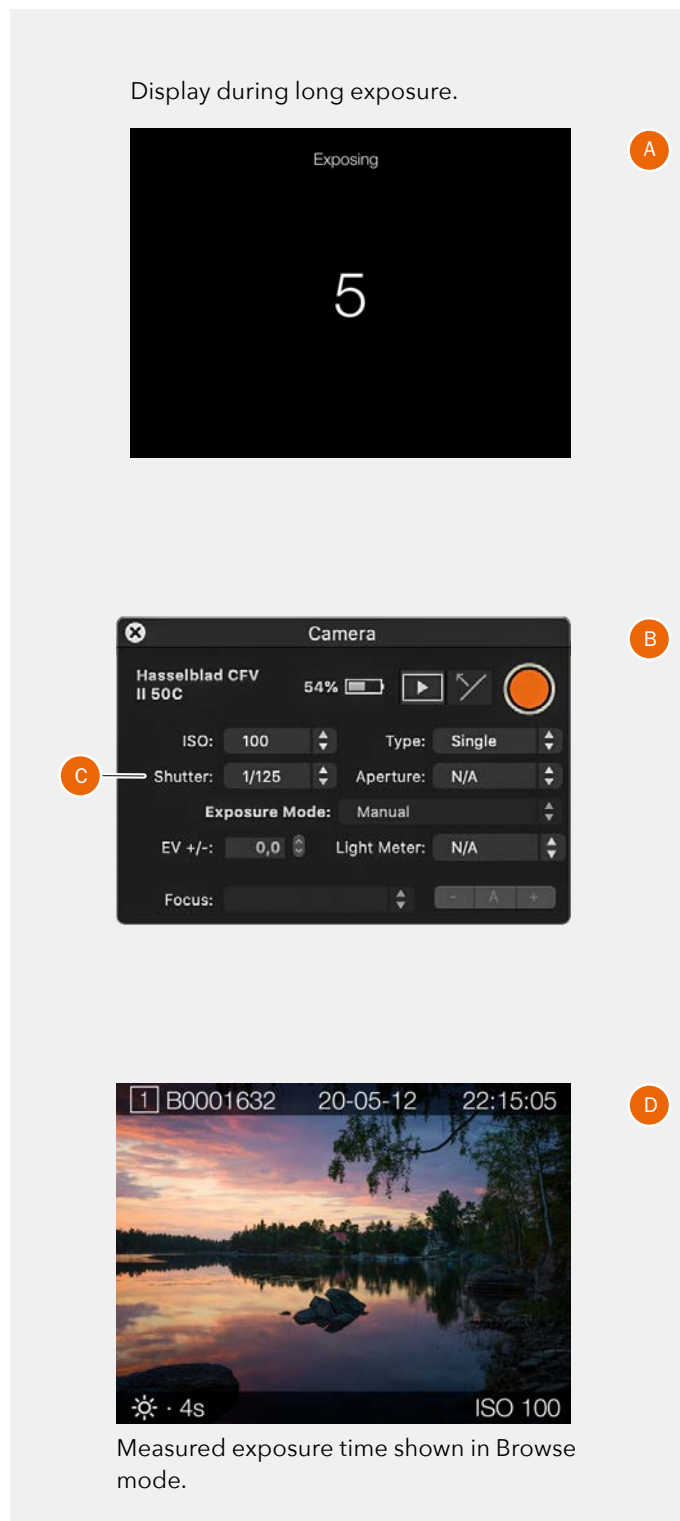

Note!

Due to tolerances on older cameras and lenses, the measured exposure time may not always be accurate.

5.10 THE CFV ON A 500 CAMERA

The 500 setting in the camera body menu (see page 73) includes the following camera models:

- 500C
- 500C/M
- 501C
- 501CM
- 503CX
- 503CXi
- 503CW
- 503CWD

The basic operation is described in the quick start chapter on page 16.

Note!

You can release the camera even if the CFV is not ready for a capture. Please make sure the status LED on the CFV is green before releasing the camera.

- Set camera body type to 500 as described on page 73.

START LIVE VIEW WITH A 500C OR 500C/M CAMERA

- 1 Set B mode on the lens.
- 2 On the 500C and 500 C/M cameras, there is a small lever (time catch) **(A)** that you can switch from 0 to T position **(B)**. This will lock the release button in the in position.
- 3 Activate live view from the Control Screen (LV).
- 4 Press the shutter release.
- 5 Press the Menu button or Play/On-Off button to end Live View.
- 6 Move the time catch back to 0 position. The camera will close again.

START LIVE VIEW WITH 501 AND 503 CAMERAS

- 1 Set B mode on the lens.
- 2 Use a lockable cable release and set it to lock mode **(C)**.
- 3 Activate live view from the Control Screen (LV).
- 4 Release the camera with the cable release.
- 5 Press the Menu Button or Play/On-Off button to end Live View.
- 6 Open the cable release lock.

Note!

When you use the Winder CW on the 503CW, the release button must be kept pressed down to keep the camera open.

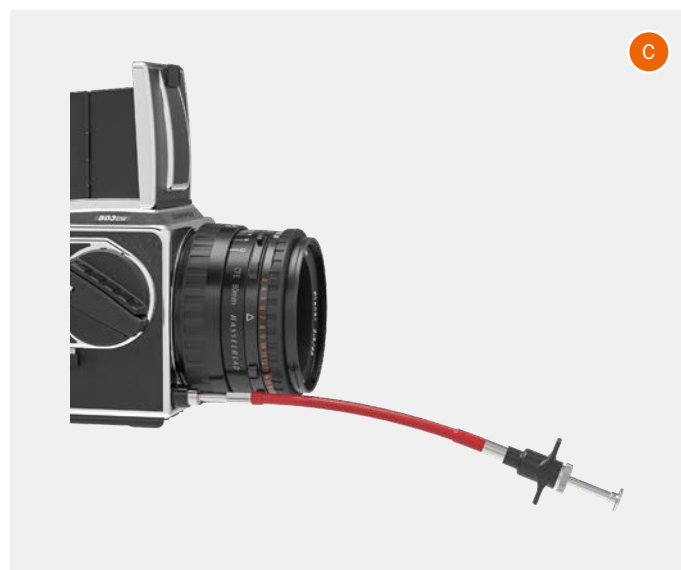
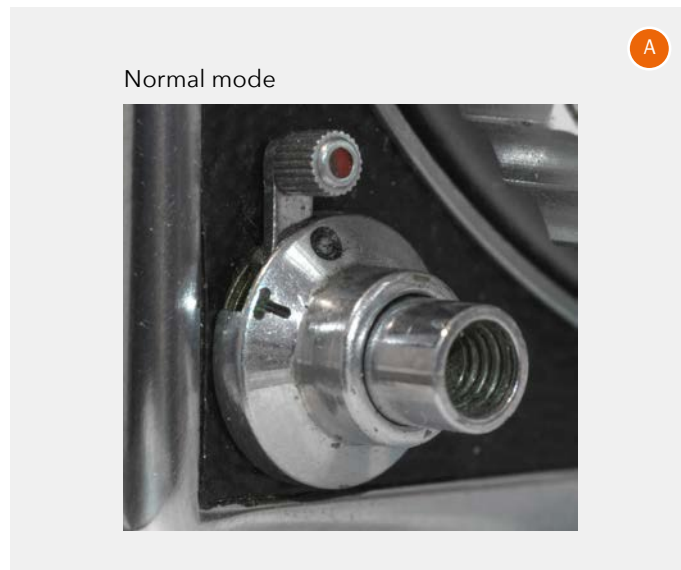

REMOTE CONTROL OF A 503CW WITH WINDER CW

When the 503CXi or 503CW camera is equipped with the Winder CW, it can be remotely released when tethered to a Mac or PC running Phocus. More information on how tethering works can be found on page 103.

Connect the exposure cable 503 **(A)** between the CFV and the socket at the bottom of the Winder CW **(C)**. The 2.5mm connector shall be connected from the ELX socket on the CFV **(B)**.

- Set camera body type to 503 + Winder CW as described on page 73.

When the camera is connected via USB to a computer running Phocus, you can release the camera from the computer. See separate phocus user guide for more details.

Note!

To use Live View, you must open the camera manually. Then Live View can be started either from the CFV Control Screen or from Phocus.



5.11 THE CFV ON A 200 OR 2000 CAMERA

Previous generations of the CFV required a small modification to the camera to work. This is no longer necessary but if you have a modified 200-camera you should use the **200 Modified** setting. Unmodified 200-cameras must use the **200** setting. A 2000-camera requires the **2000** setting.

Note!

A camera that has been modified is identified by a label on the left side as shown in **(A)**.

Note!

The camera cannot read the ISO value set on the CFV. If using any automatic mode on the camera, please set corresponding ISO value also on the camera.

Note!

You can release the camera even if the CFV is not ready for a capture. Please make sure the status LED on the CFV is green before releasing the camera.

The basic operation is described in the quick start chapter on page 16.

- Depending on your camera, set camera body type to 200 Modified, 200 or 2000 as described on page 73.

START LIVE VIEW

- 1 Set B mode on the lens. If using an F type lens, no special setting is required.
- 2 Use a lockable cable release and set it to lock mode **(B)**.
- 3 Activate live view from the Control Screen (LV).
- 4 Release the camera with the cable release.
- 5 Press the Menu Button or Play/On-Off button to end Live View.
- 6 Open the cable release lock.

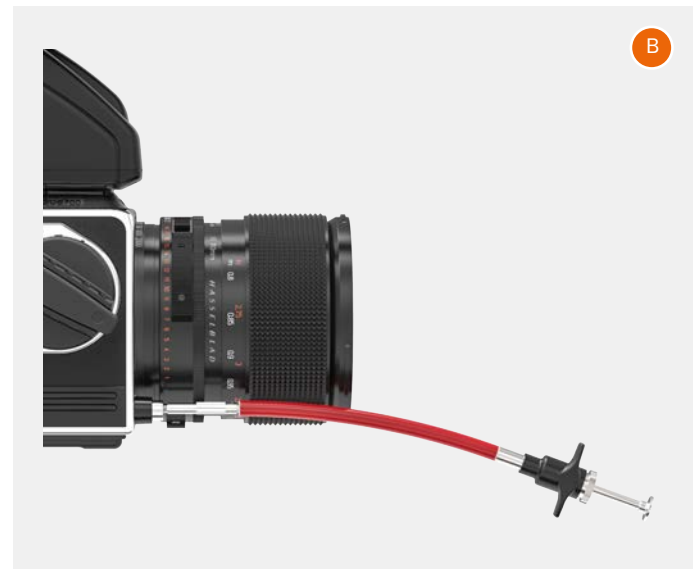

5.12 THE CFV ON AN SWC CAMERA

The SWC setting in the camera body menu (see page 73) includes the following camera models:

- SWC/M
- 903 SWC
- 905 SWC

Older versions of the SWC cameras cannot be used.

The basic operation is described in the quick start chapter on page 16.

Note!

You can release the camera even if the CFV is not ready for a capture. Please make sure the status LED on the CFV is green before releasing the camera.

- Set camera body type to SWC as described on page 73.

Note!

When you release the camera you should press firmly on the shutter release button. Pressing too slowly or stopping halfway can result in black images.

START LIVE VIEW WITH A SWC CAMERA

- 1 Set B mode on the lens.
- 2 On the SWC cameras, there is a small lever (time catch) **(A)** that you can switch from 0 to T position **(B)**. This will lock the release button in the in position.
- 3 Activate live view from the Control Screen (LV).
- 4 Press the shutter release.
- 5 Press the Menu button or Play/On-Off button to end Live View.
- 6 Move the time catch back to the 0 position.

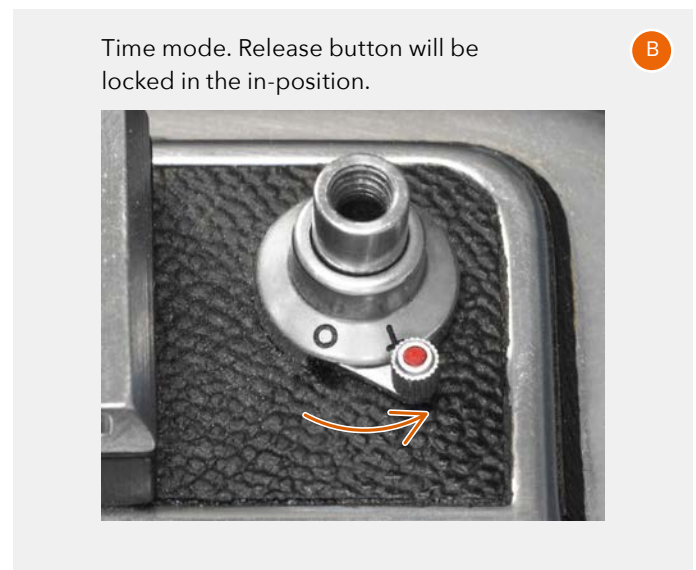
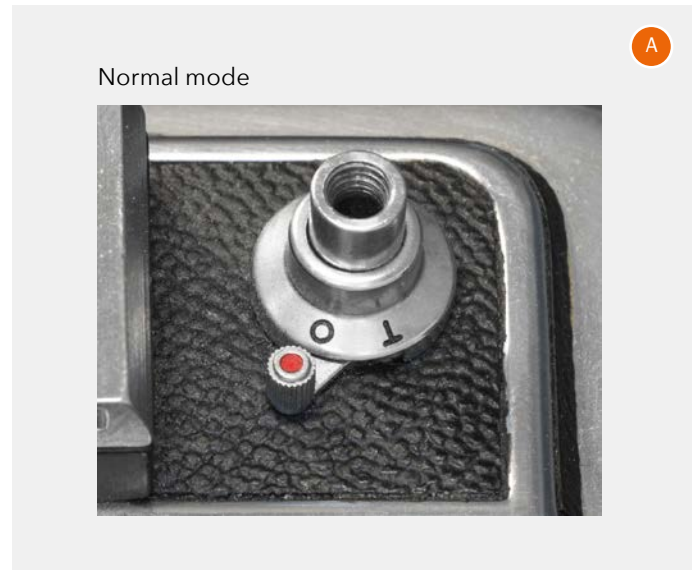

5.13 THE CFV ON AN EL TYPE CAMERA

The ELX setting in the camera body menu (see page 73) includes the following camera models:

- EL
- EL/M
- ELX

The basic operation is described in the quick start chapter on page 16.

Note!

You can release the camera even if the CFV is not ready for a capture. Please make sure the status LED on the CFV is green before releasing the camera.

- Set camera body type to ELX as described on page 73.

START LIVE VIEW WITH A EL CAMERA

- 1 Set B mode on the lens.
- 2 Activate live view from the Control Screen (LV).
- 3 Move the lock lever **(A)** from 0 to T position **(B)**. This will lock the camera open.
- 4 Press the Menu Button or Play/On-Off button to end Live View.
- 5 Move the lock lever back to the 0 position.

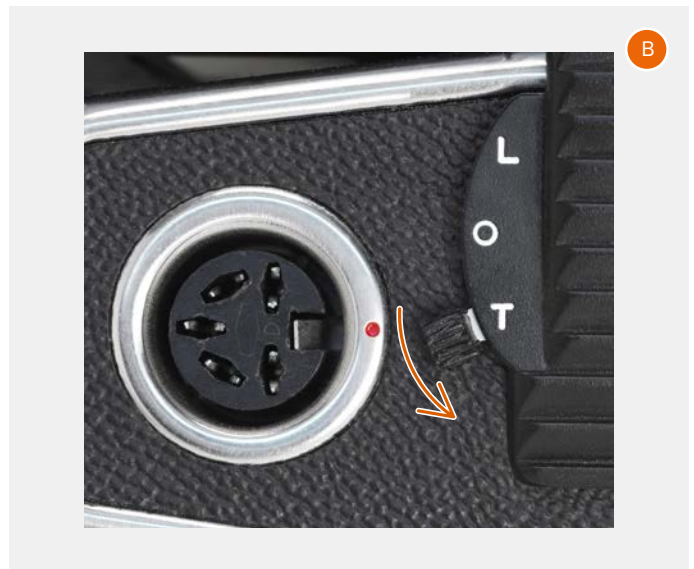
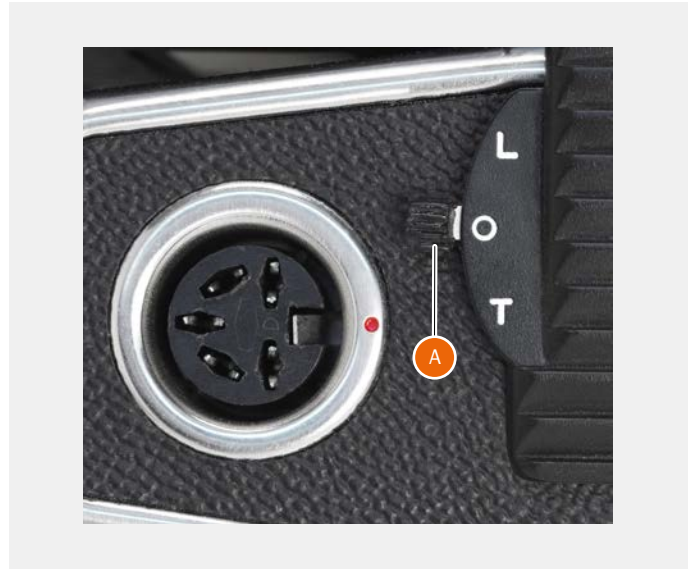

5.14 THE CFV ON AN ELD CAMERA

The ELD setting in the camera body menu (see page 73) is for the 555ELD camera only. This model has dedicated contacts to the CFV enabling the following extra features:

- Cable-free remote control from Phocus
- Exposure will be blocked if the CFV is not ready to make a capture

The basic operation is described in the quick start chapter on page 16.

When using the CFV on the ELD Camera, the release button shall be placed in the DIG input (A). This will allow the CFV to block exposure if it is not ready for a capture.

- Set camera body type to ELD as described on page 73.
- Make sure that the Release button (C) is placed in the DIG socket.

START LIVE VIEW WITH A ELD CAMERA

- 1 Set B mode on the lens.
- 2 Activate live view from the Control Screen (LV).
- 3 Move the lock lever (A) from 0 to T position (B). This will lock the camera open.
- 4 Press the Menu button or Play/On-Off button to end Live View.
- 5 Move the lock lever back to the 0 position.

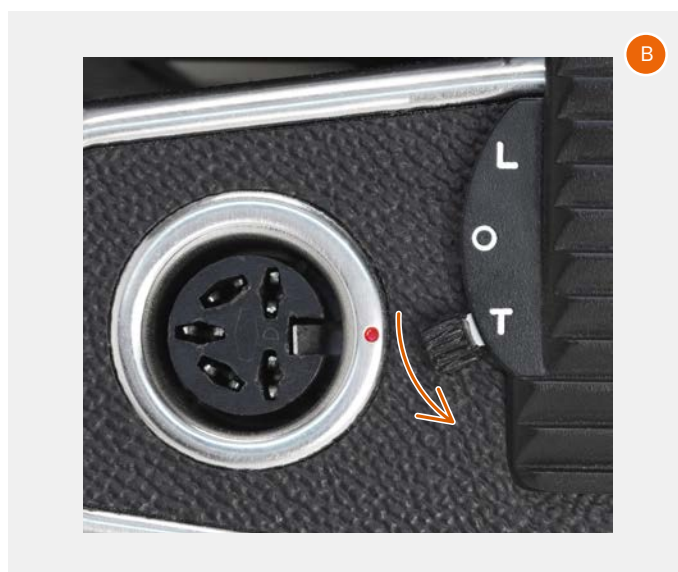
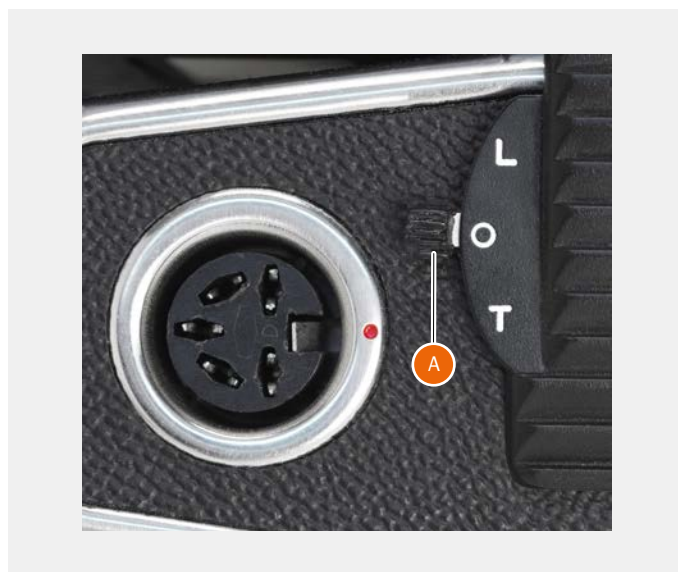

REMOTE CONTROL OF A EL-TYPE CAMERA

Note! For an **ELD** camera, no extra cable is needed.

Connect the exposure cable EL **(A)** between the CFV and the socket at the bottom right of the Winder EL camera. The 2.5mm connector shall be connected from the ELX socket on the CFV **(B)**.

When the camera is connected via USB to a computer running Phocus, you can release the camera from the computer. See separate Phocus user guide for more details.

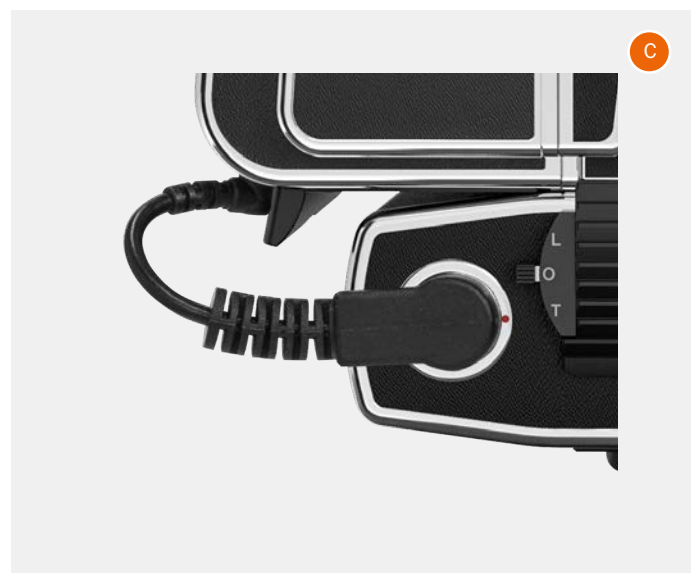

5.15 THE CFV ON A CAMERA USING FLASH-SYNC

The Any (Flash Sync) setting in the camera body menu (see page 73) is for cameras having a flash sync socket and that are not listed in the camera body setting menu. Examples of such cameras are technical cameras/View cameras **(A)** and ArcBody cameras **(B)**.

The basic operation is described in the quick start chapter on page 16.

- Set camera body type to Flash Sync as described on page 73.
- Connect the Flash Sync Input cable **(C)** from the sync socket of the lens **(D)** to the Flash Sync input on the CFV **(E)**.



START LIVE VIEW WITH A CAMERA USING ANY (FLASH SYNC)

- 1 Make sure the lens is open. Details on how to do this depends on the actual lens.
- 2 Activate live view from the Control Screen (LV).
- 3 Press the Menu button or Play/On-Off button to end Live View.

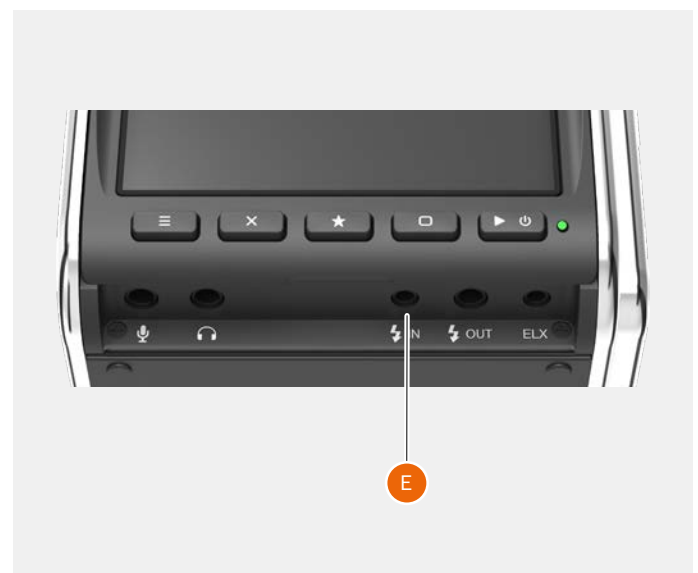
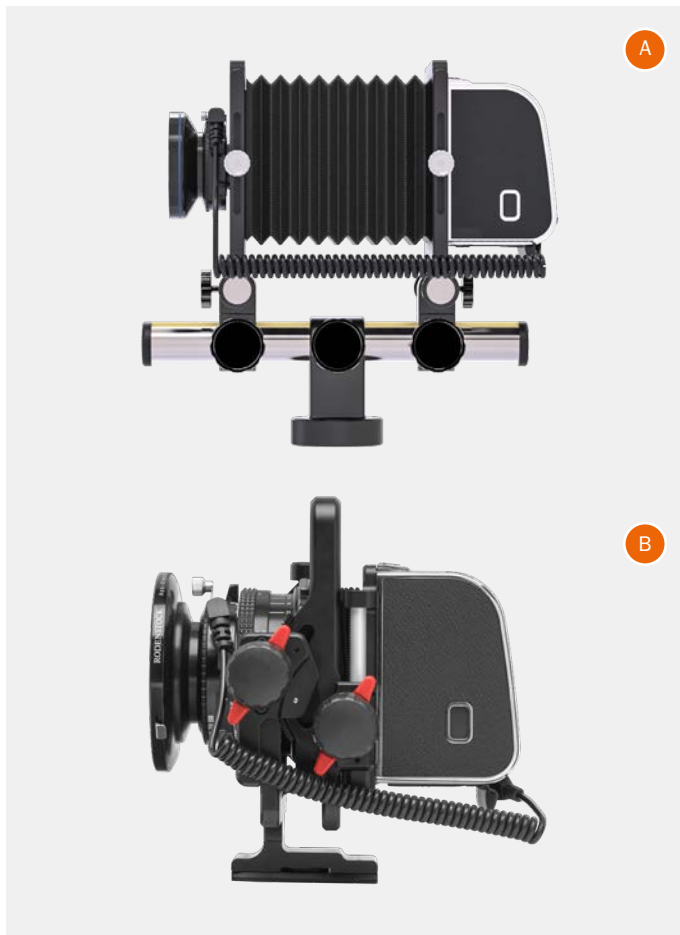

5.16 THE CFV ON A CAMERA USING THE ELECTRONIC SHUTTER

In the Any (Electronic Shutter) setting in the camera body menu (see page 73) the electronic shutter of the sensor is used. This is for use with lenses/cameras with no shutter.

The basic operation is described in the quick start chapter on page 16.

In this mode, the CFV uses the electronic shutter function and the control screen will look like **(A)**. There are additional controls for:

- Start capture **(1)**.
- Shutter speed **(2)**.

To change shutter speed, tap the value and the screen will show a list of available shutter speeds **(B)**. From this list, select a new shutter speed and tap on it to close and return to normal control screen **(A)**. Shutter speed can be set between 68 minutes and 1/10000 second.

Note!

Flash cannot be used in electronic shutter mode.

Note!

The rolling shutter effect limits the use to subjects with little or no movement.

START LIVE VIEW WITH ELECTRONIC SHUTTER

Tap the LV icon on the control screen. You can also press the Cross or Rectangle buttons until the live view icon is highlighted with orange color. Then press the Star button to start live view. Press Menu button or Play/On-Off button to end live view.

When live view is active **(C)**, the standard overlay shows:

- Release button **(4)**.
- Electronic Shutter indication **(5)**.
- Shutter speed **(6)**.
- Remaining captures **(7)**.
- Current ISO **(8)**.
- Battery status **(9)**.

To make an exposure, tap the shutter release Button **(4)**. This button can be moved to a different location by pressing and holding the button for one second. Then slide to move to the new location.

The shutter release button is available with all overlays, except the full screen overlay.

Note!

You can change overlay by pressing the Rectangle button **(3)**.

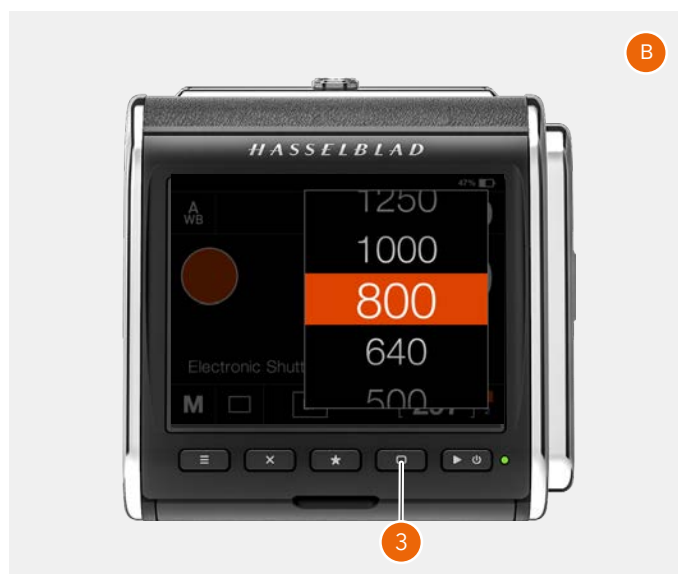
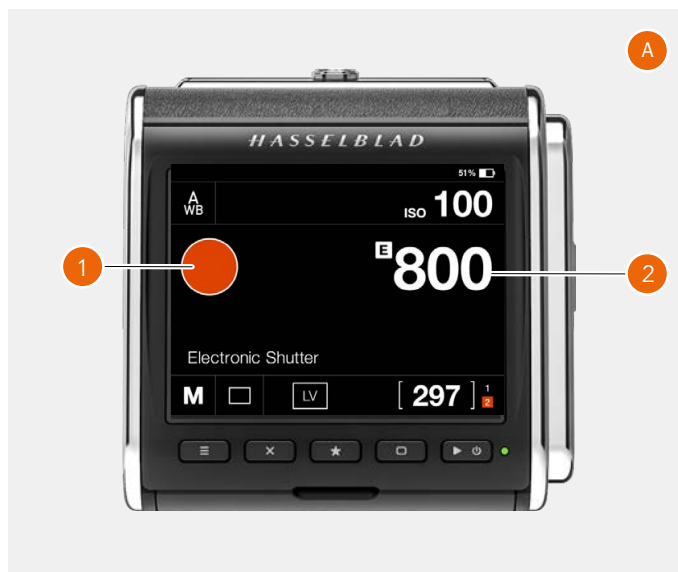

ADDITIONAL SETTINGS FOR ELECTRONIC SHUTTER

If camera body type is set to Any (Electronic Shutter), one additional setting is added to the camera settings Menu menu.

MAIN MENU > CAMERA SETTINGS > EXPOSURE

- 1 Press the camera icon on the touch display.
- 2 The camera settings menu appears.
- 3 Press Exposure.
- 4 The Exposure menu appears.

Swipe right or press the Menu button to get back to the main menu.

Exposure settings:

With this setting you can select the shutter speed increment step.

Select between:

- 1 (whole stops)
- 1/2
- 1/3

Continued on the next page.

Camera Body Menu

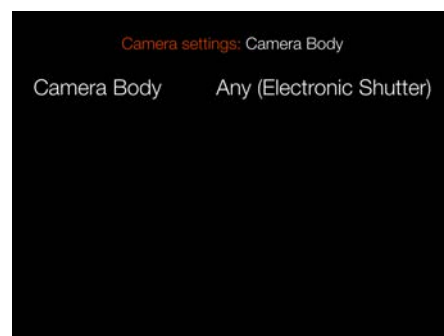

Exposure Menu



Whole stop setting



Available shutter speeds

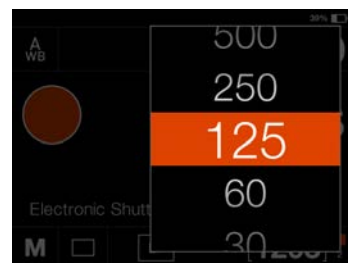

Half stop setting



Available shutter speeds

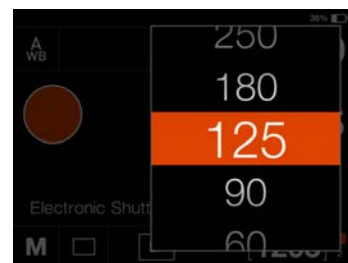

Third stop setting



Available shutter speeds

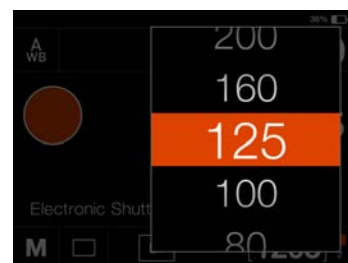

Drive mode settings on the control screen

By tapping the drive mode icon (**E**) on the control screen, you can select between the following drive modes:

- Single**
 The camera will only make one exposure regardless how long the shutter release button is pressed. Tap the Single icon again (**F**) to close the dialogue make it active.
- Continuous**
 The camera will make exposures as long as the Shutter release button is pressed. Tap the Continuous icon (**G**) again to close the dialogue make it active. Continuous drive mode requires the Release Cord X connected to the microphone input. See page 114.

B AND T MODE EXPOSURES

To use long exposures in B or T mode with Electronic shutter mode, the Release Cord X must be used.

B-mode

First set B as shutter speed on the Control Screen (**A**). Then press and hold the release button on the Release Cord X. A count-up timer (**B**) will show elapsed time. Release the button to stop the exposure.

T-mode

Set T as exposure time on the Control Screen (**C**). Press the release button on the Release Cord X and let go of the button. The T exposure will continue until you press the release button again or press the cross button **X**.

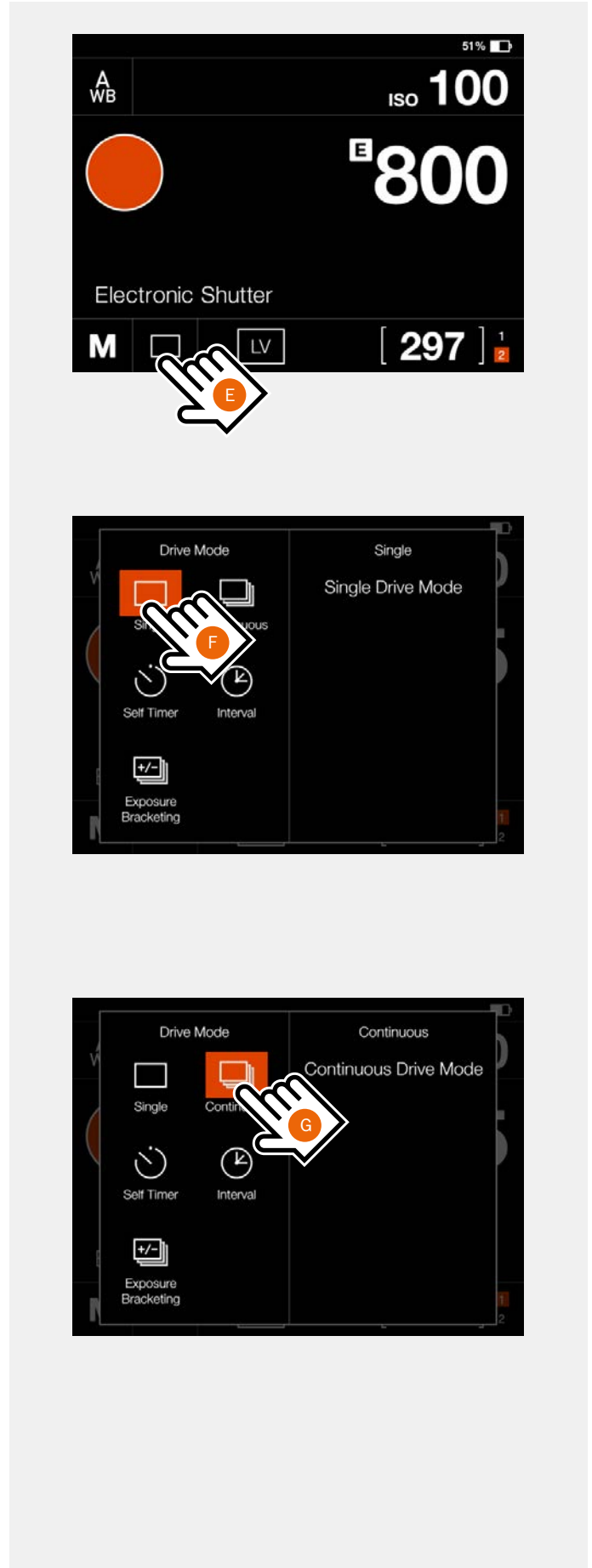
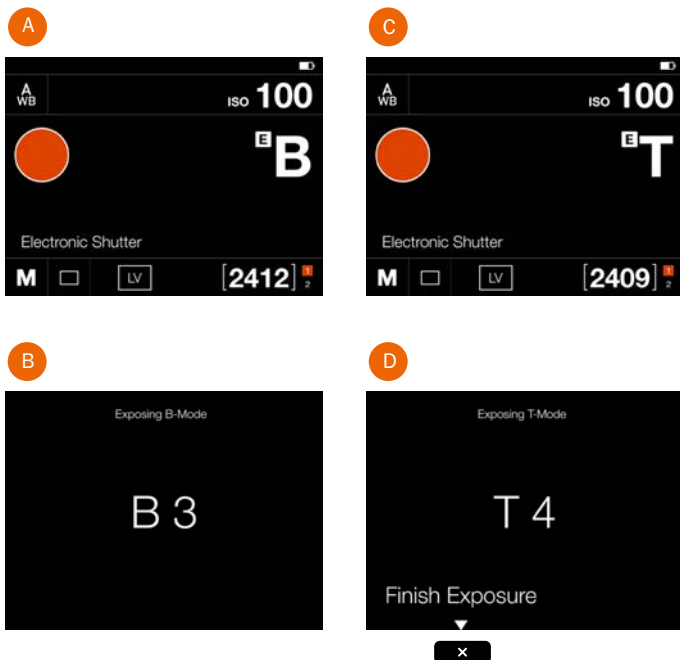

- **Self Timer (A)**

The camera will wait a pre-set time to make the exposure after the Shutter release button is pressed.

Time: Delay between shutter release and exposure.

When Finished: Determines if the function shall be active after a completed cycle or not. If set to **Exit**, the Self Timer is disabled after the exposure.

- **Interval (B)**

The camera will make a pre-determined number of exposures with a pre-set interval time.

Time: The time between exposures.

Frames: How many exposures will be made.

Initial Delay: Delay between shutter release and first exposure.

- **Exposure bracketing (C)**

The camera will automatically make a pre-determined number of exposures with a pre-set adjustment to the shutter speed between each frame.

Amount: How much exposure difference between each exposure.

Frames: The number of exposures in the sequence.

Initial Delay: A delay between shutter release and the first exposure.

Initial Delay: Delay between shutter release and first exposure.

Param in M: This function is only available when using the 907X camera body.

Sequence: Determines which order exposure adjustment is added.

When Finished: Determines if the function shall be active after a completed cycle or not.

Self Timer

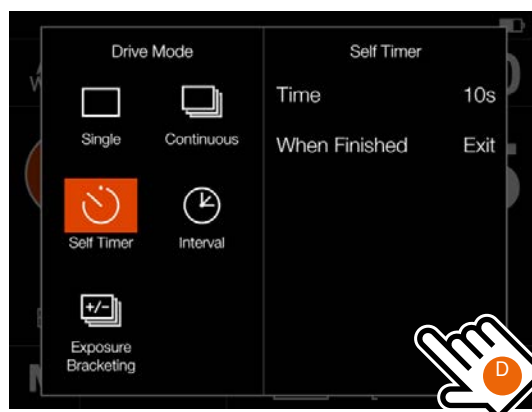

Interval

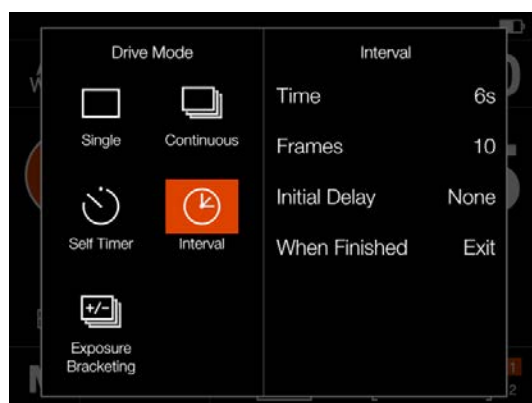

Exposure Bracketing

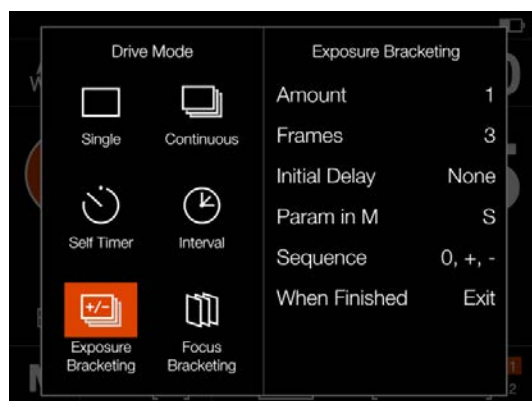

For **Self Timer**, **Interval** and **Exposure bracketing** the left part of the panel displays the current setting. If no changes are required, tap the function icon again to make it active. To change any of the parameters, tap the right part of the screen (**D**). This will bring up the dedicated settings for the function. See details on the following pages.

SELF TIMER SETTINGS

On the control screen tap the drive mode icon to bring up the settings screen **(A)**.

Tap the self timer icon **(1)**. To change settings, tap the right panel **(2)** to show the settings menu **(B)**.

To change any of the settings, tap the value **(3)** to bring up any of the screens **(E)** or **(F)**.

When the settings are made, tap the left arrow **(4)** to return to the drive mode settings screen. Finally, tap the self timer icon again to make it active.

When the shutter release is fully pressed, the rear screen will show the count down screen **(E)**. After the pre-set time is elapsed, the exposure will be made.

Select **Exit** by pressing the Cross button  if you want to cancel the self timer.

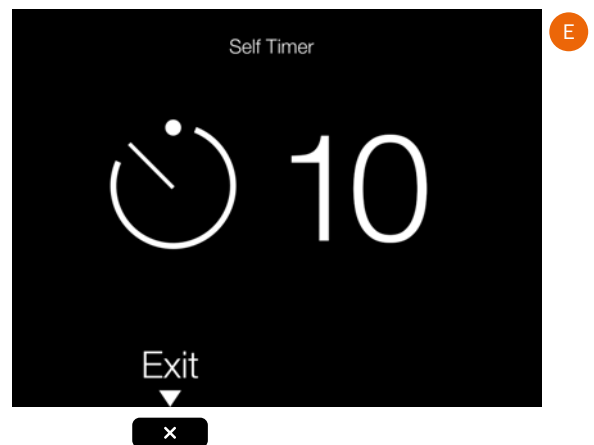
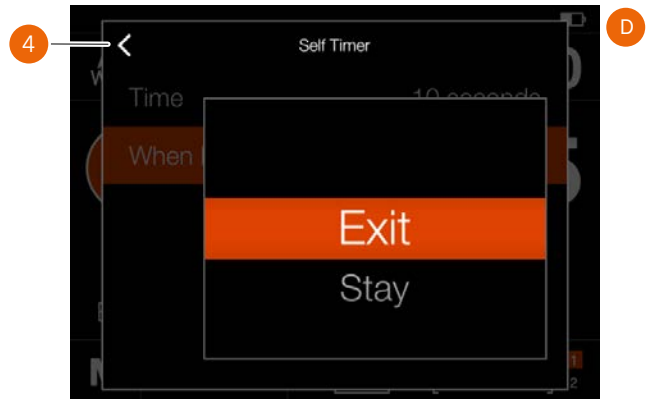
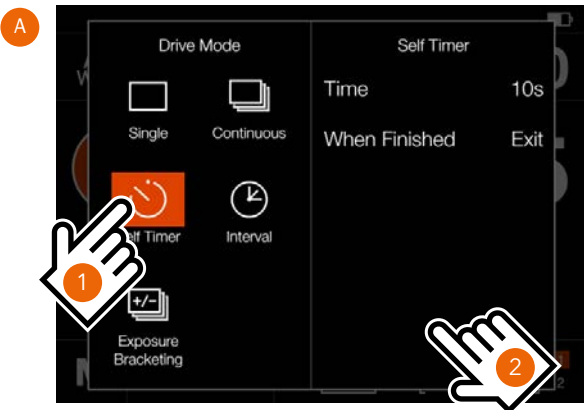

INTERVAL SETTINGS

On the control screen tap the drive mode icon to bring up the settings screen **(A)**.

Tap the Interval icon **(1)**. To change settings, tap the right panel **(2)** to show the settings menu **(B)**.

To change any of the settings, tap the value to bring up any of the screens **(C)** to **(F)**.

When the settings have been made, tap the left arrow **(4)** to return to the drive mode settings screen. Finally, tap the Interval icon again to make it active.

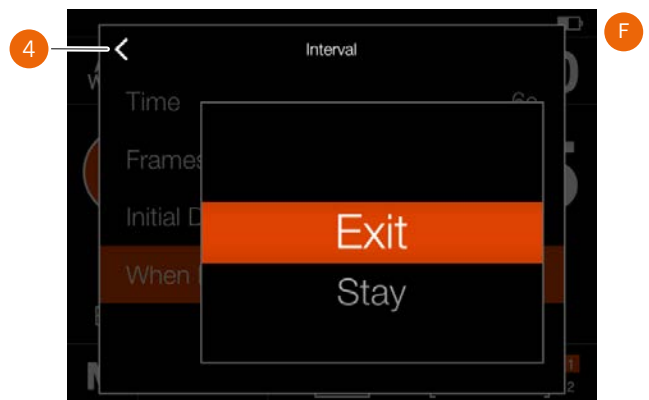
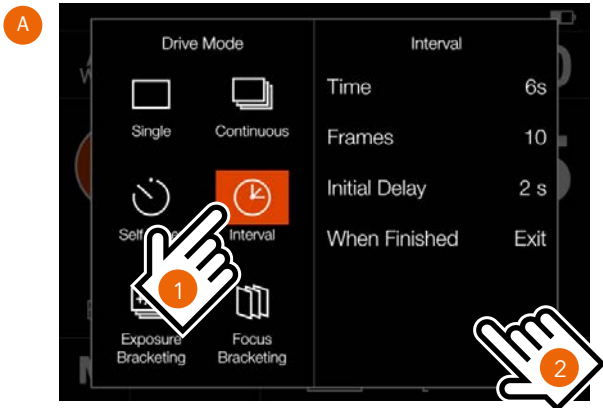

Continued on the next page.

INTERVAL OPERATION

An active and pending interval timer, is indicated both on the control screen and in live view.

the control screen shows the interval icon **(A)** and the interval time **(B)**. To see all settings, tap the Interval Icon to show the settings screen as described on the previous page.

Live view and preview screens show the same information **(C)** and **(D)** with the addition of remaining number of captures.

To start the sequence, press the shutter release. If you have set an initial delay to prevent camera shake, the camera will first wait the pre-set number of seconds showing a black screen with a count-down timer, and then start the Interval sequence.

After a capture, the image will show up on the rear screen, together with the Interval information.

To end the sequence before all captures have been made, select **Exit** by pressing the Star button .

Note!

Live view is turned off during an interval sequence.

Note!

The preview can be turned off in the **General Settings > Preview > Rear Screen** setting.

Note!

During a running interval sequence, you can press the menu button to activate the control screen to check current status.

Note!

Interval is not supported in Phocus Mobile 2 or when tethered to Phocus. For tethered operation, use the Capture Sequencer function in Phocus.

Control screen

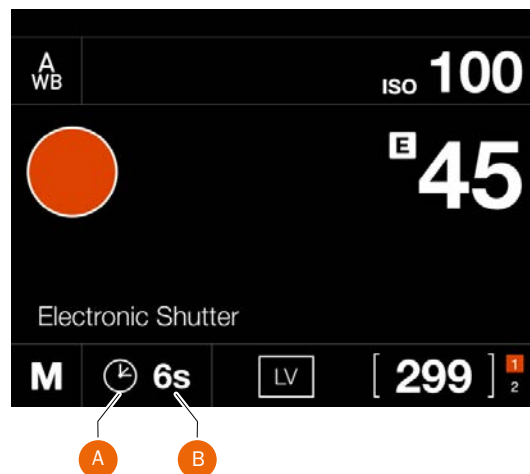

Live view

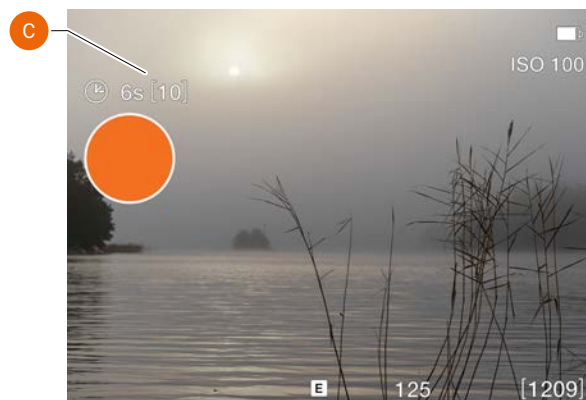

Preview screen after a capture



EXPOSURE BRACKETING SETTINGS

On the control screen tap the drive mode icon which brings up the settings screen **(A)**. Tap the exposure bracketing icon **(1)**. To change settings, tap the right panel **(2)** to show the settings menu **(B)**. To change any of the settings, tap the value to bring up any of the screens **(C)** to **(G)**.

When the settings have been made, tap the left arrow **(4)** to return to the drive mode settings screen. Finally, tap the exposure bracketing icon again to make it active.

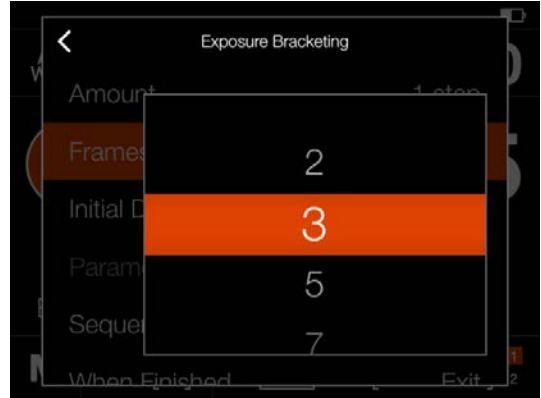

D

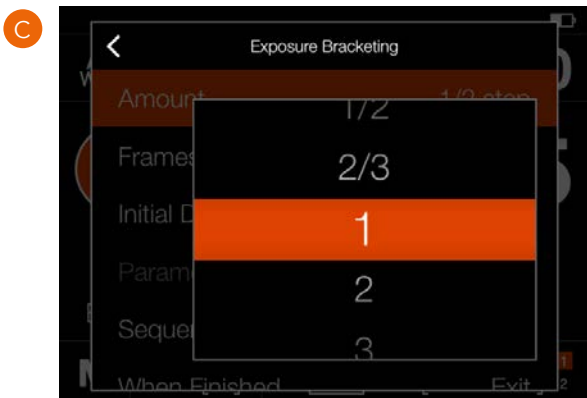
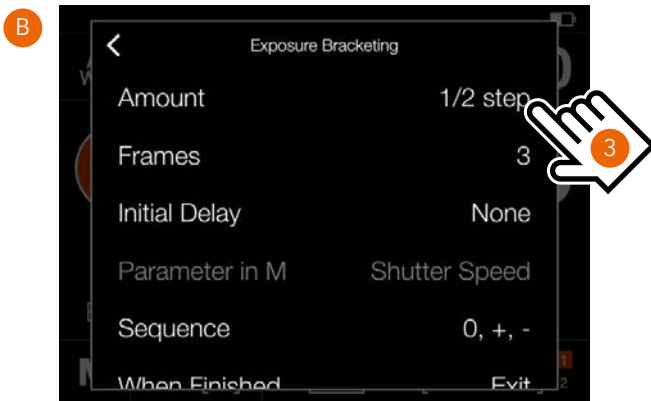
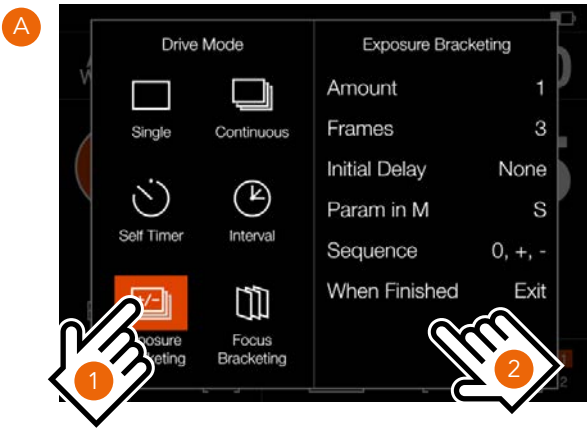

C

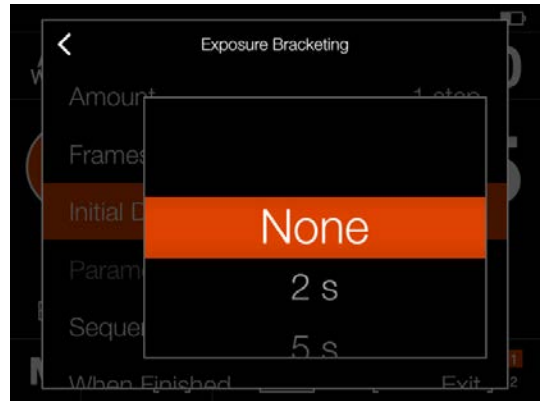

E

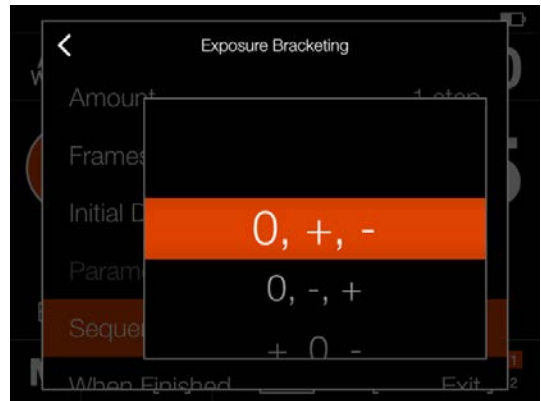

F



G

5.17 WORKING WITH FLASH

Flash can be used with most combinations of CFV and camera body except for the Any (Electronic Shutter) setting. The following section will cover important things to consider in order not to cause damage to the equipment.

Note!

For studio use where you have a desktop computer and a flash system connected to the mains outlet, it is important that both the computer and the flash are connected to mains outlets with a common ground.

Alternatively you can use remote flash trigger to electrically separate the flash from the camera and computer.

500 type cameras

The flash sync cable can be connected directly to the sync socket of the lens as shown in **(A)**.



Modified 200 cameras with a C type lens

When using a C type lens in C shutter mode, connect the flash sync cable to the sync socket of the lens as shown in **(B)**.



Modified 200 cameras with a F type lens

When using a F type lens or a C type lens in F shutter mode, connect the flash sync cable to the sync socket of the camera body as shown in **(C)**.



Note!

Flash cannot be used in combination with camera body type Any (Electronic Shutter).

Continued on the next page.

Cameras with Any (Flash Sync) setting

When using the Any (Flash Sync) setting, e.g. with a technical camera, you need to connect the Flash Sync input cable from the sync socket of the lens to the Flash In input on the CFV **(1)**. Then connect the Flash sync output cable from the Flash Out socket **(2)** to the flash as shown in **(A)**.

Cameras with Any (Electronic Shutter) setting

When this setting is used, the CFV will use the electronic shutter function which is not compatible with flash.

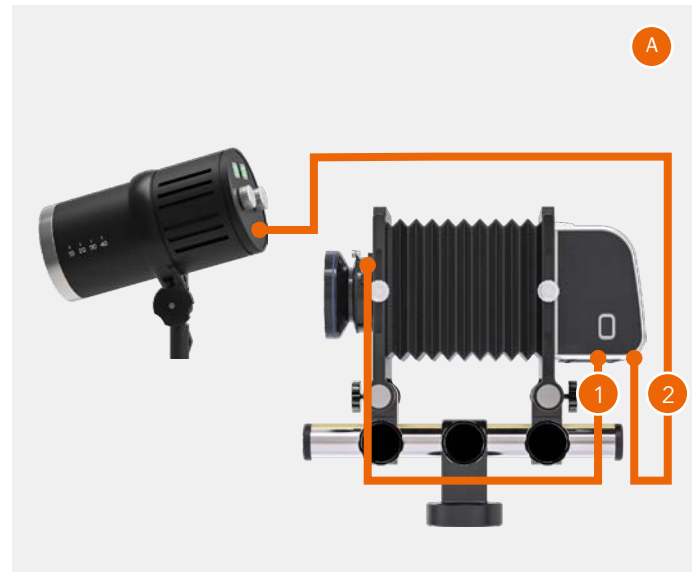

5.18 IMAGE RATING

RATING FUNCTION

Images on the memory card, can be rated from 1 to 5 Stars. The rating is written to the meta-data of the image file. Use the following procedure.

- 1 Make sure that the setting "Image Rating" in the **Camera Settings > Configuration** menu is checked. See page 81.
- 2 Press the Play button to enter Browse Mode.
- 3 Select the Capture Details overlay by pressing the Display Button or by rotating the rear Scroll Wheel **(A)**.
- 4 In the lower right part, the 5 stars **(B)** show the current rating. For an unrated image, no stars are filled.
- 5 To rate the image, tap the five stars **(B)** or press the Star Button.
- 6 The camera enters Rating Mode, showing five large stars. If the image has been rated before, it will show the current rating, otherwise, the five stars will be empty.
- 7 Tap the desired star to change rating. E.g. if you want a 4-star rating, tap the fourth star **(C)**. The Rectangle Button increases rating and the Cross Button decreases rating. You can also use the rear Scroll Wheel to change rating.
- 8 To return to Browse Mode **(D)**, press the Star Button or the Browse Button again.

Rating Mode is equivalent to standard Browse Mode, which means that you can browse to the next image by swiping the display or using the front Scroll Wheel. Double-tap the screen to Zoom-in.

You can always go back to a previously rated image and change rating following the same procedure as above.

Note!

For an efficient work-flow while rating many images, stay in Rating mode and swipe to the next or previous image. It is also possible to use the front scroll wheel to go to the next or previous image while in Rating mode.

Note!

If Image rating is deactivated in the setting **Camera Settings > Configuration > Image Rating**, the five stars in Browse Mode **(A)** will not be visible.

Note!

Only images on the primary card can be rated.

Note!

When camera body type is set to Any (Electronic shutter), the screen includes more information **(E)**.

Browse mode - Capture Details Overlay

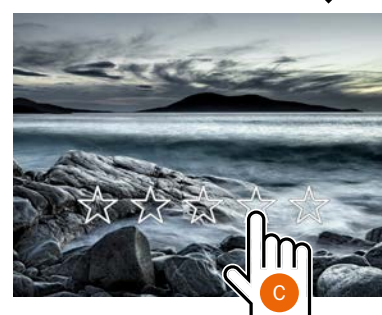

5.19 VIDEO RECORDING

The CFV II can be used to record video on any camera that can be set to open mode as previously described for Live View:

- 500 Cameras on page 51.
- 200/2000 Cameras on page 53.
- SWC Cameras on page 54.
- EL Cameras on page 55.
- Flash Sync Cameras on page 58.
- Cameras using the Electronic Shutter on page 59.

Video can be recorded in 2.7K (2720 x 1530) and HD (1920 x 1080) in 29.97 fps. Settings for video are explained on page 82.

To record audio, connect a microphone to the microphone input. See page 47. We recommend an active microphone for best audio quality.

- 1 Show the Control Screen by clicking the Menu button.
- 2 Tap the Exposure Mode icon (B) to bring up the exposure mode setting screen (C).
- 3 Tap the Video icon (D).
- 4 To start Live View, tap the Live View icon (E).
- 5 When Live View is active you can compose and focus. For precise focusing, press the star button or double-tap the screen to zoom in. Press the star button or double-tap again to zoom out.
- 6 If the screen is too dark, use the cross button to set a longer exposure time (F). Pressing the rectangle button will shorten the exposure time. You can also tap the ISO value on both the Control Screen and Live View screen and set a new ISO value if required.
- 7 To start recording, tap the red recording button (G).
- 8 An ongoing recording is indicated by a blinking "REC" in the upper part of the screen.
- 9 To stop recording, tap the stop icon (H).

Note!

Video recording is not possible in tethered mode.

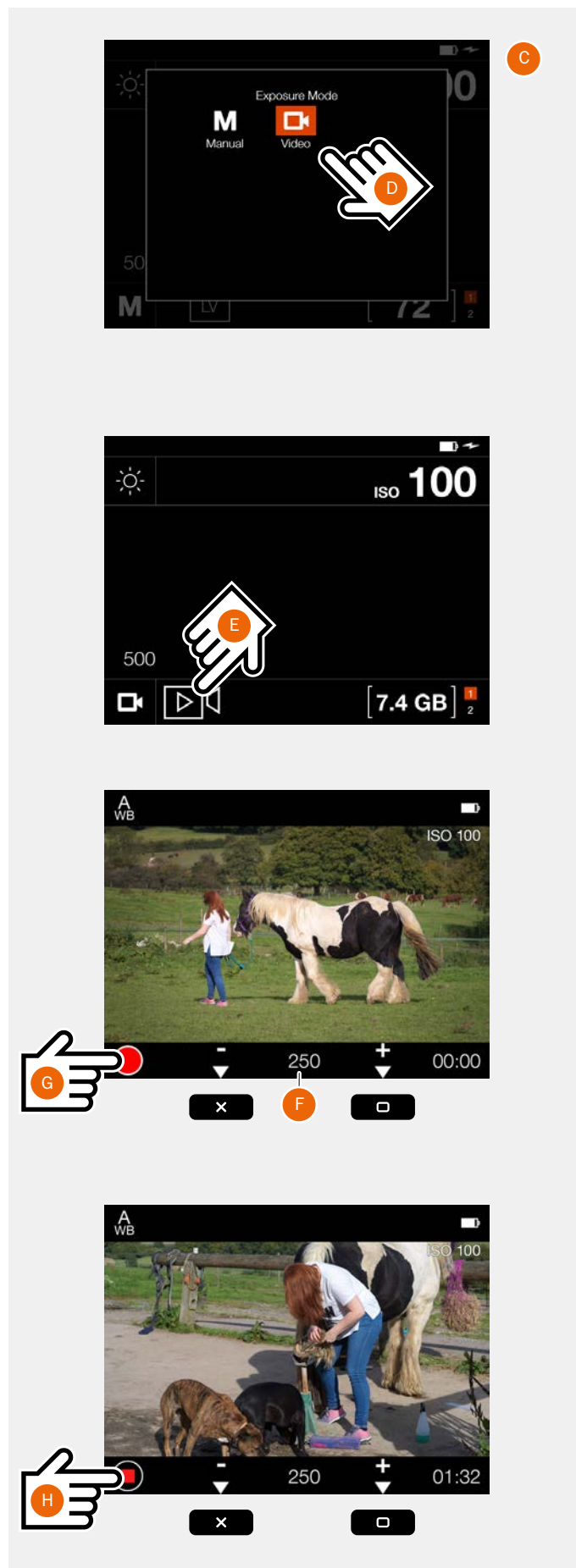

5.20 VIDEO PLAYBACK

To browse recorded videos, press the play button **(A)** and scroll until a video is shown. Video files are indicated by a large white arrow.

To start playback, tap the white arrow **(B)**. You can pause playback by tapping the screen **(C)**.

You can fast forward or reverse by sliding the small white marker **(D)** in the progress bar to the right or left.

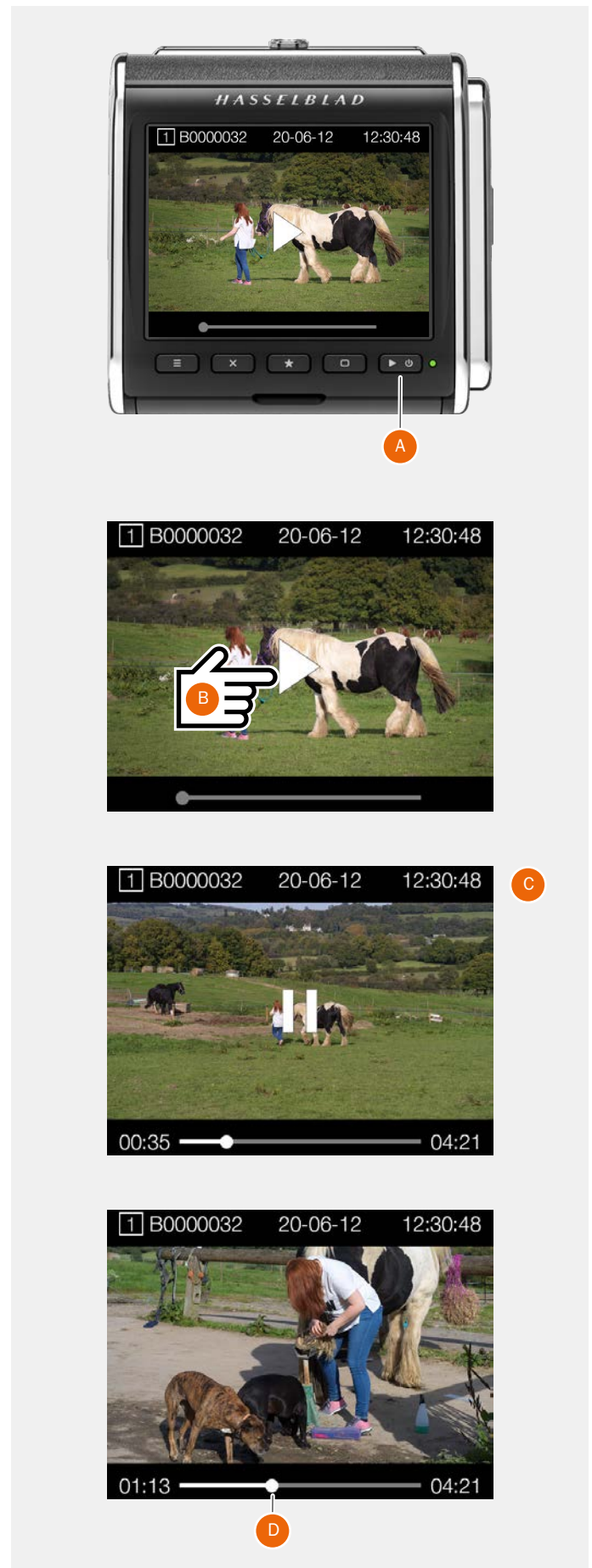

6.1 THE CAMERA SETTINGS MENU

CAMERA BODY

Main menu

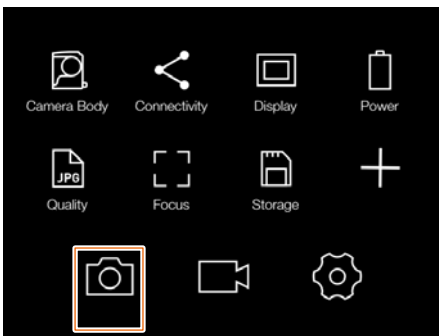

Camera settings menu

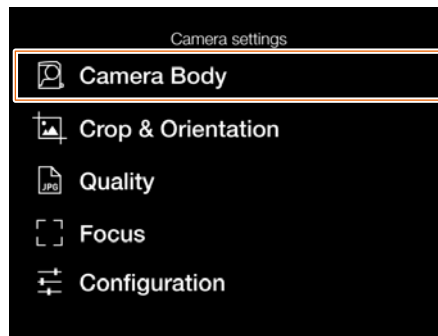

Camera body menu

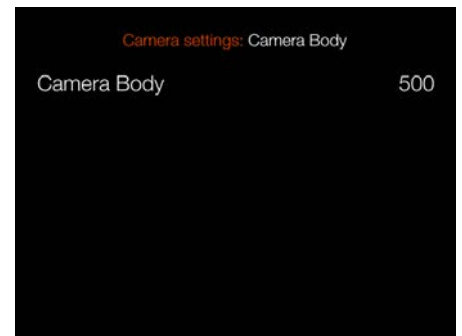

MAIN MENU > CAMERA SETTINGS > CAMERA BODY

- 1 Press the camera icon on the touch display.
- 2 The camera settings menu appears.

Swipe right or press the menu button to get back to the main menu.

Camera body settings:

Select which camera the CFV will be used on.

Select between:

- 500
- 503 + Winder CW
- 200 Modified
- 200
- 2000
- SWC
- ELX
- ELD
- Any (Flash Sync)
- Any (Electronic Shutter)

A detailed description on how to use the CFV with all camera models can be found in the "Using the CFV" section starting on page 51.

Note!

If camera body type is set to Any (Electronic Shutter), one additional setting (Exposure) is available in the camera settings menu. Also see page 60.

Camera body menu with Any (Electronic Shutter), See page 60.

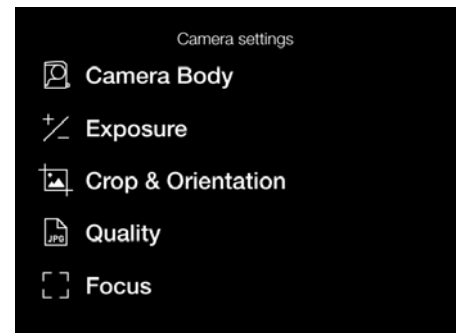

Camera body setting

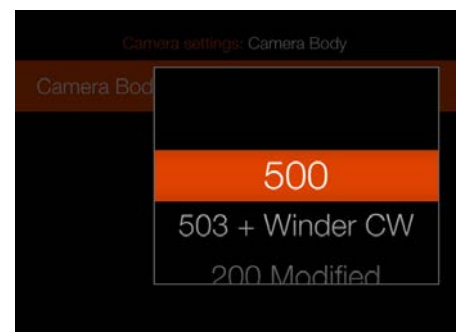

CROP & ORIENTATION

Main menu

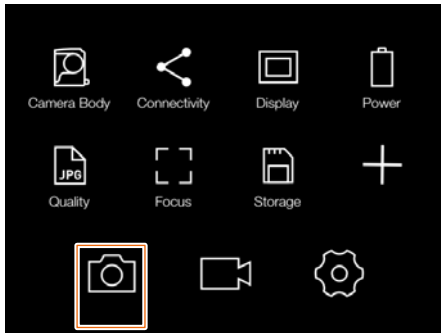

Camera settings menu

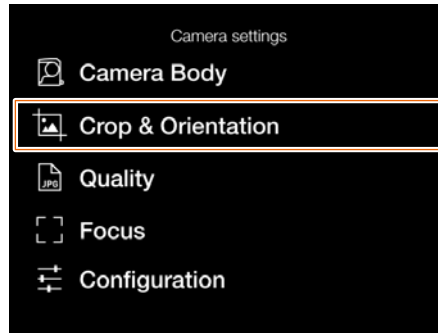

Crop & orientation settings menu

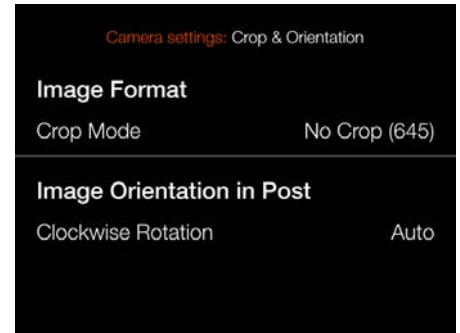

MAIN MENU > CAMERA SETTINGS > CROP & ORIENTATION

- 1 Press the camera icon on the touch display.
- 2 The camera settings menu appears.

Swipe right or press the Menu button to get back to the main menu.

Crop & Orientation settings are explained on the next page.

CROP & ORIENTATION SETTINGS

MAIN MENU > CAMERA SETTINGS > CROP & ORIENTATION

- 1 Press the camera icon on the touch display.
- 2 The camera settings menu appears.
- 3 Press the Crop & orientation settings menu.

Swipe right or press the Menu button to get back to the main menu.

Crop Mask settings:

Crop Mode

Adds a crop mask to live view and the RAW file. When imported to Phocus, the crop mask can be modified or removed.

Crop Mode settings:

- No Crop (645)
- 1:1 (6x6)
- 7:6 (6x7)
- 5:4 (4x5)
- 11:8,5 (Letter)
- 297:210 (A4)
- 3:2 (6x9)
- 3:2 Crop (24x36). See Notes below.
- 16:9 (Screen)
- 2:1 (6x12)
- 65:24 (XPan)

Notes!

- JPG files are not cropped.
- Crop modes are disabled in USB tethered mode.
- Crop modes are not supported in Phocus Mobile 2.

Continued on the next page.

Crop & orientation settings menu

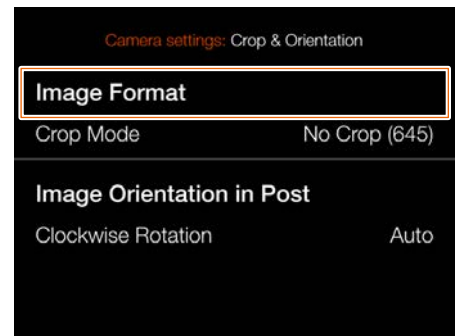

Crop setting

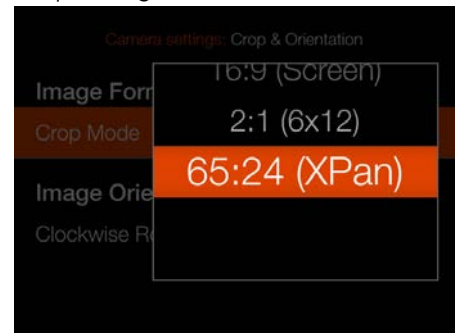

XPan crop



CROP & ORIENTATION SETTINGS

Image Orientation in Post settings:

Clockwise Rotation

Sets the viewing orientation of captures when they appear in Phocus. To avoid unintentional orientation changes when the camera is pointing straight up or down, the orientation setting can be locked.

Select between:

- Auto.
- Lock at 0 degrees.
- Lock at 90 degrees.
- Lock at 180 degrees.
- Lock at 270 degrees

Image format settings menu

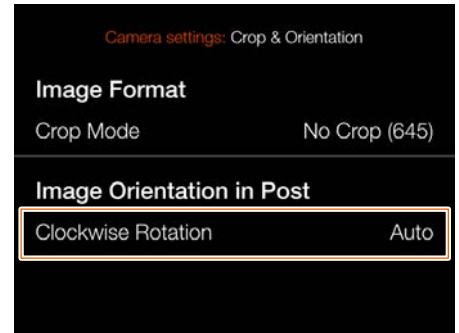

Orientation settings

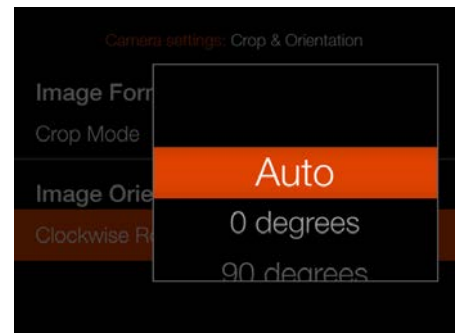

QUALITY

Main menu

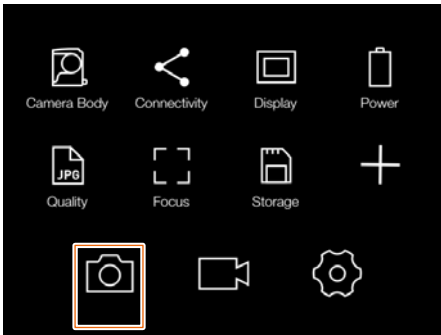

Camera settings menu

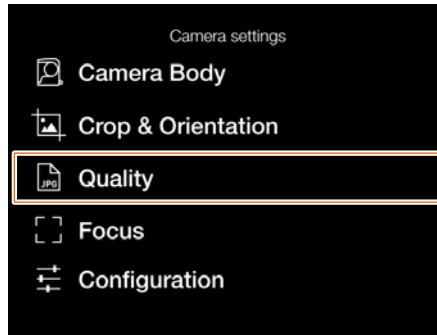

Quality settings menu

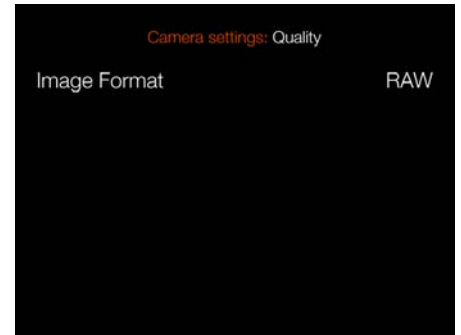

MAIN MENU > CAMERA SETTINGS > QUALITY

- 1 Press the camera icon on the touch display.
- 2 The camera settings menu appears.

Swipe right or press the Menu button to get back to the main menu.

Quality settings:

Selects format and quality for images stored on the card. RAW will provide best possible quality and JPG the highest number of images.

Image Format:

Select between:

- RAW
- RAW+JPG
- JPG

Note!

JPG files will be saved in full resolution and are fully color profiled.

Quality setting

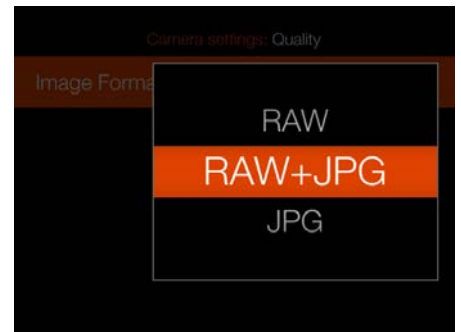

FOCUS

Main menu

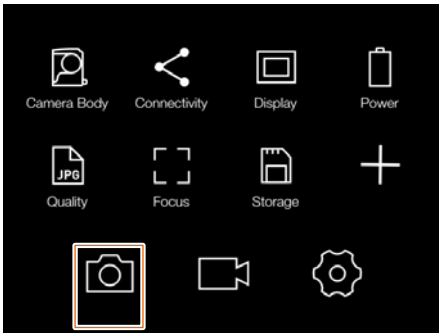

Camera settings menu

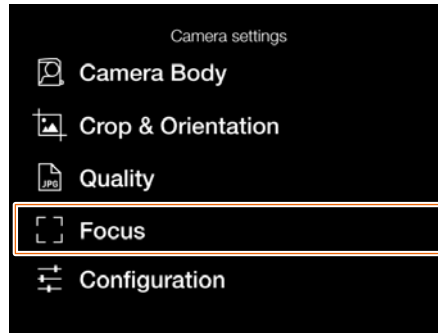

Focus settings menu

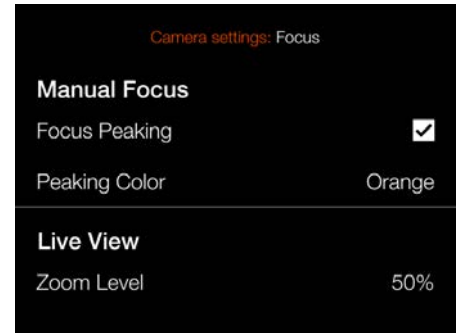

MAIN MENU > CAMERA SETTINGS > FOCUS

- 1 Press the camera icon on the touch display.
- 2 The camera settings menu appears.

Swipe right or press the Menu button to get back to the main menu.

Focus settings are explained on the next page.

FOCUS SETTINGS

MAIN MENU > CAMERA SETTINGS > FOCUS

- 1 Press the camera icon on the touch display.
- 2 The camera settings menu appears.
- 3 Press the focus settings menu.

Swipe right or press the Menu button to get back to the main menu.

Manual Focus settings:

The focus peaking function is a manual focus tool to help you identify what areas of the subject that are in focus. Focus peaking is not active in auto focus mode.

When the focus peaking is active and focus is adjusted manually, the focused area of the subject (magenta in this case) moves in depth as you move the focus.

Focus Peaking:

Select between:

- On
- Off

Peaking Color:

Select between:

- Orange
- Yellow
- Cyan
- Magenta

Focus settings menu

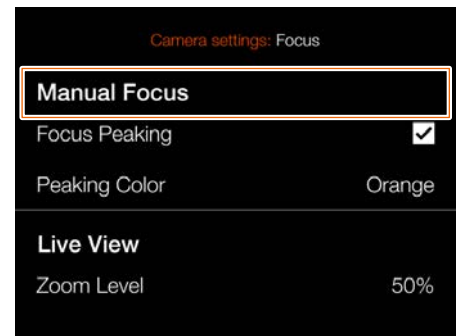

Peaking color setting

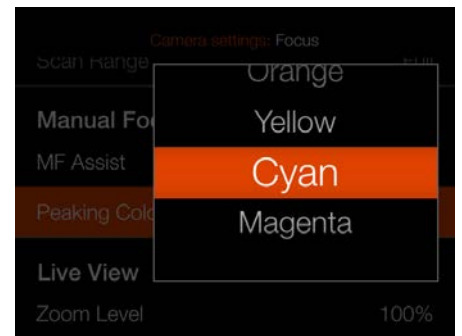

Subject not in focus when focus peaking is active

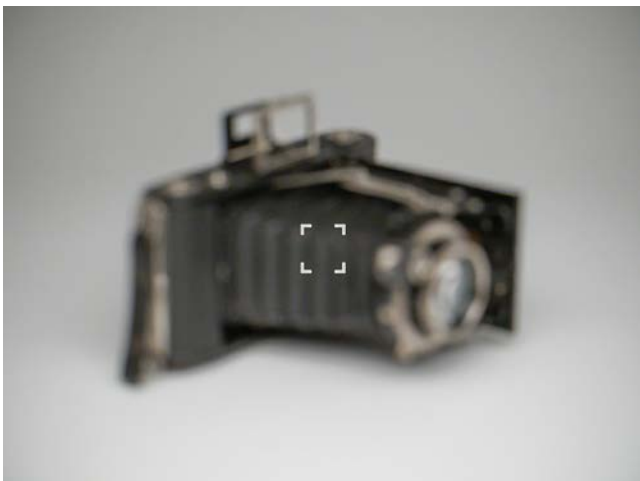

Focus peaking display when subject parts are in focus



FOCUS SETTINGS

MAIN MENU > CAMERA SETTINGS > FOCUS

- 1 Press the camera icon on the touch display.
- 2 The camera settings menu appears.
- 3 Press the focus settings menu.

Swipe right or press the Menu button to get back to the main menu.

Live View settings:

The zoom level setting controls the zoom-in level in live view and browse modes.

Zoom Level:

Select between:

- 50%
- 100%

When zoomed-in, a grey rectangle **(1)** is shown in the lower right corner. The small white rectangle **(2)** indicates the position in the image and will move as you pan in the image.

Focus settings menu

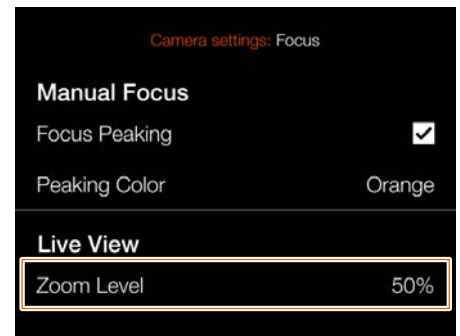

Live view, full image



Live view, 50% zoom



Live View, 100% zoom



CONFIGURATION

Main menu

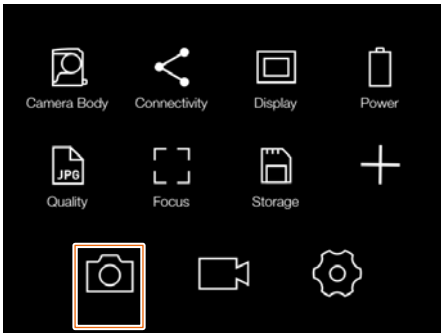

Camera settings menu

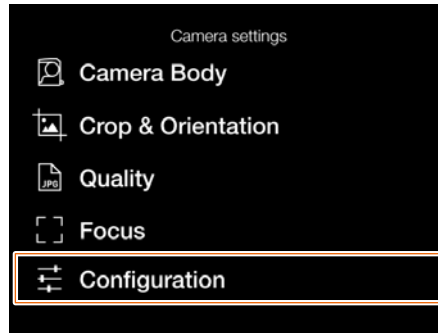

Configuration settings menu



MAIN MENU > CAMERA SETTINGS > CONFIGURATION

- 1 Press the camera icon on the touch display.
- 2 The camera settings menu appears.

Swipe right or press the Menu button to get back to the main menu.

Image rating

Image Rating

If the box is checked, the star button is used for image rating in browse mode. See page 69.

6.2 THE VIDEO SETTINGS MENU

Main menu

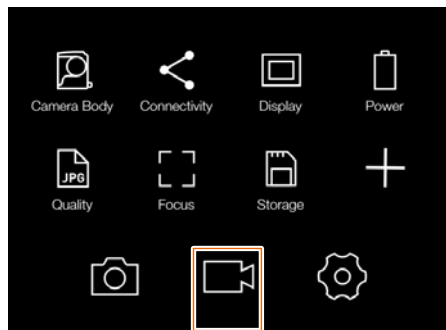

Video Settings Menu



Video Quality Settings

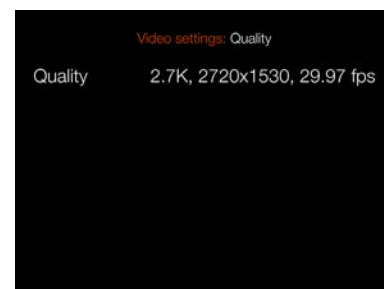

MAIN MENU > VIDEO SETTINGS

- 1 Press the Video icon on the Touch Display.
- 2 The Video Settings Menu appears.
- 3 Select a Video Setting.

Swipe right or press the Menu / EXIT button to get back to the Main Menu.

QUALITY

Resolution

Video Quality Resolution Setting

Select from:

- 2.7K (2720 x 1530 pixels)
- Full HD (1920 x 1080 pixels)

Frame rate is 29.97 fps.

AUDIO

External. Selects recording level for the external microphone.

Select between:

+12 dB, +6 dB, Normal, -6 dB, -12 dB, -18 dB or Mute.

Resolution Setting

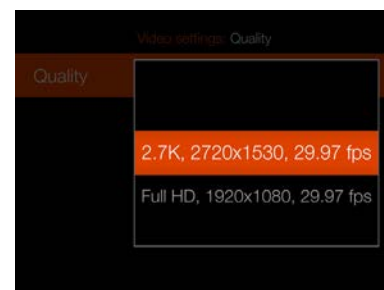

Audio Settings

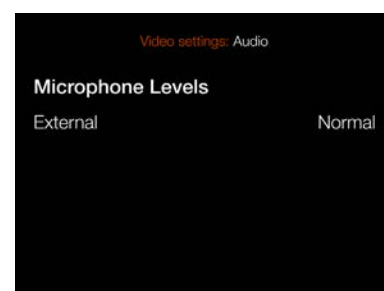

Audio level settings

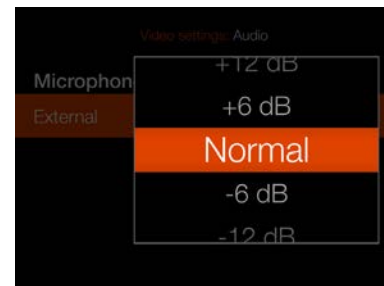

LIVE VIEW

Overlay

Selects the overlay for video Live View screen.

Select from:

- None.
- Grid. Displays a 1/3 grid on the Video Live View screen.
- Focus Peaking.
- Grid + Focus Peaking.

Note!

You can toggle the overlay On or Off by pressing the Display button while in Video Live View.

Note!

Video recording is not possible in tethered mode.

Video Settings Menu

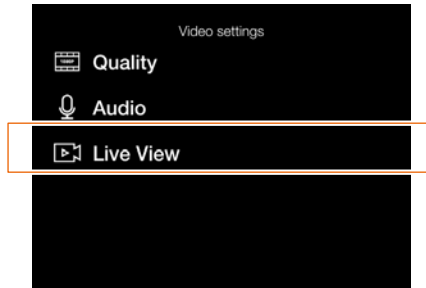

Live View Settings

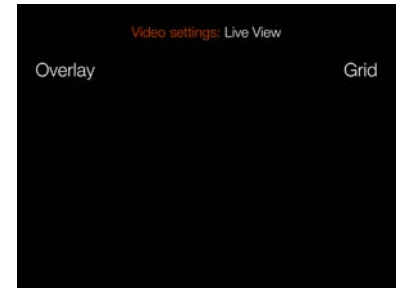

Overlay Setting

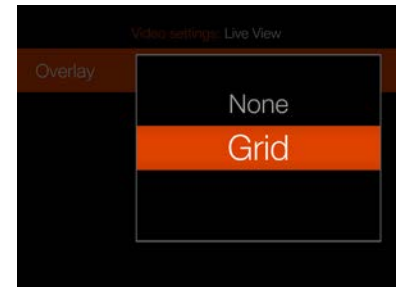

Video Live View screen with grid enabled



6.3 THE GENERAL SETTINGS MENU

CONNECTIVITY

Main menu

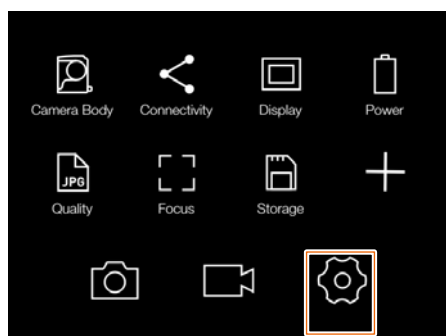

MAIN MENU > GENERAL SETTINGS > CONNECTIVITY

- 1 Press the general settings icon on the touch display.
- 2 The general settings menu appears.

Swipe right or press the Menu button to get back to the main menu.

Connectivity settings are explained on the next page.

General settings menu

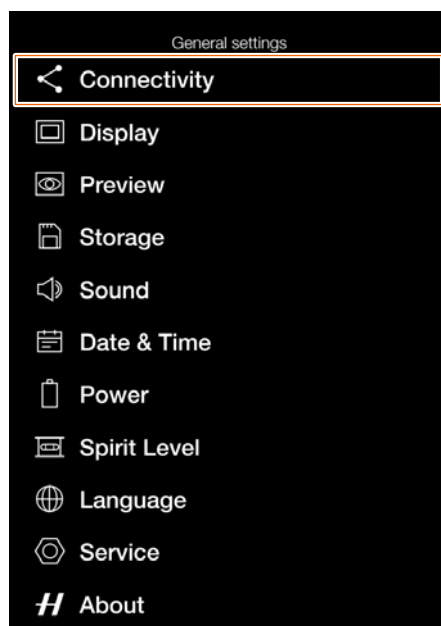

Connectivity settings menu



CONNECTIVITY SETTINGS

MAIN MENU > GENERAL SETTINGS > CONNECTIVITY

- 1
- 1 Press the general settings icon on the touch display.
- 2 The general settings menu appears.
- 3 Press the connectivity settings menu.

Swipe right or press the menu button to get back to the main menu.

USB settings

Tethering Mode

Select between:

- Mac/PC
- iOS

If the camera is connected via USB to an iOS device, select **iOS**. For connection to a computer select **Mac/PC**.

Wireless settings

Wi-Fi

Select between:

- On
- Off

Mode

Select between:

- 2.4 GHz
- 5 GHz

SSID

The identity of the camera on the wireless network. See page 109 and page 110 for more info on connection options.

Password

Use this password to connect via Wi-Fi to the camera.

Change Password

Press this button to generate a new password.

Remove Paired Devices

Removes all devices that have been paired over Bluetooth for auto-connection with the Phocus Mobile 2 App. The number within brackets represents the current number of paired devices. If the button is greyed out, no devices have been paired. Press Remove (Rectangle button, □) to confirm or Exit (Cross button, ✕) to return without removing any device.

Note!

The display time-out will temporary be increased to 60 seconds when enabling Wi-Fi. If user touches the screen or press any key during this 60 second period the display time-out will be restored to normal value.

Note!

Some regions do not allow Wi-Fi or 5 GHz Wi-Fi.

Connectivity settings menu



Tethering mode setting

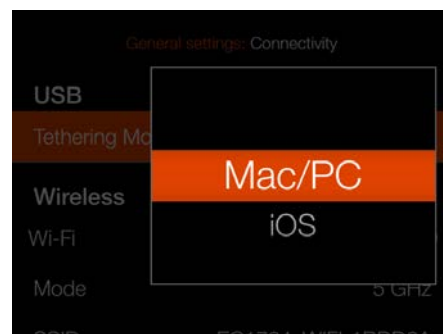

Change password dialogue

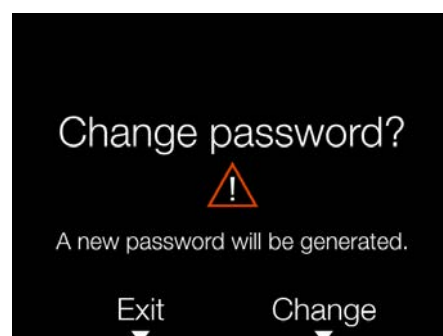

Remove paired devices dialogue

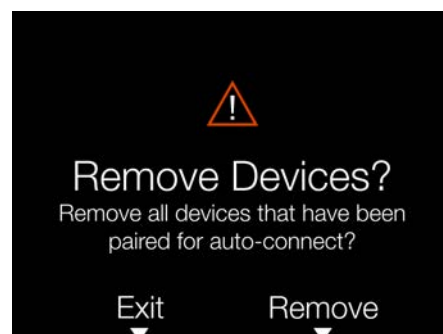

DISPLAY

Main menu

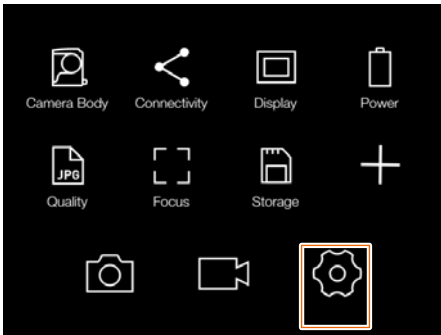

MAIN MENU > GENERAL SETTINGS > DISPLAY

- 1 Press the general settings icon on the touch display.
- 2 The general settings menu appears.

Swipe right or press the Menu button to get back to the Main Menu.

General settings menu

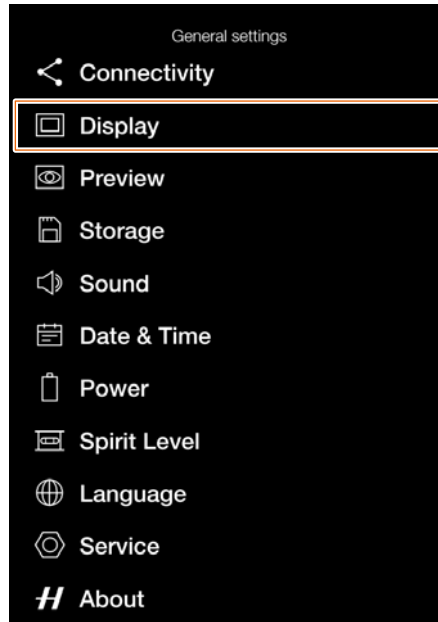

Display settings menu

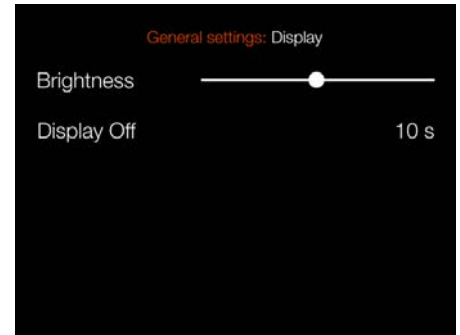

Display settings:

The first two settings control the brightness and contrast of the display. The Display Off setting controls how long time the display is active after an activation.

Brightness:

Use slider to set display brightness

Display Off:

Select between:

5sec, 10sec, 20sec, 30sec, 1min, 2min, 3min , 5min

Note!

You can force the CFV into standby mode to save power by pressing and holding the Menu button and making a short-press on the On/Off button.

Display off setting

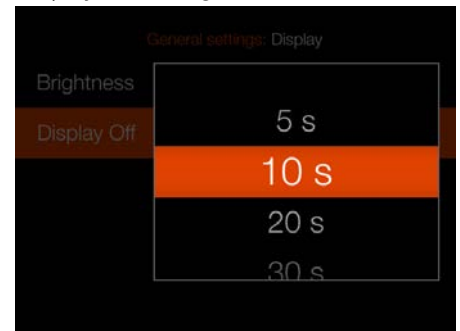

PREVIEW

Main menu

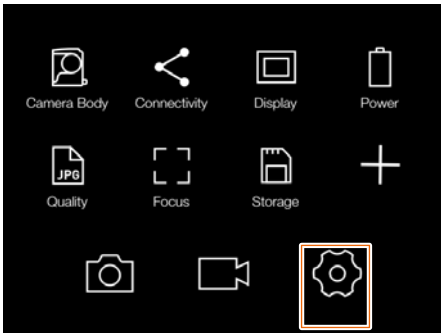

MAIN MENU > GENERAL SETTINGS > PREVIEW

- 1 Press the general settings icon on the touch display.
- 2 The general settings menu appears.

Swipe right or press the Menu button to get back to the main menu.

General settings menu

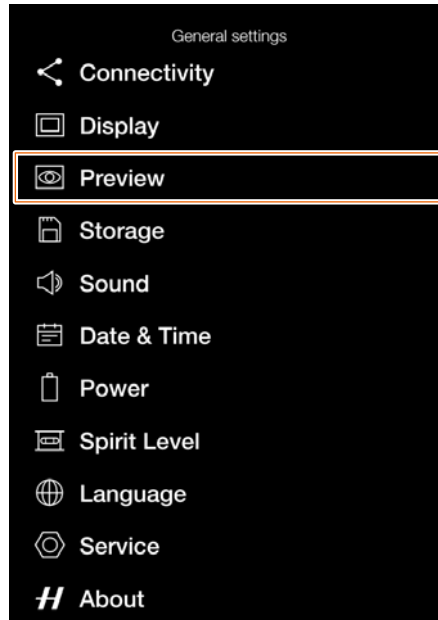

Preview settings menu

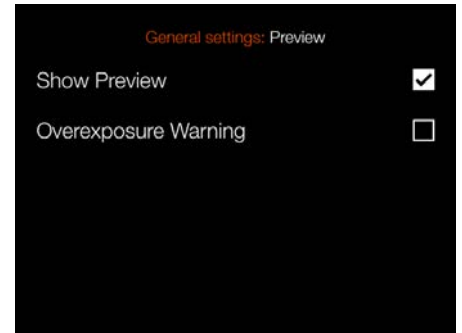

Preview settings:

Rear Screen:

Select between:

- On
- Off

When set to On, a preview will be shown on the display after each capture.

Overexposure Warning:

Select between:

- On
- Off

When set to On, areas close to being overexposed are alternating between white and black color.

STORAGE

Main menu

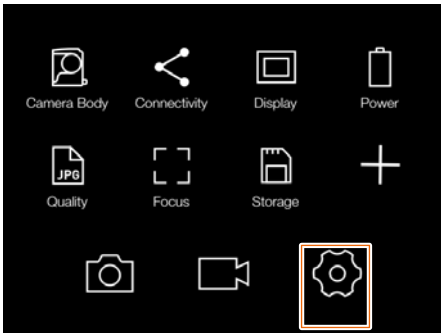

MAIN MENU > GENERAL SETTINGS > STORAGE

- 1 Press the general settings icon on the touch display.
- 2 The general settings menu appears.

Swipe right or press the Menu button to get back to the Main Menu.

Storage settings are explained on the next page.

General settings menu

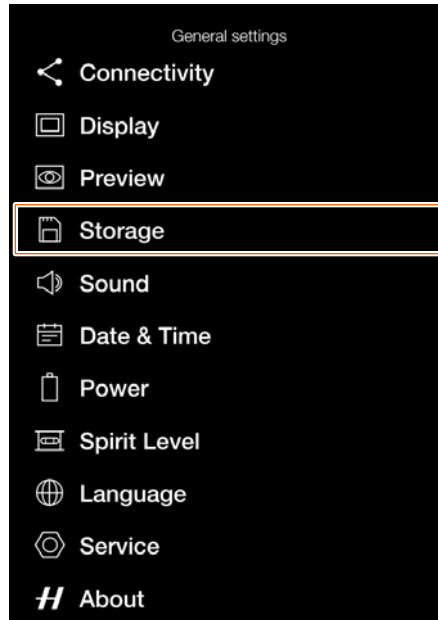

Storage settings menu

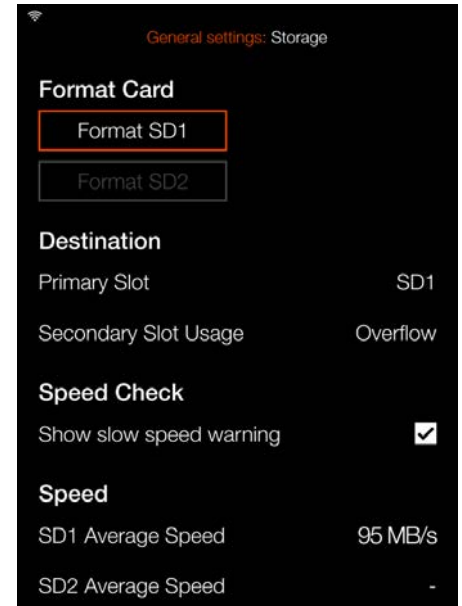

RECOMMENDED MEMORY CARDS

For optimal performance, the following SD memory cards are recommended to use:

- Sandisk Extreme PRO UHS-II 300MB/s
- Panasonic V90 UHS-II 280MB/s
- Toshiba EXCERIA PRO UHS-II 270MB/s

Note!

Avoid using Micro SD/TF memory cards with SD card sets. Some Sony high-speed G UHS-II SD 300MB/s memory cards might have poor compatibility, and therefore, might not be able to write image data properly. To avoid this, it is recommended to use only the recommended SD memory cards, as listed above, to ensure the image data security.

STORAGE SETTINGS

MAIN MENU > GENERAL SETTINGS > STORAGE

- 1 Press the general settings icon on the touch display.
- 2 The general settings menu appears.
- 3 Press the storage settings menu.

Swipe right or press the Menu button to get back to the main menu.

Storage settings:

Format SD1:

Pressing this button calls up the format dialogue for SD card #1.

Format SD2:

Pressing this button calls up the format dialogue for SD card #2.

Destination settings:

Primary Slot:

Select between:

- SD1
- SD2

Secondary Slot Usage:

Select between:

- Overflow
- Backup (Images)

Speed Check:

Select between:

- On
- Off

Speed

After 10 exposures a transfer speed value will be shown for the active card.

Note!

Video files will not be backed up.

Slow card dialogue

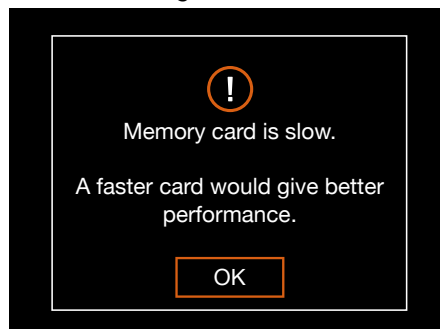

Storage settings menu

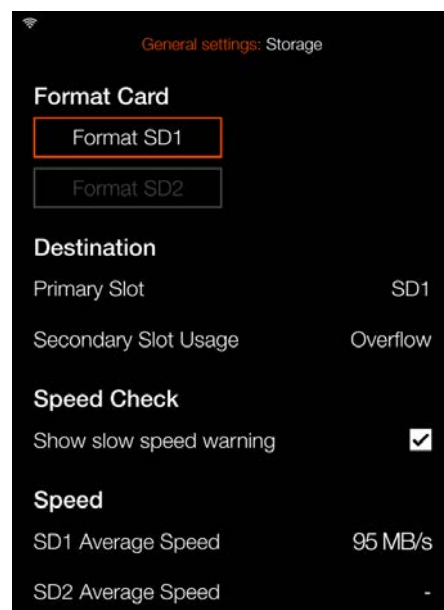

Format card dialogue

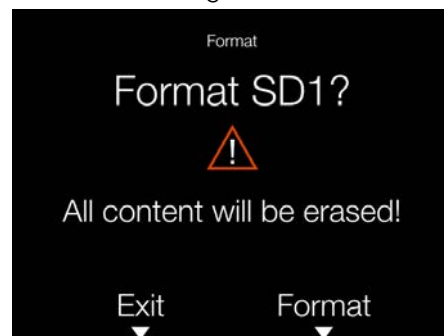

Storage destination setting

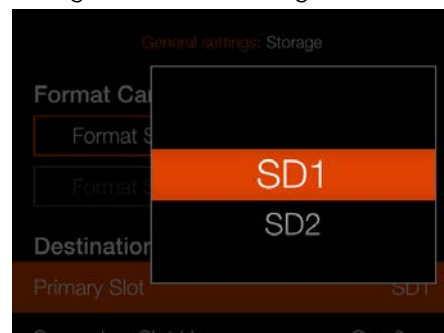

Storage usage setting

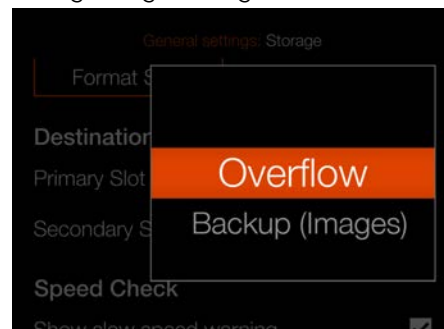

SOUND

Main menu

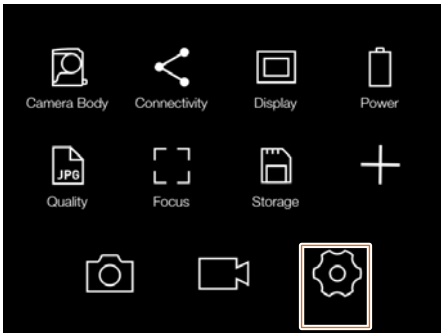

MAIN MENU > GENERAL SETTINGS > SOUND

- 1 Press the general settings icon on the touch display.
- 2 The general settings menu appears.

Swipe right or press the Menu button to get back to the main menu.

General settings menu

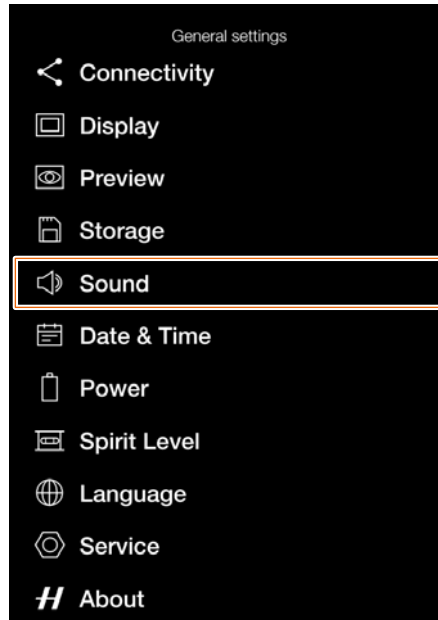

Sound settings menu

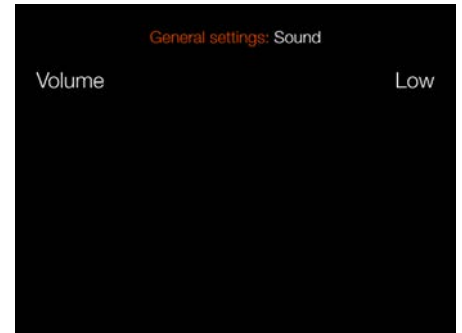

Sound settings:

Volume:

Select between:

- Off
- Low
- Medium
- High

Volume setting

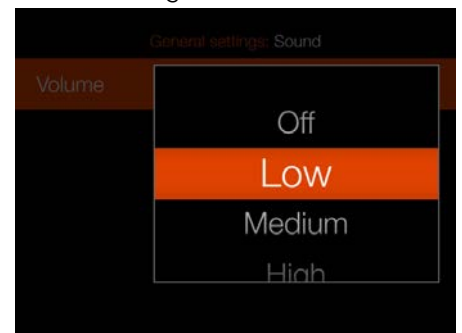

DATE & TIME

Main menu

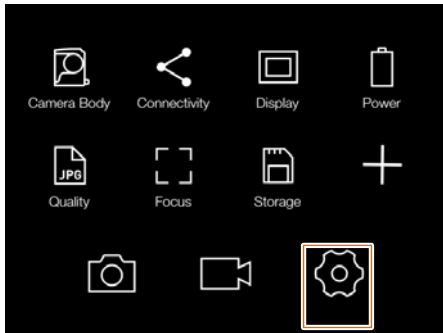

MAIN MENU > GENERAL SETTINGS > DATE & TIME

- 1 Press the general settings icon on the touch display.
- 2 The general settings menu appears.

Swipe right or press the Menu button to get back to the main menu.

Date & Time settings are explained on the next page.

General settings menu

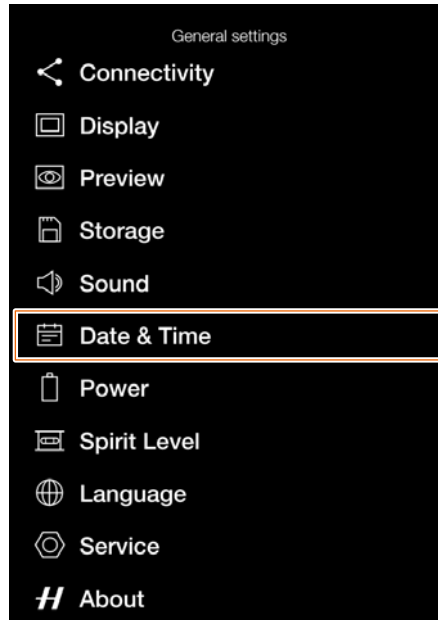

Date & time settings menu



DATE & TIME SETTINGS

MAIN MENU > GENERAL SETTINGS > DATE & TIME

- 1 Press the general settings icon on the touch display.
- 2 The general settings menu appears.
- 3 Press the date & time settings Menu.

Swipe right or press the Menu button to get back to the main menu.

Date & Time settings:

Date:

Tap Year, Month and day to bring up the setting.
Set current date as shown in (A)

Time:

Tap Hour and Minute to bring up the setting.
Set current time as shown in (B)

Date & time settings menu



Year setting



Month setting



Day setting



Hour setting



Minute setting



POWER

Main menu

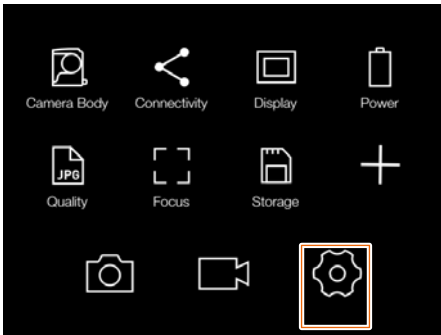

MAIN MENU > GENERAL SETTINGS > POWER

- 1 Press the general settings icon on the touch display.
- 2 The general settings menu appears.

Swipe right or press the Menu button to get back to the main menu.

Power settings are explained on the next page.

General settings menu

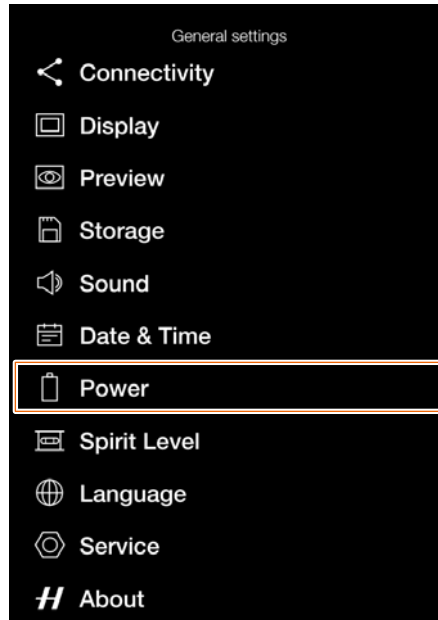

Power settings menu

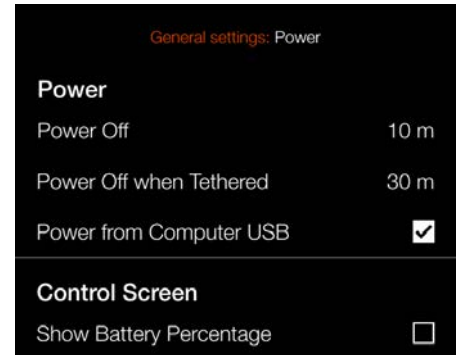

POWER SETTINGS

MAIN MENU > GENERAL SETTINGS > POWER

- 1 Press the general settings icon on the touch display.
- 2 The general settings menu appears.
- 3 Press the power settings menu.

Swipe right or press the Menu button to get back to the main menu.

Power settings:

Power Off:

Select between:

- 5 min
- 10 min
- 30 min
- Never

Power Off when Tethered:

Select between:

- 5 min
- 10 min
- 30 min
- Never

Control Screen settings:

Show Battery Percentage:

When this box is checked, an approximate percentage value for remaining battery capacity is shown next to the battery symbol.

Power settings menu

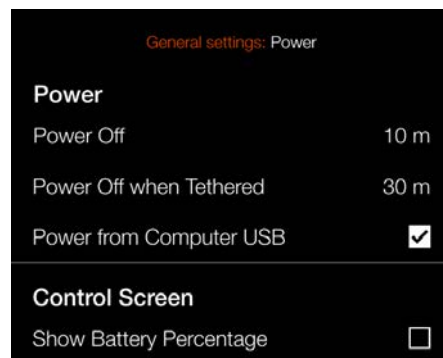

Power off setting

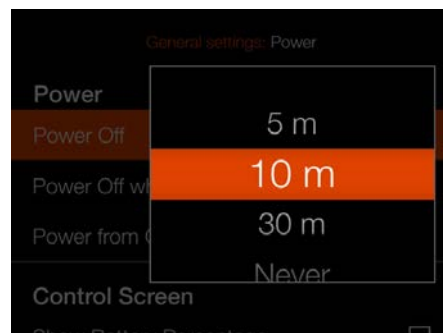

Power off when tethered setting

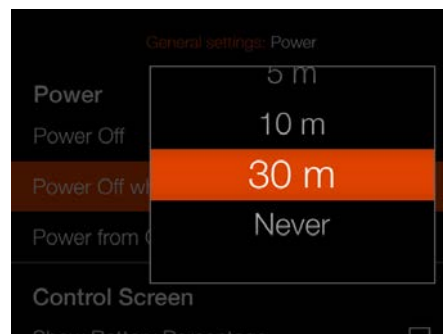

Percent value activated

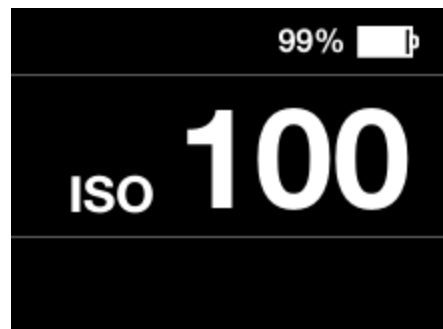

SPIRIT LEVEL

Main menu

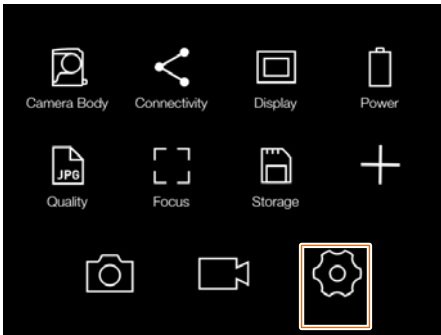

MAIN MENU > GENERAL SETTINGS > SPIRIT LEVEL

- 1 Press the general settings icon on the touch display.
- 2 The general settings menu appears.

Swipe right or press the Menu button to get back to the main menu.

Note!

You can also bring up the spirit level overlay in live view mode by pressing the Display button until it is shown.

General settings menu

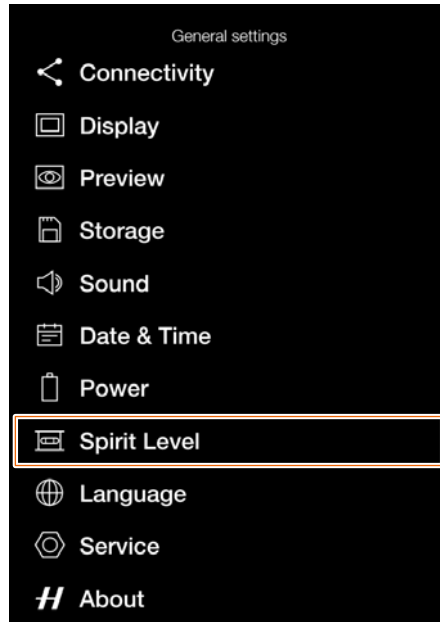

Spirit level when camera is aligned

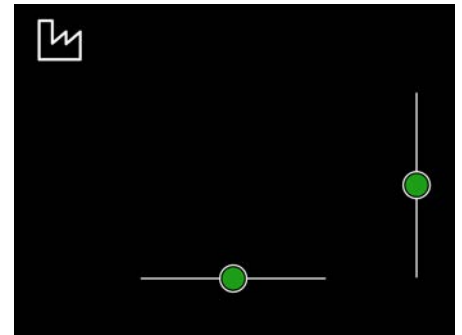

Spirit level when camera is tilted a little to the right and more down.

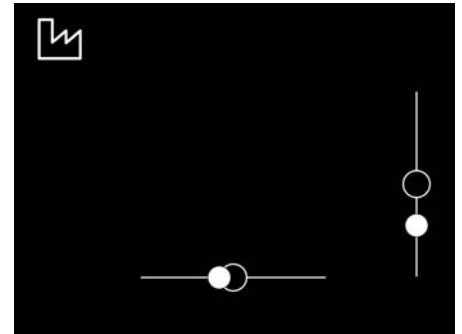

Camera tilted to the left.



Camera aligned horizontally.



Camera tilted to the right.



Camera tilted up.



Camera aligned vertically.



Camera tilted down.



CALIBRATE SPIRIT LEVEL

MAIN MENU > GENERAL SETTINGS > SPIRIT LEVEL

The spirit level can be set to factory or user mode. In user mode, the spirit level can be calibrated by the user. This can be used if you have a specific camera position that you want to return to. In factory mode, the calibration from the factory is used.

 Factory mode with factory settings.

 User mode with user settings.

How to calibrate the spirit level

- 1 Press the general settings icon on the main menu display.
- 2 The general settings menu appears.
- 3 Press the spirit level icon.
- 4 Press the icon in the top left corner **(A)**.
- 5 The spirit level dialogue appears.
- 6 Align the camera carefully both horizontally and vertically.
- 7 Press Calibrate **(B)**.
- 8 The two white circles are now moved to their centre position. When in their centre position, they turn green.

Swipe right or press the Menu button to get back to the main menu.

How to reset spirit level to factory calibration

- 1 Press the general settings icon on the main menu display.
- 2 The general settings menu appears.
- 3 Press the spirit level icon.
- 4 Press the icon in the top left corner **(A)**.
- 5 The spirit level dialogue appears.
- 6 Press the factory settings icon **(C)**.
- 7 The factory settings icon **(D)** is now displayed and the Spirit Level is reset to factory calibration settings.

Swipe right or press the Menu button to get back to the main menu.

General settings menu

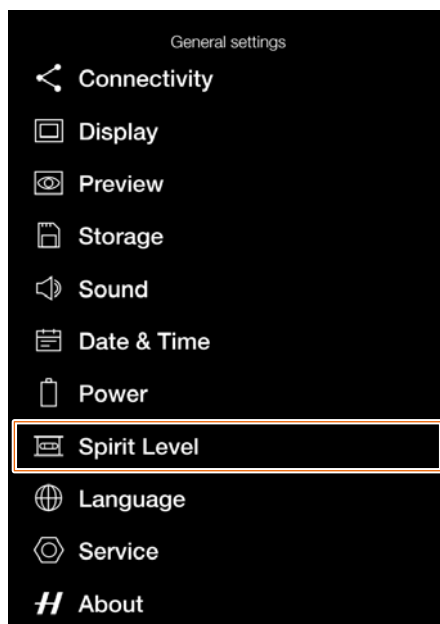

Spirit level when camera is aligned

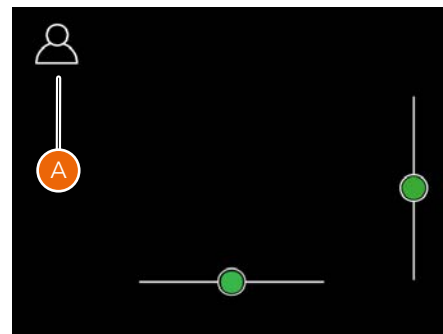

Spirit level when camera is tilted a little to the right and more down.

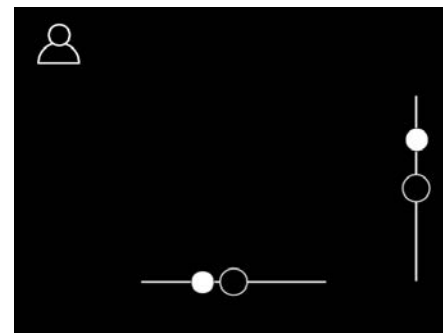

Spirit level when calibrated by user.

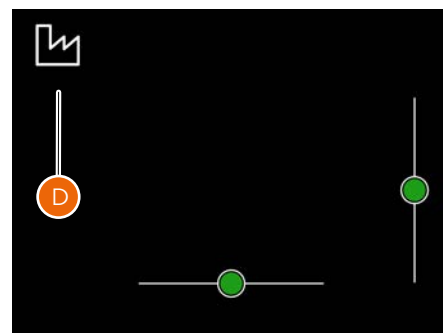
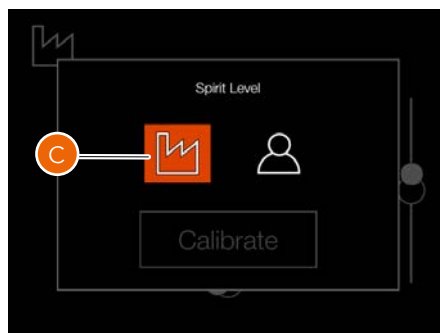
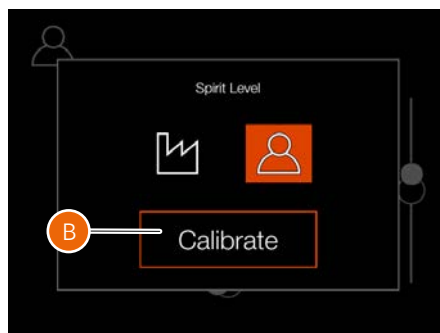
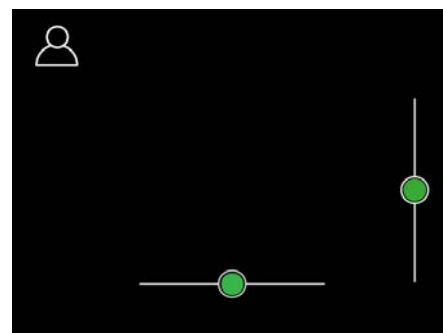

LANGUAGE

Main menu

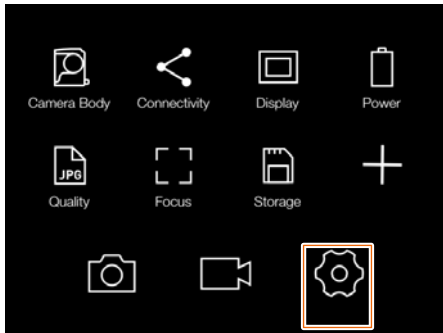

MAIN MENU > GENERAL SETTINGS > LANGUAGE

- 1 Press the general settings icon on the touch display.
- 2 The general settings menu appears.

Swipe right or press the Menu button to get back to the main menu.

General settings menu

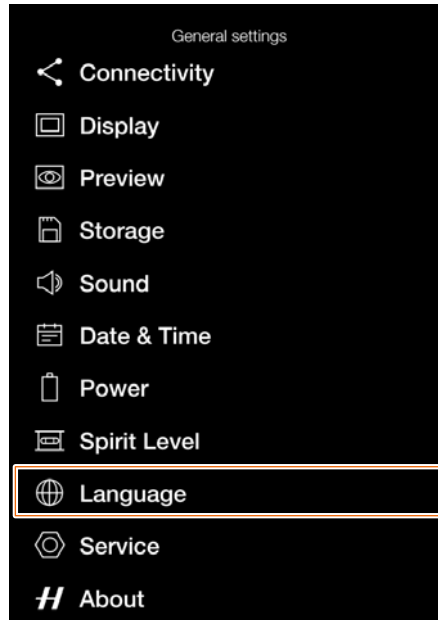

Language settings menu



Language settings:

Select between:

- English
- Spanish
- French
- German
- Italian
- Swedish
- Russian
- Japanese
- Chinese (simplified)
- Chinese (traditional)
- Korean

Language setting



SERVICE

Main menu

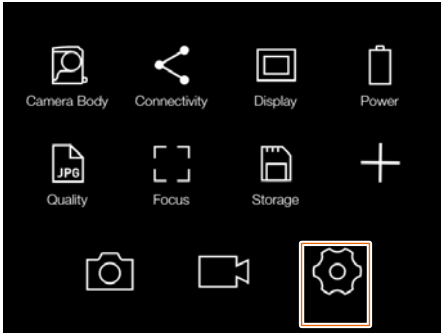

MAIN MENU > GENERAL SETTINGS > SERVICE

- 1 Press the general settings icon on the touch display.
- 2 The general settings menu appears.

Swipe right or press the Menu button to get back to the main menu.

Service settings are explained on the next page.

General settings menu

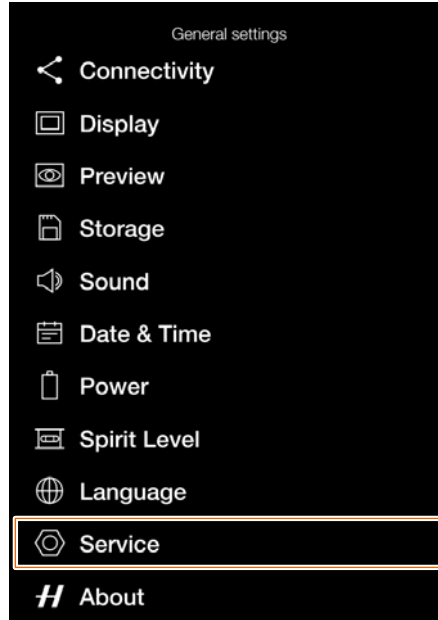

Service settings menu

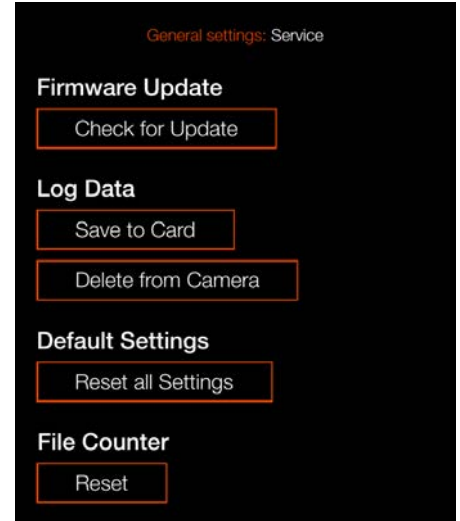

SERVICE SETTINGS–FIRMWARE UPDATE

MAIN MENU > GENERAL SETTINGS > SERVICE

- 1 Press the general settings icon on the touch display.
- 2 The general settings menu appears.
- 3 Press the service settings menu.

Swipe right or press the Menu button to get back to the main menu.

Update firmware procedure

- 1 Download the latest firmware from www.hasselblad.com.
- 2 Save the firmware file to a SD Card.
- 3 Insert the SD Card in the CFV.
- 4 Select Settings from the main menu.
- 5 Select Service / Firmware Update / Check for Update.
- 6 Make sure the firmware file name and number corresponds to the latest firmware file you have downloaded.
- 7 Select Update.
- 8 Select Update in the Update Dialogue to start the firmware update.
- 9 During the update the text **Update in progress** is displayed on the Display.
- 10 Do not turn off the CFV during the update progress.
- 11 The Update will take several minutes.
- 12 When the update is finished this text will be displayed: **Update is completed.**
- 13 The new firmware is now installed!

Service settings menu

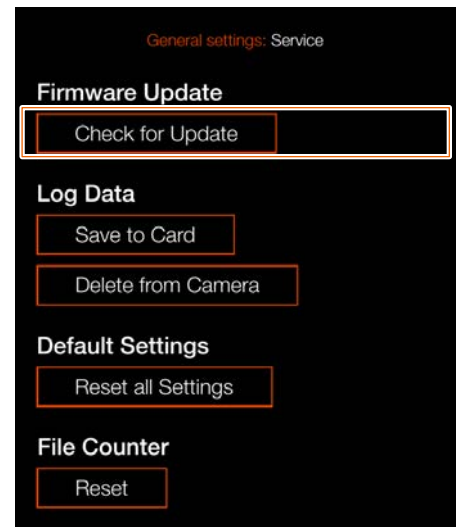

Check for update

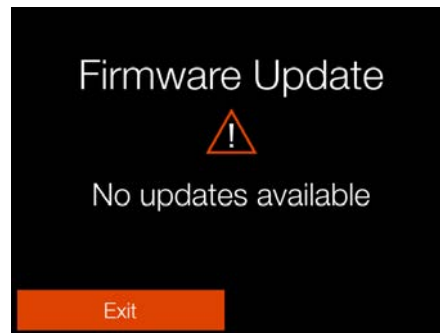

Firmware update dialogue when no firmware updates are available.

Firmware update



Firmware update dialogue when two firmware updates are available.

Update dialogue

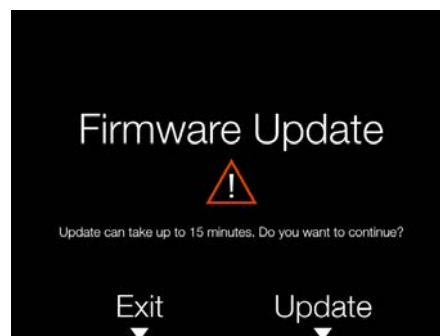

Firmware update confirm dialogue to continue update process. The update can take up to 15 minutes. Select **Update** or **Exit**.

Update in progress



SERVICE SETTINGS—SAVE LOG

MAIN MENU > GENERAL SETTINGS > SERVICE

- 1 Press the general settings icon on the touch display.
- 2 The general settings menu appears.
- 3 Press the service settings menu.

Swipe right or press the Menu button to get back to the main menu

Log Data contains useful information for the Hasselblad service centre when errors have occurred.

How to save Log Data:

- 1 Press the Menu button.
- 2 Navigate to general settings.
- 3 Navigate to Service.
- 4 Navigate to Log Data.
- 5 Press the **Save to Card** button.
- 6 Save Log Data saves a log file on the active card.
- 7 Press the Menu button to exit.

How to delete Log Data:

- 1 Press the Menu button.
- 2 Navigate to general settings.
- 3 Navigate to Service.
- 4 Navigate to Log Data.
- 5 Press the **Delete from Camera** button.
- 6 In the dialogue choose **Exit** or **Delete** with the Cross or Rectangle buttons.
- 7 Press the Menu button to exit.

Service settings menu

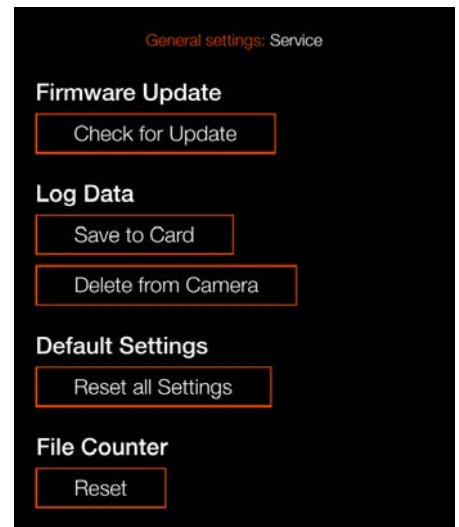

Save log data

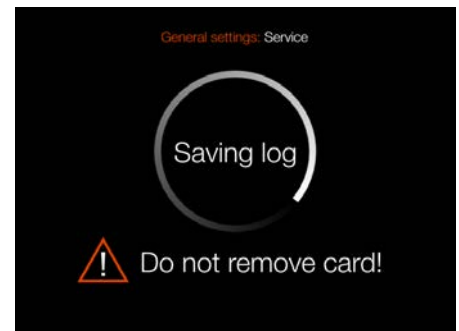

Delete log data dialogue

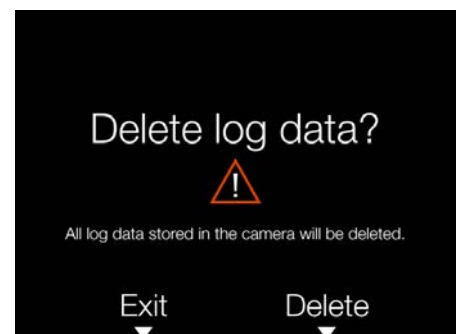

SERVICE SETTINGS—RESET SETTINGS

MAIN MENU > GENERAL SETTINGS > SERVICE

- 1 Press the general settings icon on the touch display.
- 2 The general settings menu appears.
- 3 Press the service settings menu.

Swipe right or press the Menu button to get back to the main menu.

Reset Settings is a function that is used to reset all settings in the CFV to factory default.

How to reset settings:

- 1 Press the Menu button.
- 2 Navigate to General Settings.
- 3 Navigate to Service.
- 4 Navigate to Default Settings.
- 5 Press the **Reset all Settings** button.
- 6 In the dialogue choose Exit or Reset with the Cross or Rectangle buttons.
- 7 Press the Menu button to exit.

Service settings menu

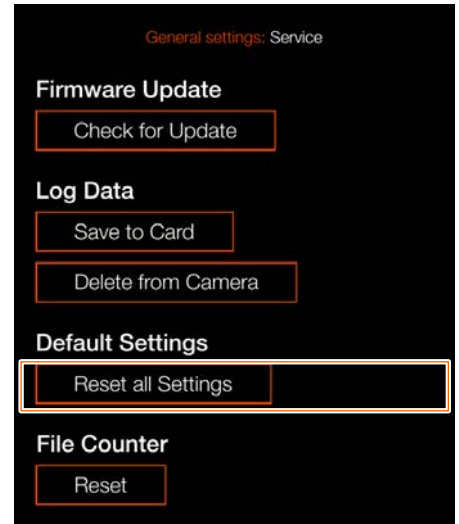

Reset settings

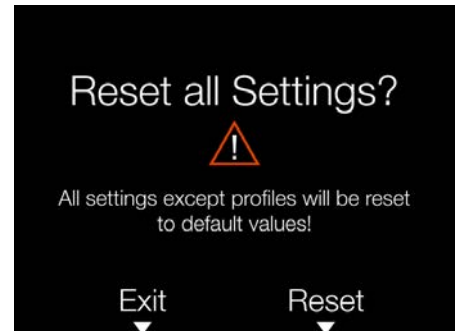

SERVICE SETTINGS—RESET FILE COUNTER

MAIN MENU > GENERAL SETTINGS > SERVICE

- 1 Press the general settings icon on the touch display.
- 2 The general settings menu appears.
- 3 Press the service settings menu.

Swipe right or press the Menu button to get back to the main menu.

Reset Settings is a function that is used to reset all settings in the CFV to factory default.

How to reset the file counter:

- 1 Press the Menu button.
- 2 Navigate to general settings.
- 3 Navigate to Service.
- 4 Under File Counter, select Reset.
A dialogue will appear asking for confirmation.
- 5 Press **Reset** (Rectangle button).
- 6 After confirmation, the file counter will be reset and the next captured image (or video recording) will be numbered B0000001.
- 7 If the current folder on the memory card is not empty when a Reset is performed, a new folder will be created on the memory card. This is done to avoid the possibility of two captured images (or video recordings) being labelled with the same name and file number.

Note!

A new folder is created if there are images present on the active SD memory card.

Service settings menu

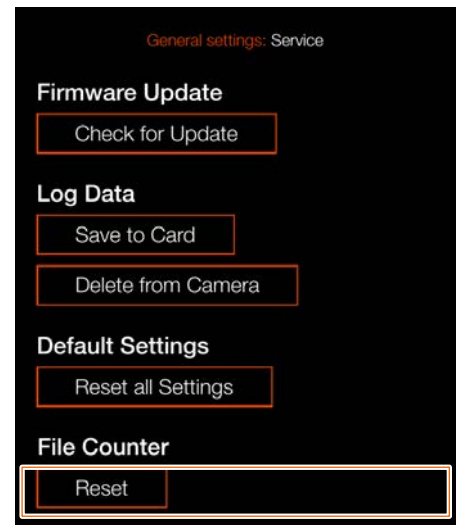

Reset file counter

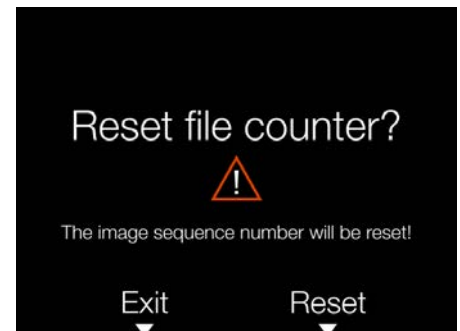

ABOUT

Main menu

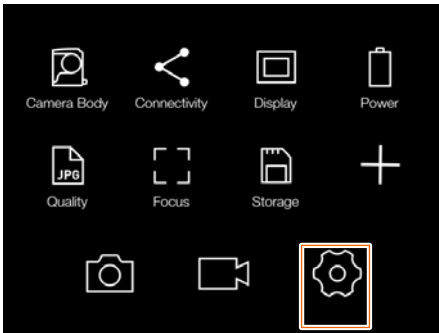

MAIN MENU > GENERAL SETTINGS > ABOUT

- 1 Press the general settings icon on the touch display.
- 2 The general settings menu appears.

Swipe right or press the Menu button to get back to the main menu.

General settings menu

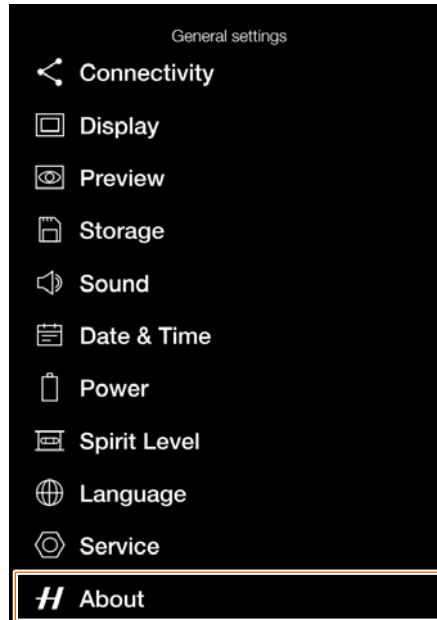

About settings menu

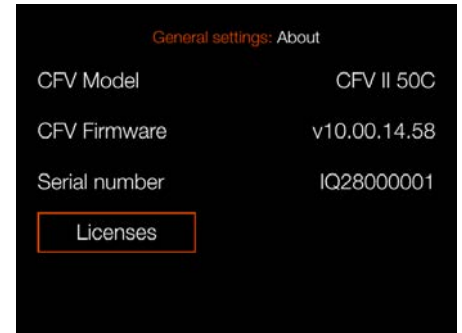

About settings:

Firmware

The About box will tell you which firmware version is present so you can see if you have the latest firmware (can be downloaded from the Hasselblad website).

Serial number

The serial number is also displayed in case Hasselblad Support needs to know it for problem solving.

Licenses

Displays the available licenses.

Licences menu

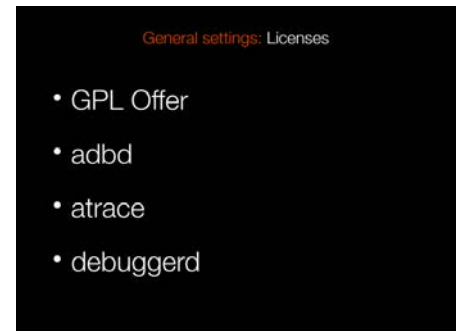

7.1 PHOCUS OVERVIEW

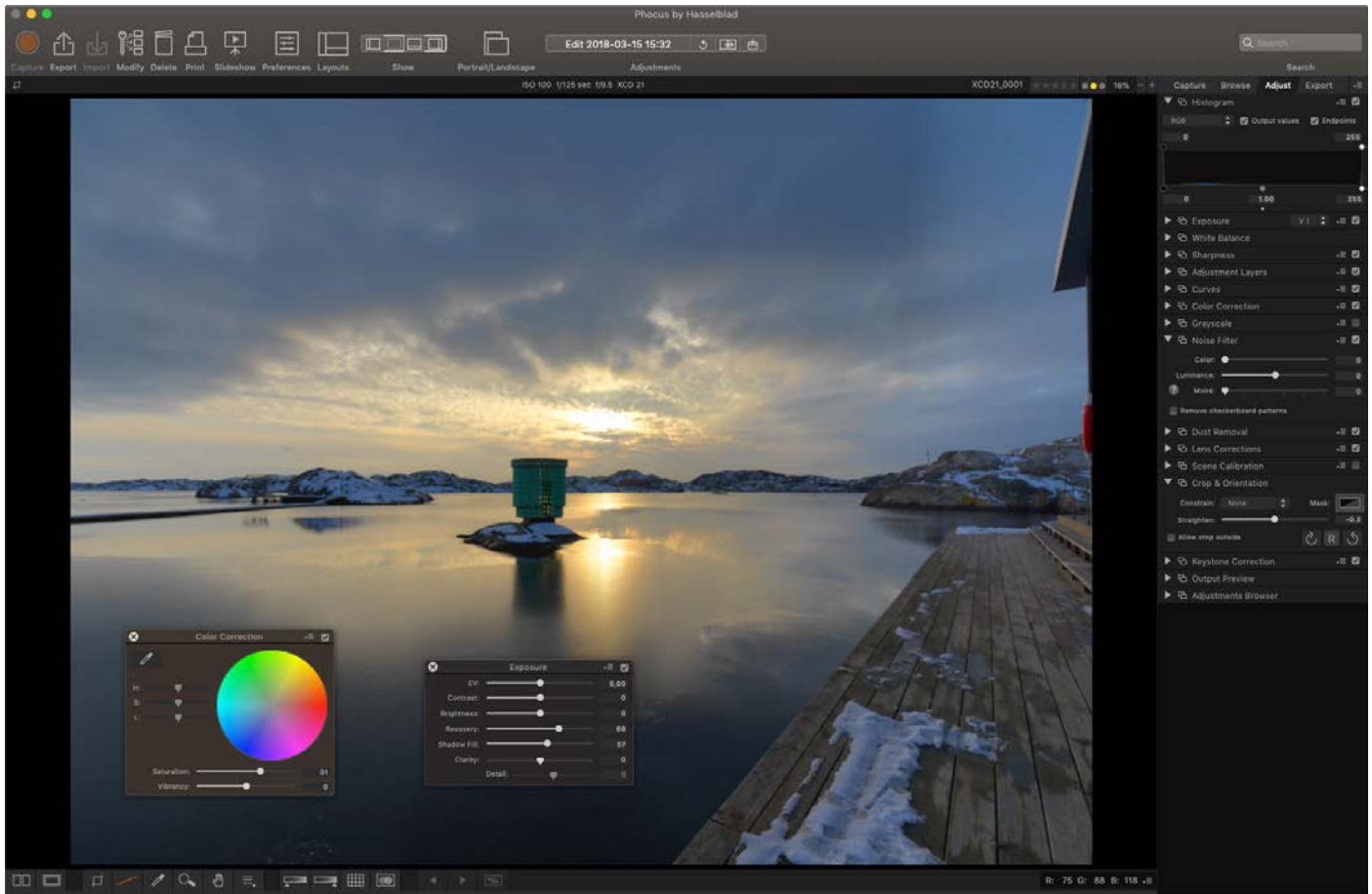

PHOCUS

Phocus is a professional image processing and file management application aimed primarily at Hasselblad RAW 3F file handling. Phocus is available license-free for both Mac and Windows.

The image processing engine in Phocus is optimized for Hasselblad RAW files. Ensuring the maximum quality from your images. Colours and image details are rendered with highest possible accuracy.

FEATURES IN PHOCUS

Phocus is feature-filled while still being easy to use, making it easy to achieve amazing results. Some of the powerful tools and features are:

Natural colours

The Hasselblad Natural Colour Solution (HNCS) enables you to produce outstanding and reliable colours so that skin tones, specific product colours, and difficult gradations reproduce beautifully every time without the need for multiple colour profiles.

Keystone perspective correction

The Keystone tool enables you to perform high quality perspective corrections directly in Phocus. This can be done both via a simple guideline interface or manual slider adjustments. Additionally, the dual-axis correction capability is extremely useful when copying flat artwork.

Local adjustments

A number of powerful adjustment tools can be used for local adjustments of the image, allowing for quick and precise corrections.

Digital lens correction

Modern lens design from Hasselblad has been optimised for digital perfection, including full correction of colour aberration, distortion and light fall off. Phocus makes use of

its detailed knowledge of the lens design and calculates the optical corrections for every shot at the given distance and aperture setting, providing perfect images, and an ideal basis for optimal image rendering and further processing. Hasselblad digital lens correction technology supports virtually all Carl Zeiss lenses from the classic Hasselblad V System, using manual settings.

Auto moiré detection

Phocus can now scan your images and automatically detect moiré interference patterns. You can choose to correct the interference globally or locally via the local adjustment tool.

Live view functionality - camera control

In tethered situations, Phocus allows for complete camera remote control, including exposure settings, focusing and mirror control. The ability to have live view greatly simplifies tasks such as composing and focusing.

Note!

Read the dedicated user guide for Phocus which can be downloaded from www.hasselblad.com.

Note!

Phocus is a license free software with unlimited installations and there is no registration needed.

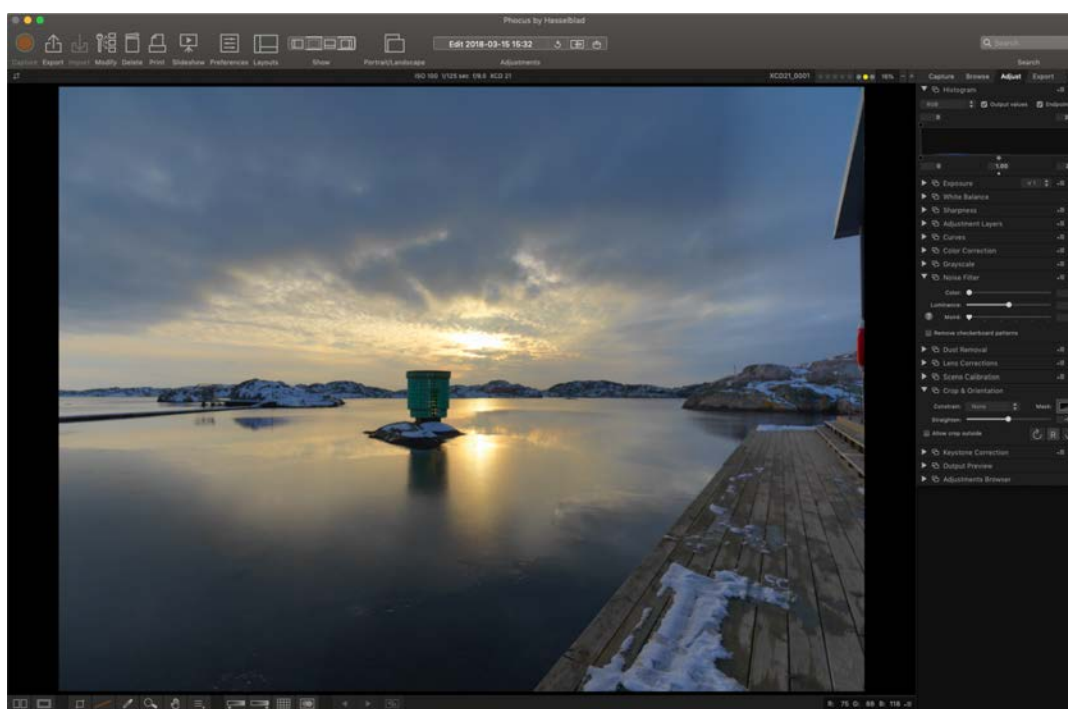

PHOCUS MOBILE 2

Phocus Mobile 2 is the successor to the original Phocus Mobile iOS application adding a number of new features. Most importantly it adds support for both USB and Wi-Fi connectivity, will let you capture images directly to the iOS device and provides full quality image editing and export. It will support both iPhone and iPad but for the image editing functionality an iPad Pro or one of the most recent iPad Air models with more than 2GB RAM is required. It will support the CFV II 50C and 907X as well as the X1D II 50C cameras and future models - the original Phocus Mobile will still be needed for the older cameras.

Note!

The CFV II 50C, 907X and X1D II 50C cameras are not compatible with the original Phocus Mobile app.

For further details please refer to hasselblad.com/phocusmobile2.

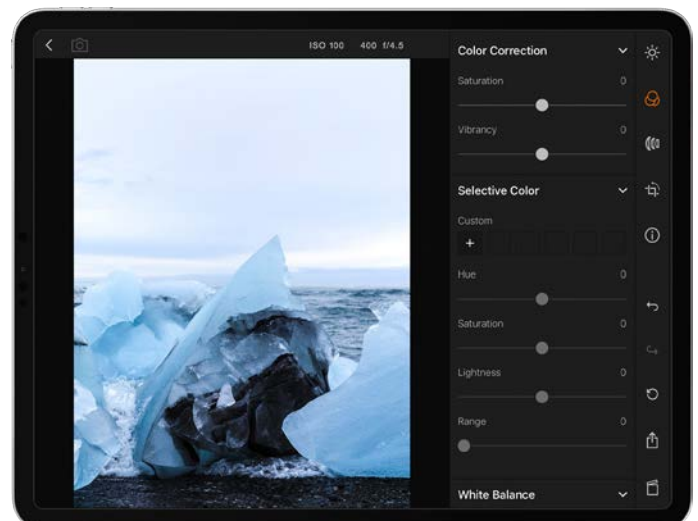
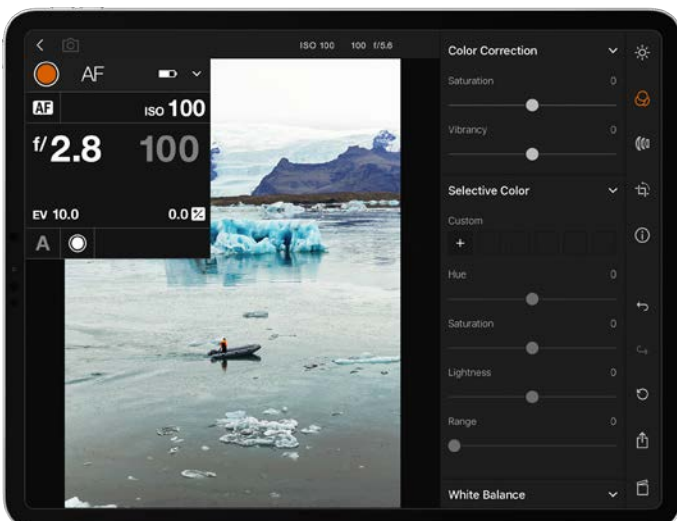
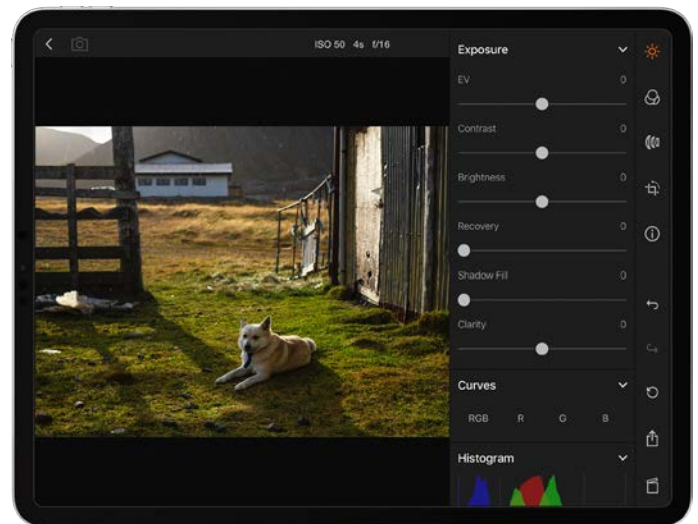
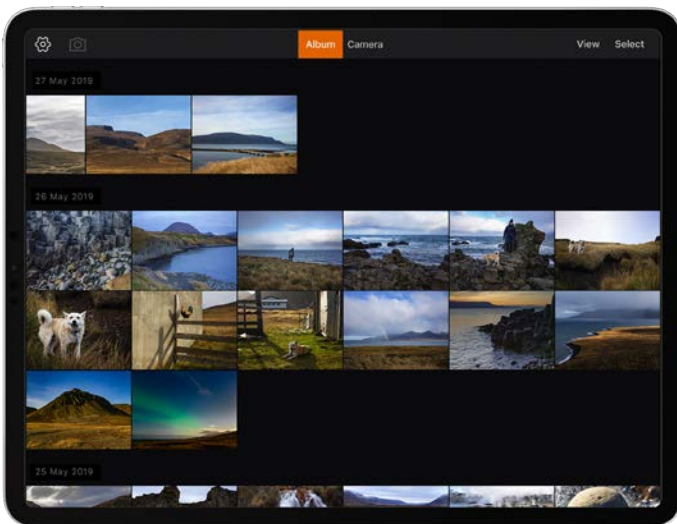

7.2 CONNECT TO A COMPUTER

- 1 Connect a USB 3 cable to the USB port on the computer.
- 2 Connect the USB 3 cable to the USB port on the camera.

When initiating a shot from Phocus, the computer sends a signal to the camera, which triggers the shutter (and strobe/flash, if any). The camera then sends the capture over the USB connection to the computer, where it is displayed on the computer screen and saved as a 16-bit 3F file in the currently selected folder on the computer hard disk.

Note!

When connected to a computer, the following applies:

- The destination medium and location are controlled from Phocus.
- All exposure settings, including ISO, aperture and exposure time, are controlled from Phocus if you choose to expose from Phocus. In addition extra tools such as live video, remote focus control are available. See Phocus user manual for full description.

Note!

Make sure the Tethering mode is set to Mac/PC when connecting to a computer. See more on page 84.

7.3 CONNECT TO AN IPAD PRO

USING CABLE

Tethered shooting via a USB cable, is available with an iPad Pro running Phocus Mobile 2 when using Wi-Fi and cable connections. A cable connection can be made through the USB-C port or when using a Lightning to USB 3 adapter. A USB-C to Lightning cable will also work, but will only give USB 2 speed.

Connect a USB-C to C cable from the camera to the iPad and start the Phocus Mobile 2 App. See more on the next page.

Note!

Make sure the Tethering mode is set to iOS when connecting to an iPad using USB. See more on page 84.

When the camera is connected via Wi-Fi to the iPad Pro, both tethered capture and camera control are supported.

USING WI-FI

Connect the iPad using the procedure described on page 109.

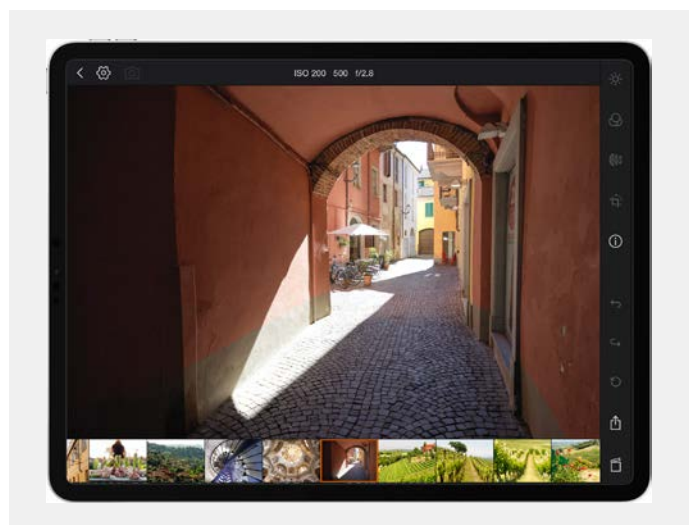
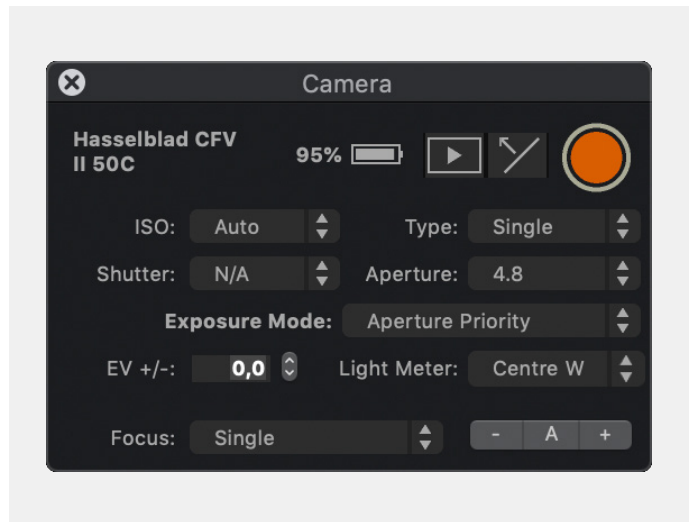

7.4 CONNECT THE CAMERA TO AN IPAD PRO OVER WI-FI

The following assumes that Phocus Mobile 2 is installed on a compatible iPad (iPad Pro or iPad Air 2019). It is available as a free download from the Apple App Store.

Two methods are available to connect the iPad to the camera.

BLUETOOTH ASSISTED WI-FI CONNECTION

- 1 Make sure that Bluetooth is activated on the iPad.
- 2 Start Phocus Mobile 2 on the iPad.
- 3 Start the camera and activate Wi-Fi **(A)**.
- 4 In Mobile 2, go to the Camera Tab **(B)**.
- 5 Mobile 2 starts to search for cameras. When finished, a list of available cameras will be shown **(C)**.
- 6 Select your camera from the list.
- 7 If this is the first time the camera is connected to this iPad, the camera will show the dialogue **(D)** to confirm the connection. Press the Rectangle Button (□) to confirm the connection. If you want to deny the connection request, press the Cross Button (×).
- 8 The iPad will show the dialogue **(E)**.
- 9 If you confirm the connection request, the camera will automatically send the Wi-Fi password (shown in the Connectivity menu) to the iPad. To confirm this connection, you will have to tap Join in the dialogue **(F)** that appears on the iPad.
- 10 When the connection is established, the Camera Icon in the upper left corner of the App window will change from grey to white **(G)**.

Note!

This process is simplified when a camera has been previously connected to this iPad. Then only steps **(A)**, **(B)** and **(F)** are required.

Also see page 84.

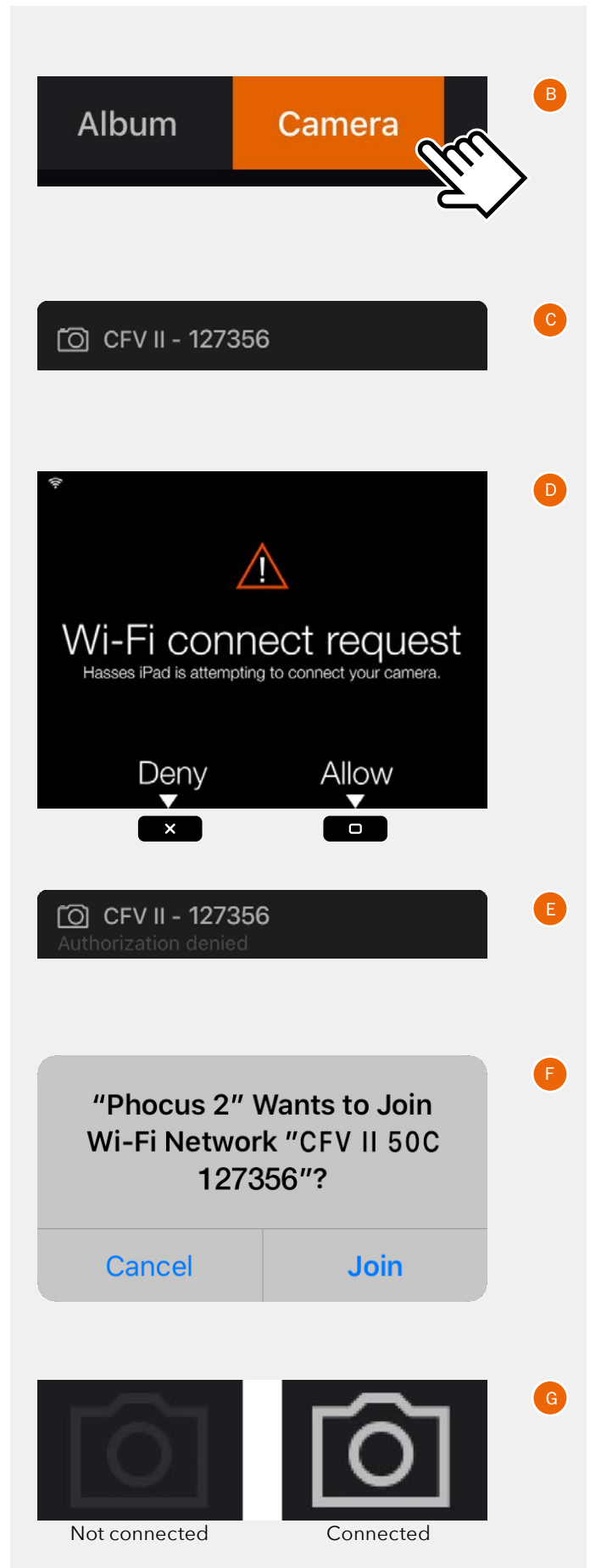
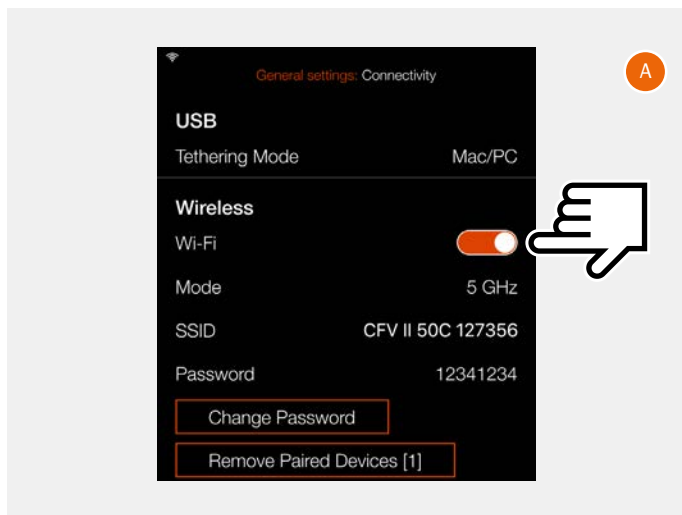

MANUAL WI-FI CONNECTION

- 1 Start the camera and activate Wi-Fi **(A)**. The camera will now create a Wi-Fi network with the same name as the SSID **(1)**.
- 2 Enter the settings on the iPad by tapping the Settings Icon. 
- 3 In the iPad settings dialogue, tap "Wi-Fi" **(B)**.
- 4 In the list "My Networks" or "Other Networks" you will find the camera network. Tap on it to connect **(C)**.
- 5 If the camera has not previously been connected to this iPad, a password dialogue will appear on the iPad **(D)**.
- 6 Enter the camera password **(2)**.
- 7 When the camera network is shown directly under Wi-Fi **(E)** a connection is established.
- 8 Start Phocus Mobile 2 on the iPad.

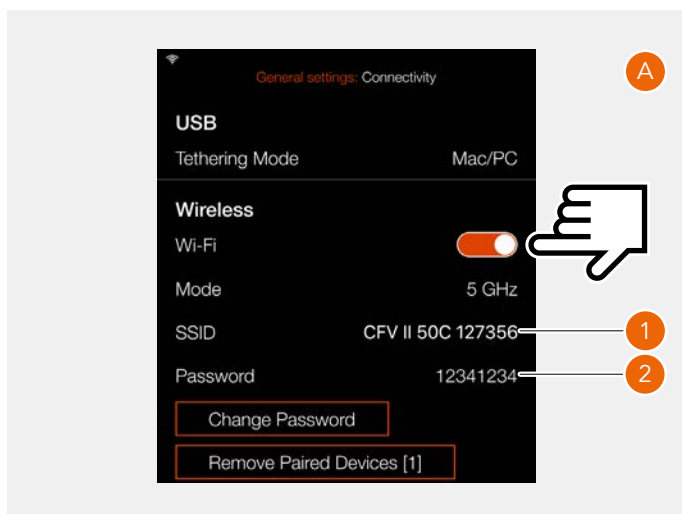
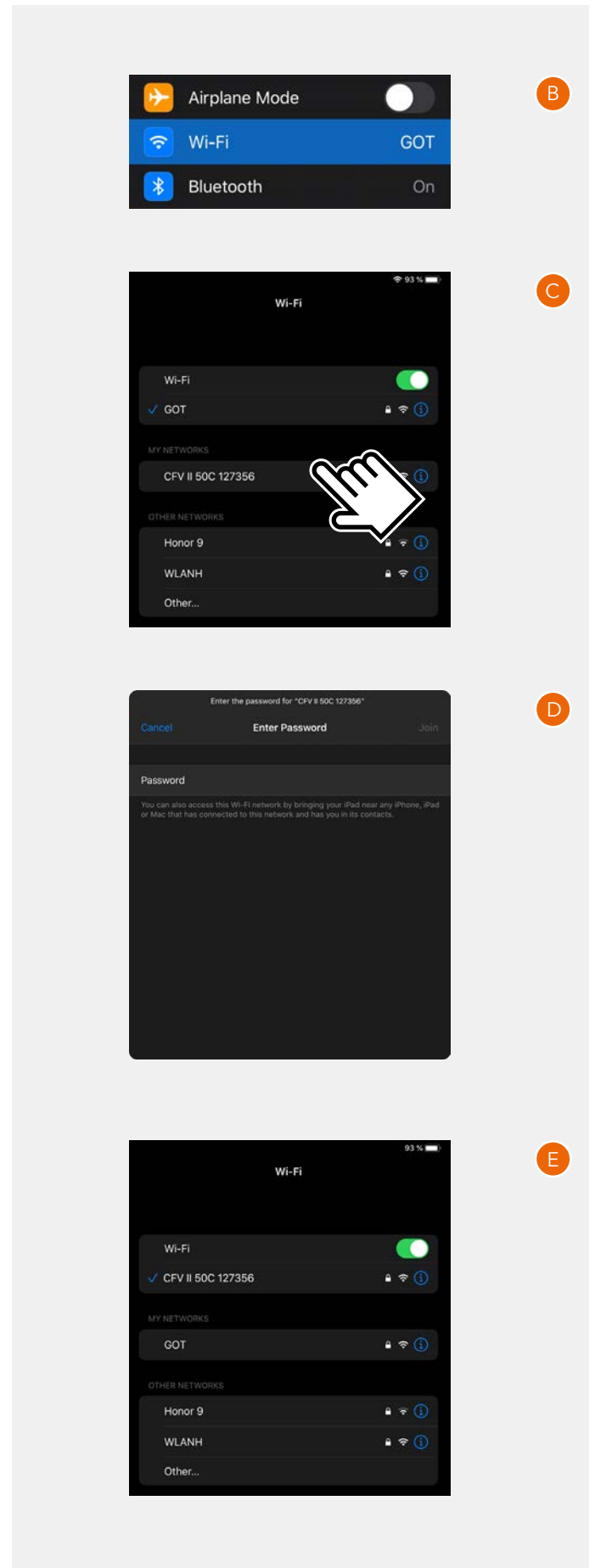

7.5 PHOCUS AND HASSELBLAD CAPTURE FILES

Images captured by the camera are stored as Hasselblad RAW format files or JPEG format. It is possible to store either RAW or JPG or both RAW and JPG simultaneously.

Hasselblad RAW files are initially stored in the 3FR format which is a proprietary Hasselblad format for the temporary storage of captures. A 3FR file contains the complete digitized raw image exactly as it was captured by the camera. 3FR information requires further computing power (typically by way of Phocus) to obtain complete development. If developed in Phocus, 3FR files become Hasselblad 3F files - denoted by each file now bearing the suffix ".fff". If developed by other RAW processors, the 3FR files are not converted to 3F but can be exported directly to TIFF and PSD according to requirements.

When working tethered to Phocus or Phocus Mobile 2, 3FR files are automatically processed and stored in the background on a computer appearing as 3F files on the hard disk ready for selective adjustment and export. 3FR files stored on a SD card can be processed using:

- Hasselblad Phocus
- Adobe Camera Raw
- Adobe Lightroom

Capture files can be stored for future use as 3FR files (from a SD card) for later processing in Phocus or other software, or they can be stored as 3F files (as a result of tethered shooting or 3FR files processed and converted in Phocus). In all cases if you keep the original 3FR/3F files, you will also retain the possibility of reprocessing them in the future in later versions of Phocus or other software to take advantage of eventual improvements and developments.



8.1 ACCESSORIES

RECHARGEABLE BATTERY

No. CP.HB.00000238.01

Powerful rechargeable Li-ion battery. 3400 mAh, 24.7 Wh

BATTERY CHARGING HUB

CP.HB.00000397.01 (EMEA)

CP.HB.00000395.01 (United Kingdom)

CP.HB.00000392.01 (North America/Japan)

CP.HB.00000396.01 (China)

CP.HB.00000393.01 (South Korea)

CP.HB.00000394.01 (Australia/New Zealand)

Streamlining the battery charging process, the Hasselblad battery charging hub contains dual slots that support the simultaneous charging of two batteries. An integrated USB Type-C connector supports mains power via an included power supply or from common external USB battery banks (sold separately). Front-facing LEDs indicate status and capacity when charging, or users can use the battery charging hub to check battery levels simply by inserting a battery and pressing a single button.

FLASH SYNC INPUT CABLE

No. CP.QT.HB000184.01

This cable is used to connect the flash sync of a lens to the CFV for exposure synchronization.

FLASH SYNC OUTPUT CABLE

No. CP.QT.HB000182.01

For connection of an external flash to the flash sync output of the CFV.



EXPOSURE CABLE EL

No. CP.QT.HB000183.01

Cable for exposure remote control of an EL type camera using Phocus. Not required for 555ELD.

EXPOSURE CABLE 503

No. CP.QT.HB000181.01

Cable for exposure remote control of a 503CW camera with Winder CW using Phocus.

RELEASE CORD X

CP.HB.00000242.01

The Hasselblad Release Cord X allows for remote shutter control in Electronic Shutter mode on the CFV II 50C, helping to eliminate shake or vibration. A durable cloth-wrapped 90cm (36 in.) cable connects to the microphone input of the CFV II 50C and the simple single button operation allows photographers to keep vibration to a minimum. Its durable metal construction combined with its slim, ergonomic design fits comfortably in the hand. Release Cord X comes with a small leather carry pouch.



9.1 CLEAN THE SENSOR FILTER

Caution!

Be careful when you attach/remove the components to/from the camera. This will help prevent damage to the data bus connections.

Caution!

When you remove the CFV from the camera, keep foreign objects away from the sensor as the green IR filter is very sensitive. This will help prevent damage to the equipment.

Caution!

If you use canned compressed air to clean the glass of IR filter, read the instructions very carefully before use. This will help prevent damage to the filter.

Clean the Sensor

- 1 Remove USB 3 cable if connected.
- 2 Remove the CFV from the camera by sliding the Lock Button to the right (when seen from behind). See page 18.
- 3 Clean the rear part of the camera carefully by using compressed air.
- 4 Carefully clean the outside surface of IR filter by using clean compressed air.
- 5 Reattach the CFV to the camera or use the protective cover as quickly as possible.

If compressed air did not remove all the problems and you still see dust spots in the images, you may have dust either on the inside of the IR filter or on the CMOS sensor itself, please contact your Hasselblad dealer.

9.2 CLEAN THE LENS GLASS SURFACE

REMOVE DUST

Caution!

Do not touch the glass surface with your fingers. This can cause damage to the equipment.

If there is dust on the lens glass, do as follows:

- 1 Remove the dust with an air blower.
- 2 If that does not solve the problem, try to remove dust with a very soft lens brush.

REMOVE SMEAR

Caution!

Do not touch the glass surface with your fingers. This can cause damage to the equipment.

If there is smear on the lens glass, do as follows:

- 1 If you are not sure how to remove the smear, contact your local Hasselblad authorized service centre.
- 2 Clean the lens glass with a high quality lens cleaning solution on a tissue.

9.3 CHANGE FROM FOREIGN LANGUAGE

MAIN MENU > GENERAL SETTINGS
> LANGUAGE

- 1 Press the general settings icon on the touch display **(A)**.
- 2 The general settings menu appears.
- 3 Navigate to the menu item with a globe icon.
- 4 Tap the text to the right **(B)**.
- 5 Scroll down to select your language.

Swipe right or press Menu button to get back to main menu.

General Settings Menu

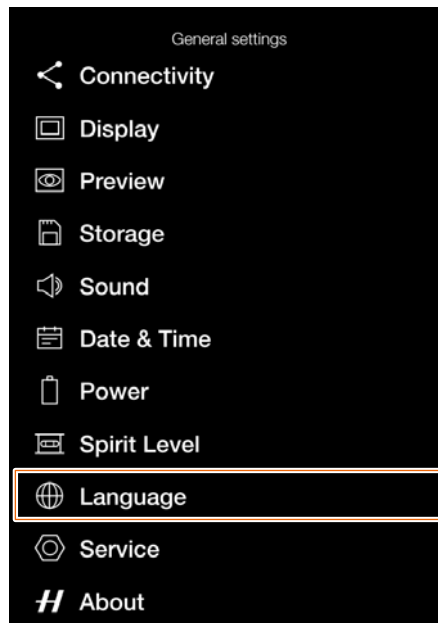

Language Settings Menu



Language Setting



9.4 ERROR MESSAGES

If any error message is displayed

- 1 Remove the components from the camera.
- 2 Attach the components to the camera again.

If the error message is still displayed

- 1 Remove the battery.
- 2 Wait 10 seconds.
- 3 Attach the battery again.
The camera processor is now reset.

If the error message is still displayed

- 1 Write down the error message.
- 2 Contact your closest authorized Hasselblad dealer.

9.5 INFORMATION ABOUT THE CFV II 50C USER GUIDE

The information in this user guide is intended for informational use only. The information and the 3D Product Images and Photos, are subject to change without notice, and should not be construed as a commitment by Victor Hasselblad AB.

UPDATES

Updates to this user guide will be issued regularly. Please check www.hasselblad.com for the latest version. If you are a registered user, you will get mail notifications when a new version is available.

3D PRODUCT IMAGES

The product Images in this user guide were not taken with a Hasselblad camera. They are produced in 3D as visualization. They are used for illustrative purposes only and are not intended to represent the image quality produced by Hasselblad cameras.

TRADEMARKS

Hasselblad, Phocus, Phocus Mobile and Phocus Mobile 2 are trademarks of Victor Hasselblad AB.

Adobe and Adobe Photoshop are trademarks of Adobe Systems, Inc. Macintosh, Mac OS, iPhone®, iPad® and iPod Touch® are trademarks of Apple.

Sandisk, Panasonic, Toshiba and Sony are trademarks of their respective corporations.

COPYRIGHT

All text in this user guide copyright © Victor Hasselblad AB. All images in this user guide, not credited to a specific photographer, copyright © Victor Hasselblad AB. The text, or parts of the texts, in this manual cannot be reprinted or reused without the written express permission of Victor Hasselblad AB.

The images in this user guide cannot be reprinted or reused without the written express permission of the photographers who owns the copyright.

Victor Hasselblad AB assumes no responsibility or liability for any errors or inaccuracies that may appear in this user guide. Victor Hasselblad AB assumes no responsibility or liability for loss or damage incurred during, or as a result of using Hasselblad software or products.

Copyright © 2020 Victor Hasselblad AB. All rights reserved.