

- MARKING AVAILABLE**
1. WATER.
 2. SEWER.
 3. WITHOUT MARKING.

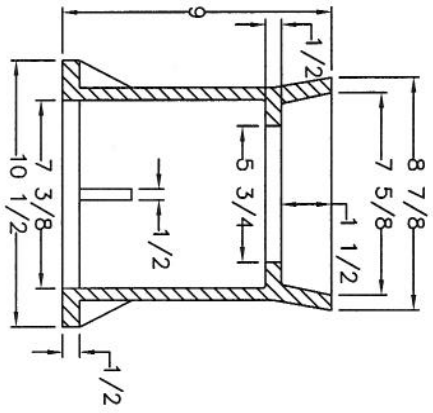
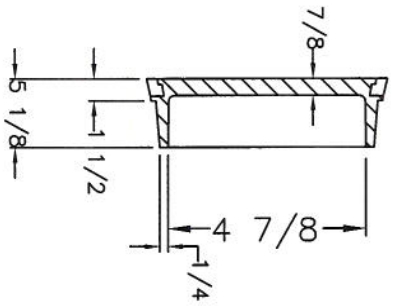

PART NO:	DESCRIPTION:	WEIGHT
115701	SAN Antonio Lid Water	15 Lbs
115702	SAN Antonio Lid Sewer	15 Lbs
115705	S.A VBX Extension 9"	28 Lbs
115710	S.A BASE	50 Lbs

SA-3 VBX #71 COMPLETE EQ V8490-3

AccuCast

415 S. 21st. STREET
WACO, TX 76706
Phone 1-254-756-3200
Fax 1-254-756-0200
Watts 1-800-433-6885

DRAWN BY: P S
DATE: 01/10/11
APPROVED:
REVISION:
SCALE: NOT TO SCALE
LOAD RATING HEAVY DUTY
MATERIAL SPECIFICATION GREY IRON ASTM A48 CL 30B
COATING BITUMINOUS TAR COATED (UNCOATED ON REQUEST)
ESTIMATED WEIGHT - LBS. •
PART / DWG NUMBER
CATALOG NUMBER
SEE TABLE