

Element Filters

OPAL ELEMENT FILTERS

NEW



The Opal's durable screw on lid is designed for quick and easy access to the element for cleaning and general maintenance. Constructed as a "one piece" housing from high impact polypropylene, the Opal has a maximum working pressure rating of 29 psi.

- 2" Quick connect unions for both ports.
- 100% polyester fabric 30 micron element.
- Pressure gauge and air relief valve standard with each unit.
- Special screw on lid for easy access to the filter.

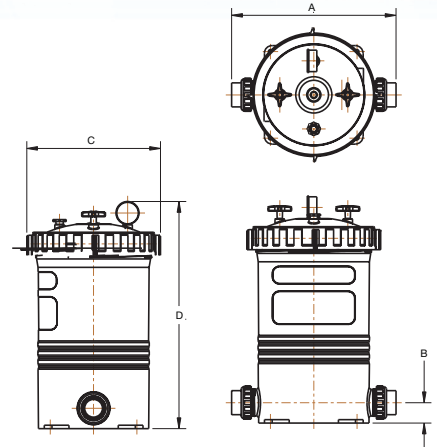

Model	A	B	C	D
Opal 120	19"	2.4"	15.5"	26.3"
Opal 150	19"	2.4"	15.5"	26.3"
Opal 180	19"	2.4"	15.5"	26.3"
Opal 180	19"	2.4"	15.5"	26.3"

Model	Model Description	Media Capacity	Overall Height	Flow Rate	Shipping Weight
2171350	Opal Element Filter 120	135	25.6"	37.5	30
2171800	Opal Element Filter 150	180	25.6"	56.5	30
217225	Opal Element Filter 180	225	-	-	-
217270	Opal Element Filter 270	270	-	-	-

SLIMLINE ELEMENT FILTERS

NEW



The Slimline housing is constructed of a strong thermoplastic material which provides a 50psi rated working pressure for the unit. The durable screw on lid is designed for quick and easy access to the element for cleaning and general maintenance.

- 1 1/2" Threaded Ports for versatility of connection.
- Standard 100% Polyester fabric, 30 micron element.
- Built In, automatic air bleed system.
- All Nitrile rubber seals.
- Special screw on lid for easy access to the filter.

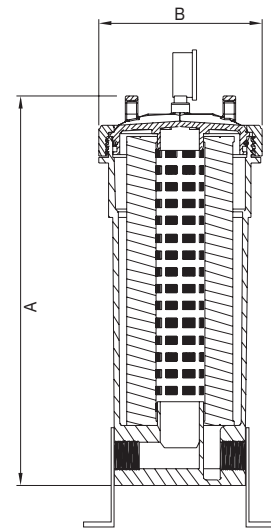

Model	A	B
TL50	18.25"	8.0"
TL75	28.25"	8.0"

Model	Model Description	Media Capacity	Overall Height	Flow Rate	Shipping Weight
45552504	SlimLine-50 Cart. Filter w/Base 1-1/2"	50	18.25"	30	8
45552754	SlimLine-75 Cart. Filter w/Base 1-1/2"	75	28.25"	50	11