

1920 MOUNTING HOLE LOCATIONS

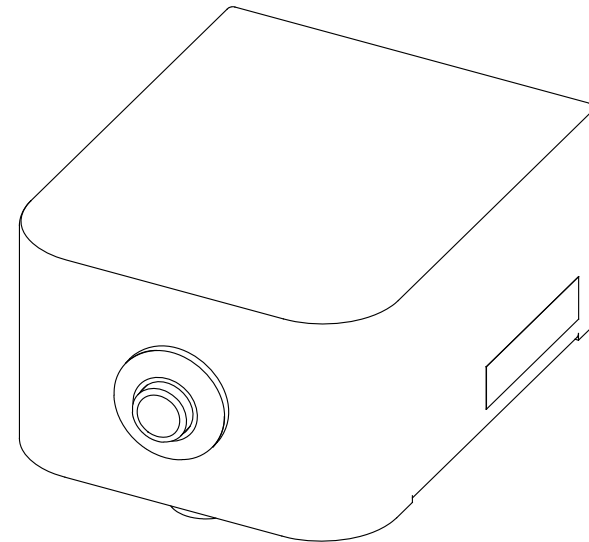
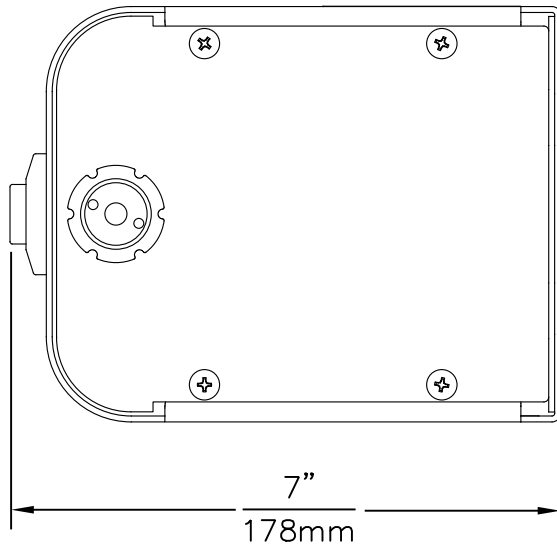

NOTES:

- 1 THIS BOTTLE FILLER REQUIRES THE USE OF MODEL 6521FR FREEZE RESISTANT VALVE ASSEMBLY (SOLD SEPERATELY)
- 2 VALVE ASSEMBLY MUST BE INSTALLED IN A WARM AREA. PROVISIONS SHOULD BE MADE TO ALLOW ACCESS TO THE ACCESS PANEL.
3. WHEN INSTALLING THIS UNIT, LOCAL, STATE OR FEDERAL CODES SHOULD BE ADHERED TO. FOR INSTALLATION HEIGHTS OTHER THAN SHOWN, DIMENSIONS MARKED (*) MUST BE ADJUSTED ACCORDINGLY.

		1455 KLEPPE LANE SPARKS, NEVADA 89431 (775) 359-4712 FAX (775) 359-7424 E-MAIL: HAWS@HAWS.CO.COM WEBSITE: WWW.HAWS.CO.COM	
		ECN NO. 5081 DRAWN: DS APPROVED: IR	REVISED PER: ECN: 5400 DATE: 05/25/16 DATE: 07/10/19
SCALE: N/A		DRAWING TYPE: INSTALLATION	SIZE: A SHEET 1 OF 3

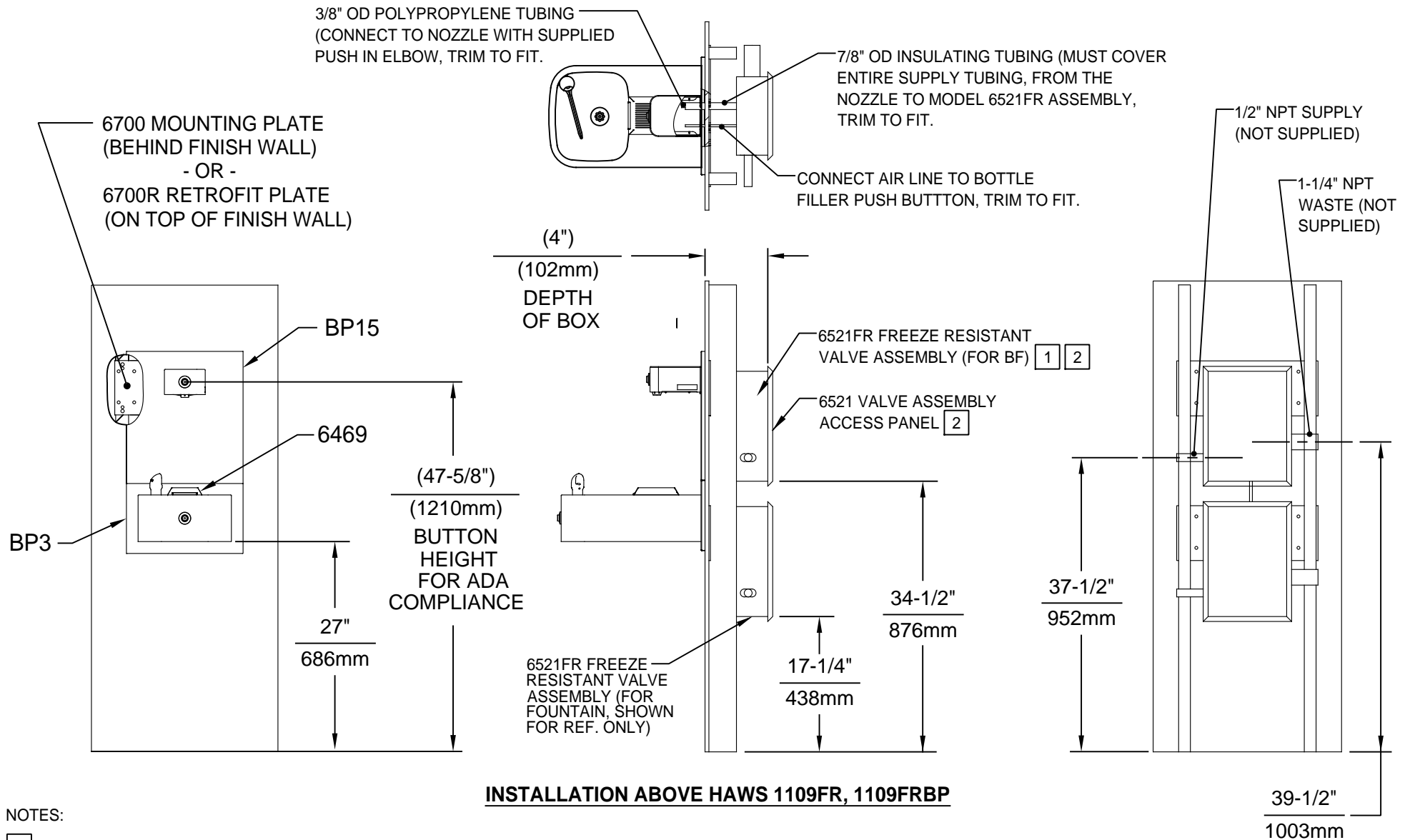

NOTES:

- 1 THIS BOTTLE FILLER REQUIRES THE USE OF MODEL 6521FR FREEZE RESISTANT VALVE ASSEMBLY (SOLD SEPERATELY)
- 2 VALVE ASSEMBLY MUST BE INSTALLED IN A WARM AREA. PROVISIONS SHOULD BE MADE TO ALLOW ACCESS TO THE ACCESS PANEL.
3. SEE SEPERATE INSTALLATION DRAWINGS FOR FOUNTAINS, MOUNTING PLATES, BACKPANELS, AND DRIP TRAY. HOLD ROUGH-IN DIMENSIONS ± 1/8" (3.2mm)
4. WHEN INSTALLING THIS UNIT, LOCAL, STATE OR FEDERAL CODES SHOULD BE ADHERED TO. FOR INSTALLATION HEIGHTS OTHER THAN SHOWN, DIMENSIONS MARKED (*) MUST BE ADJUSTED ACCORDINGLY.

		1455 KLEPPE LANE SPARKS, NEVADA 89431 (775) 359-4712 FAX (775) 359-7424 E-MAIL: HAWS@HAWS.CO.COM WEBSITE: WWW.HAWS.CO.COM	
		ECN NO. 5081 DRAWN: MJ APPROVED: IR	REVISED PER: FV DATE: 02/13/17 DATE: 07/10/19
SCALE: N/A		DRAWING TYPE: INSTALLATION	SIZE: A SHEET 2 OF 3

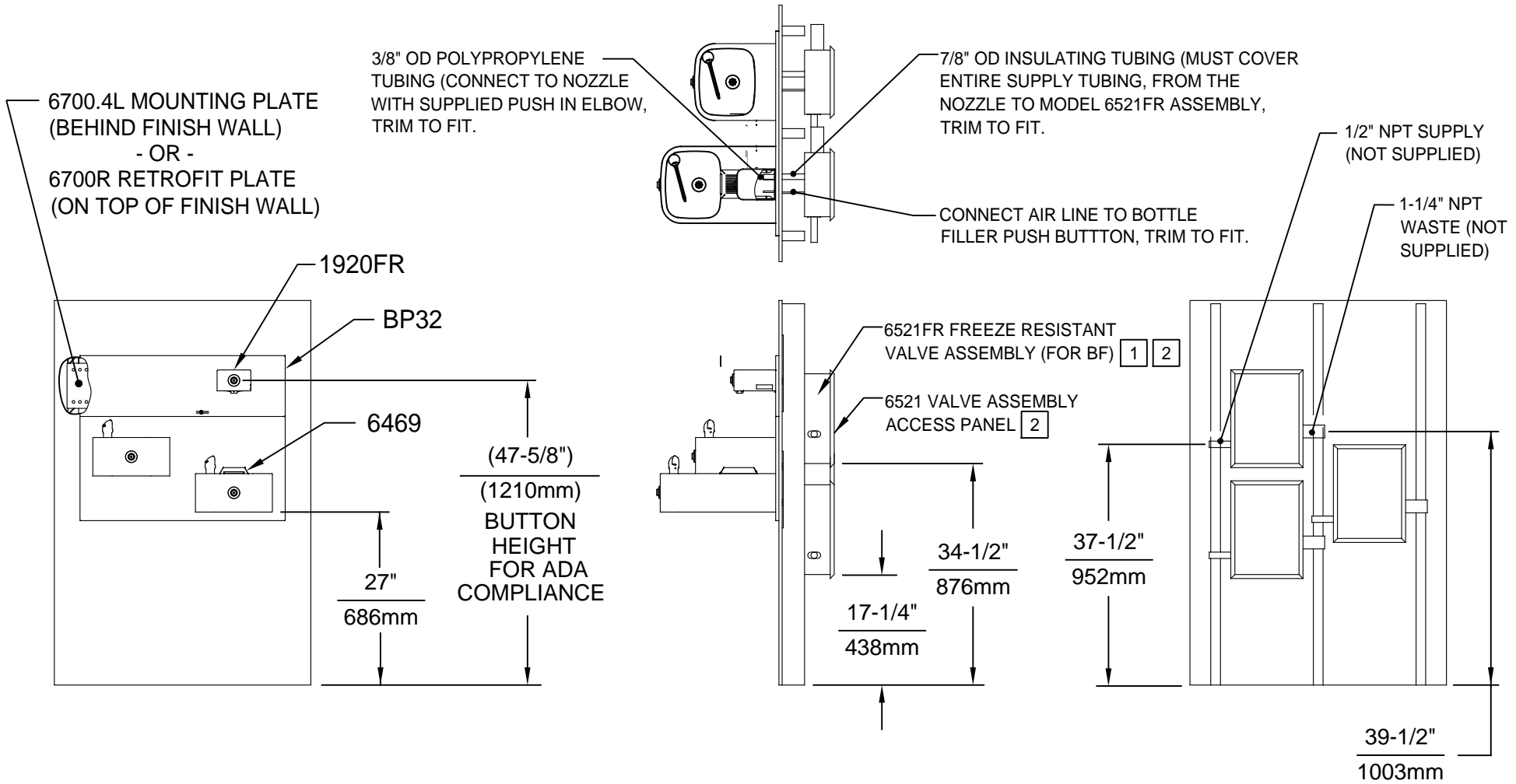

INSTALLATION ABOVE HAWS 1119FR

NOTES:

- 1 THIS BOTTLE FILLER REQUIRES THE USE OF MODEL 6521FR FREEZE RESISTANT VALVE ASSEMBLY (SOLD SEPERATELY)
- 2 VALVE ASSEMBLY MUST BE INSTALLED IN A WARM AREA. PROVISIONS SHOULD BE MADE TO ALLOW ACCESS TO THE ACCESS PANEL.
- 3. SEE SEPERATE INSTALLATION DRAWINGS FOR FOUNTAINS, MOUNTING PLATES, BACKPANELS, AND DRIP TRAY. HOLD ROUGH-IN DIMENSIONS ± 1/8" (3.2mm)
- 4. WHEN INSTALLING THIS UNIT, LOCAL, STATE OR FEDERAL CODES SHOULD BE ADHERED TO. FOR INSTALLATION HEIGHTS OTHER THAN SHOWN, DIMENSIONS MARKED (*) MUST BE ADJUSTED ACCORDINGLY.

		1455 KLEPPE LANE SPARKS, NEVADA 89431 (775) 359-4712 FAX (775) 359-7424 E-MAIL: HAWS@HAWS.CO.COM WEBSITE: WWW.HAWS.CO.COM	
		ECN NO. 5081 DRAWN: MJ APPROVED: IR	REVISED PER: FV DATE: 02/13/17 DATE: 07/10/19
SCALE: N/A		DRAWING TYPE: INSTALLATION	
SIZE: A		SHEET 3 OF 3	