

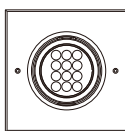

## XB2 LED Inground Light

### Overview

The XB2 commercial inground light has an adjustable beam direction. High efficiency light source. High quality aluminium lamp fixture. Beautiful appearance and reasonable waterproof structure. Tempered glass as cover. Heat resisting and impact resistance. Supplied with plastic installation container and 0.5 m of connecting cable.



EST-XB2BWSC



EST-XB2BWRC

EST-XB2BGRF

### Product Information

Product Code	Luminaire Power	Operating Power	Lumens	Light Distribution	Dimensions (w/ sleeve)	Lumens (w/o honeycomb)
EST-XB2BGRF-4K	6W	100V-240V	324	15°	D150 x H195mm	408
EST-XB2BWRC-3K	18.2W	100V-240V	1042	30°	D250 x H220mm	1389
EST-XB2BWSC-3K	18.2W	100V-240V	1042	30°	D250 x H220mm	1389

## Technical Specification

### Structure

Colours	Dark Grey
Material	Die-Cast Aluminium Housing with 316L Front Plate
Coating	Powder Coated
IP Rating	IP67
IK Rating	IK09 (6W) / IK10 (18.2W)
Glass Pressure Capacity	Full Area=783Kg (6W) / 5513Kg (18.2W)

### Performance

Light Source	OSRAM
Driver	100-240V, 50/60Hz
Colour Temperature	4000K (6W) / 3000K (18.2W)
Efficacy	54-76 Lm/W
Operating Current	30 mA (6W) / 82 mA (18.2W)
Warranty	2 Years in -20 to 40°C ambient

### Dimensions

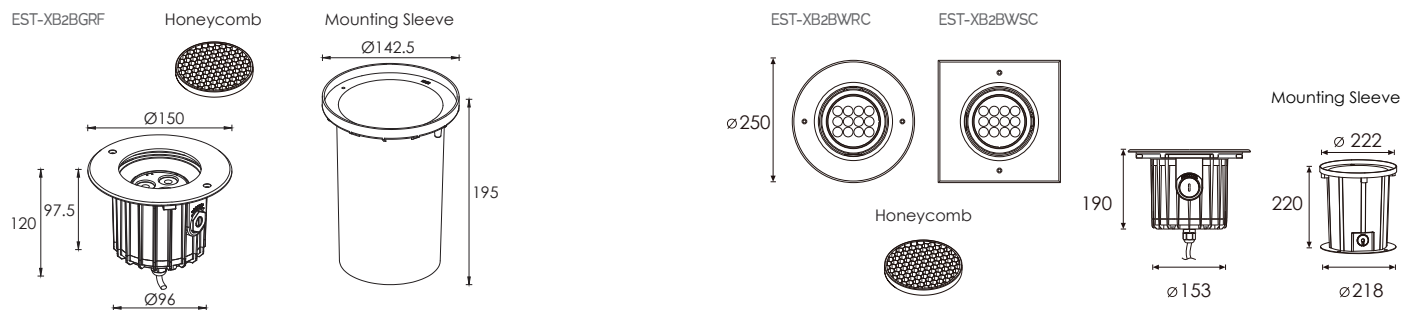

### Photometry

EST-XB2BGRF-4K

