

HEat. smART.

Partner in Baking. Since 1963



CANOVA

Mixer

45/60

USE AND MAINTENANCE

Translation of the original instructions



INTRODUCTION

We congratulate you for choosing a product designed and manufactured with cutting-edge technology.

In this manual you will find all the information on the Canova series mixers.

The product is checked and tested in the Manufacturer's plant before being delivered to the customer.

The "production process check sheet" enclosed with it guarantees that **each** step in the production process, from assembly to packaging, was carefully checked from both the operating and safety standpoints.

Before the use, read the content of this manual **carefully**: it contains important information regarding product assembly and safety regulations.

TECHNICAL SERVICE

Your Dealer can solve any technical problem regarding use and maintenance.

Do not hesitate to contact him in case of doubt.

CUPPONE since 1963

CUPPONE S.R.L.

Via Sile, 36

31057 Silea (TV) - ITALY

T +39 0422 361143

F +39 0422 360993

info@cuppone.com - www.cuppone.com

THE FOUNDATION

Our company was founded in 1963 by the Lorenzo, Luigi and Paolo Cuppone brothers. It immediately specialized in the production of ovens and equipment to prepare and cook pizza.

The constant research and experimentation of new equipment that are even now the strength of our company, have led us to design and patent the machinery and ovens that have revolutionized the way pizza is made.

CONTENTS

1	SAFETY INSTRUCTIONS.....	3
----------	---------------------------------	----------

2	BASIC NOTIONS.....	6
	USE.....	7
	Powering the appliance	7
3	Turning the ON/OFF switch	7
	Inserting the ingredients.....	8
	Processing	9
	Unlocking the emergency mushroom	10

	MAINTENANCE.....	11
	Cleaning the appliance.....	11
	Cleaning the external steel parts	11
	Cleaning the bowl, spiral and dough-breaking rod	11
4	Cleaning the control panel	11
	Downtime for prolonged periods.....	11
	Maintenance and cleaning	11
	Disposing of food residues.....	12
	Equipment disposal	12

5	SOMETHING IS NOT WORKING... ..	13
----------	---------------------------------------	-----------

6	WARRANTY	14
----------	-----------------------	-----------

TRANSLATION OF ORIGINAL INSTRUCTIONS

The original language used to prepare this manual is Italian: the Manufacturer is not responsible for any translation/interpretation or print errors.

1 SAFETY INSTRUCTIONS

SYMBOLS USED IN THE MANUAL AND ON THE LABELS APPLIED TO THE MACHINE

 Indicates that caution is required when performing an operation described in a paragraph that bears this symbol. The symbol also indicates that maximum operator awareness is required in order to avoid unwanted or dangerous consequences

 Dangerous voltage

 Risk of explosion

 Hand crushing hazard

 Do not remove the guard

 No spraying with water

 No smoking

 Reference to another chapter where the subject is dealt with in more detail.

 Manufacturer's tip

 Manufacturer's warning

 Indicates that it is necessary to read carefully the paragraph marked with this symbol before installing, using and maintaining the equipment

GENERAL WARNINGS

- Read this guide carefully before using and maintaining the appliance, and keep it with care in an accessible place for any future consultation by the various operators. The manual must always accompany the product throughout its life, even in case of transfer (pursuant to current regulations, the instruction manual is an integral part of the machine). In the event of loss or deterioration, request further copies of the manual from the Manufacturer.
- Non-compliance with the following rules can cause damage and even fatal injuries, invalidates the warranty and releases the Manufacturer from all liability.
- Use or maintenance other than those indicated in this booklet or interventions, tampering or modifications not expressly authorized can cause damage, injury or fatal accidents and void the warranty.
- This booklet is dedicated to machine operators, i.e. people in charge/authorized to use a machine. Employers, executives and supervisors, in addition to reading and understanding this manual, must ensure the same reading and understanding by any of the aforementioned operators.
- In case of fire, use dry fire extinguishers to prevent it from flaring up.

- The serial plate provides important technical information. This is vital in case of a request for maintenance or repair of the equipment: please do not remove, damage or modify it.
- Monitor the equipment throughout its operation.
- The airborne noise produced by the machine is < 70dBa at the operator position (measurement carried out with a Class 1 integrating sound level meter).
- Do not disassemble, modify or disable machine parts (functional parts, control systems and safety devices).

DESTINATION AND DESIGNATION OF USE

- The equipment is a spiral mixer, designed to mix doughs for pizzerias, bakeries or pastry shops.
- These appliances are intended to be used for commercial applications, for example in restaurant kitchens, canteens, hospitals and commercial companies such as bakeries, butcher shops, etc., but not for the continuous and mass production of food. A use other than the stated one is considered improper, potentially dangerous for people and animals and might permanently damage the appliance.

Safety instructions

- This appliance can be used by children aged from 8 years and above and persons with reduced physical, sensory or mental capabilities or lack of experience and knowledge if they have been given supervision or instruction concerning the use of the appliance in a safe way and understand the hazard involved.
- The staff using the appliance must be professionally prepared and periodically trained on its use, as well as the safety and accident prevention regulations. It must also wear the PPE (personal protective equipment) required by the internal regulations of the factory and be in perfect psycho-physical shape. It is absolutely forbidden for an external or unauthorized person to approach the machine when it is in operation.
- During the exercise of their duties, workers must not use personal clothing and clothing which, based on the nature of the operations or the characteristics of the work, constitute a danger to personal safety (e.g. bracelets, chains or other objects that can get caught in the moving parts).
- Children must be supervised to make sure they do not play with the appliance or parts of it.
- Only one operator at a time can work on the machine.

MAINTENANCE WARNINGS

- Before carrying out any maintenance operation, disconnect the appliance from the power supply and wait for the discharge times (about 2-3 minutes).
- Do not wash the machine with detergents other than those indicated in this handbook in the dedicated chapter or with jets of water or steam.
- Cleaning and user maintenance shall not be made by children without supervision.

POSSIBLE RESIDUAL HAZARDS/ RISKS

- FIRE RISK: leave the area around the appliance free and clean from fuels. Do not store flammable materials near this appliance.
- WARNING: RISK OF EXPLOSION! It is forbidden to use the product in environments at risk of explosion.
- WARNING: always switch off the main switch when you finish using the appliance, above all during cleaning or in cases of prolonged downtime.

WARNINGS IN CASE OF FAILURE

- If you notice any anomaly (e.g. damaged power cable, etc.), malfunction or fault, do not use the appliance and contact a Service Centre authorized by the Retailer. Demand original spare parts, or the Warranty will be null and void.
- To avoid risks, if the power cable is damaged, it must be replaced by a Service Centre, the Retailer, its service agent or qualified personnel.
- The operator is obliged to immediately report any damage or modifications to the machine which may compromise its safety. In the event of a breakdown, disconnect the machine from the power supply, notify all the operators involved and signal with signs understandable by all the operators involved that the machine is not usable.
- Place the emergency phone numbers in a visible location.
- We recommend you have the appliance checked by an Authorized Service Centre at least once a year.

Safety instructions

INCORRECT USE

- Since the machine was designed and built to ensure safety only in the event of intended use, keep the following requirements in mind. It is forbidden to use the appliance:
 - in a way other than that it was designed and built for; improper use voids the warranty and exposes you to potential dangers;
 - in areas with lighting < 150 lux, at risk of explosion, with excess water or oil vapour or dust;
 - in the presence of corrosive substances and/or gases;
 - with environmental conditions other than those specified in the installation manual;
 - for the processing of materials and/or for products other than food, notoriously used in the bakery and pastry sector;
 - under conditions of abnormal vibration or shock. In combination with other equipment, machines, etc.

The company cannot be held liable for any print or transcription errors, reserving the right to make changes where deemed suitable without prior notice.

Partial reproduction without the Manufacturer's consent is prohibited. Measurements are purely indicative and not binding.

SYMBOLS APPLIED TO THE MACHINE

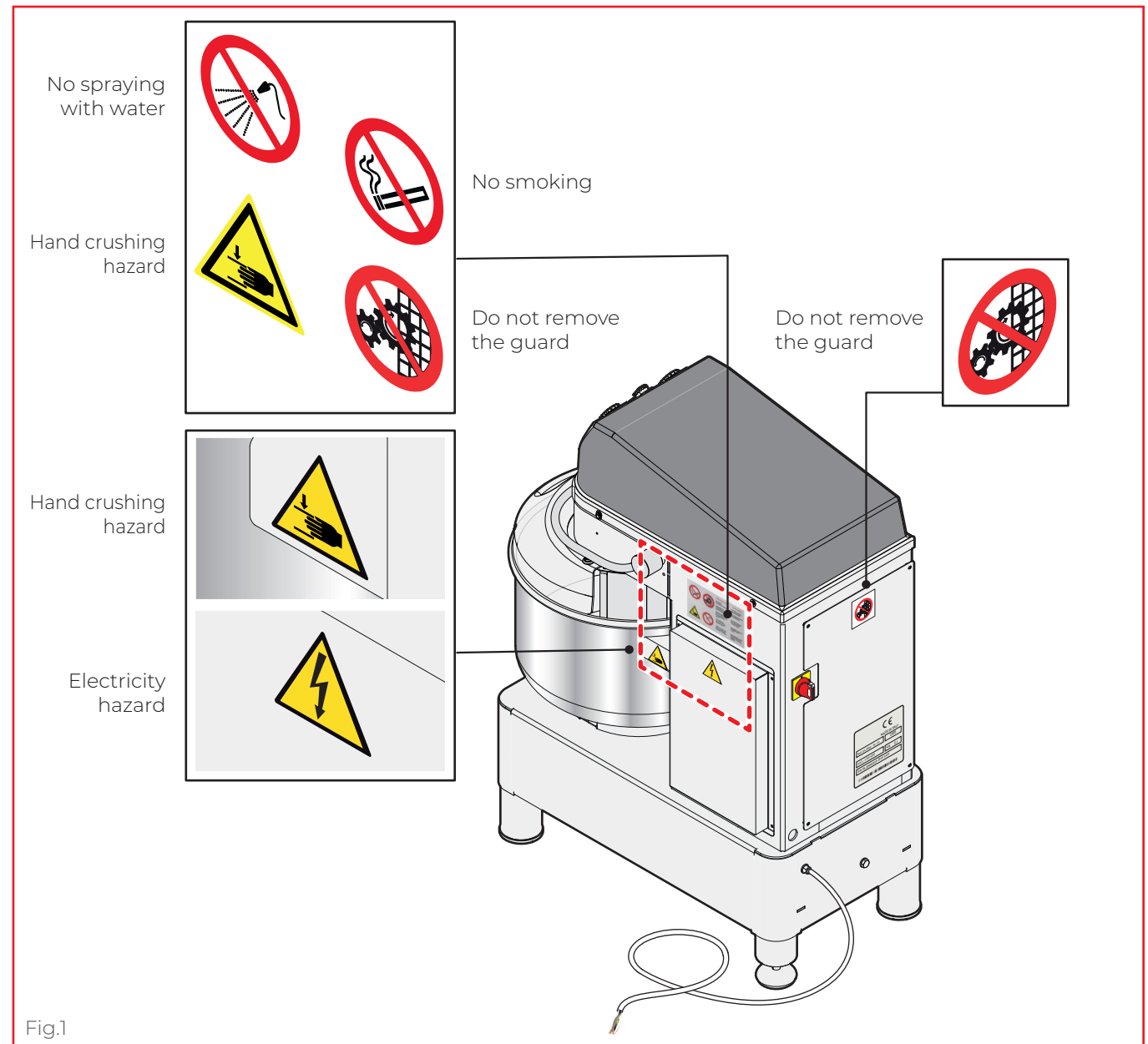

2 BASIC NOTIONS

MACHINE DESCRIPTION

The appliance is a **spiral mixer**, designed for the production of doughs with food-grade ingredients which are subsequently used for confectionery or bread-making products. Conceived to obtain the best in terms of soft doughs, where the yeasts, both natural (sourdough) and traditional, can work in the most suitable environment possible to develop their potential.

► **Fig.2** The main parts of the machine are:

- 1 **Base** in varnished steel
- 2 **Stabilising feet**
- 3 AISI 304 stainless steel **rotating mixing bowl**
- 4 AISI 431 stainless steel **spiral tool**
- 5 AISI 304 stainless steel contrast **column**
- 6 AISI 304 stainless **flour guard**
- 7 **PETG accident protection guard**: prevents you from inserting your hands into the bowl during processing
- 8 Bowl **thrust rollers**
- 9 **Control panel**
- 10 **ON/OFF switch**
- 11 **Arrow**: shows the correct direction of rotation of the bowl
- 12 **Power cable**

Fig.2

airborne noise produced by the appliance < 70dBa at the operator position

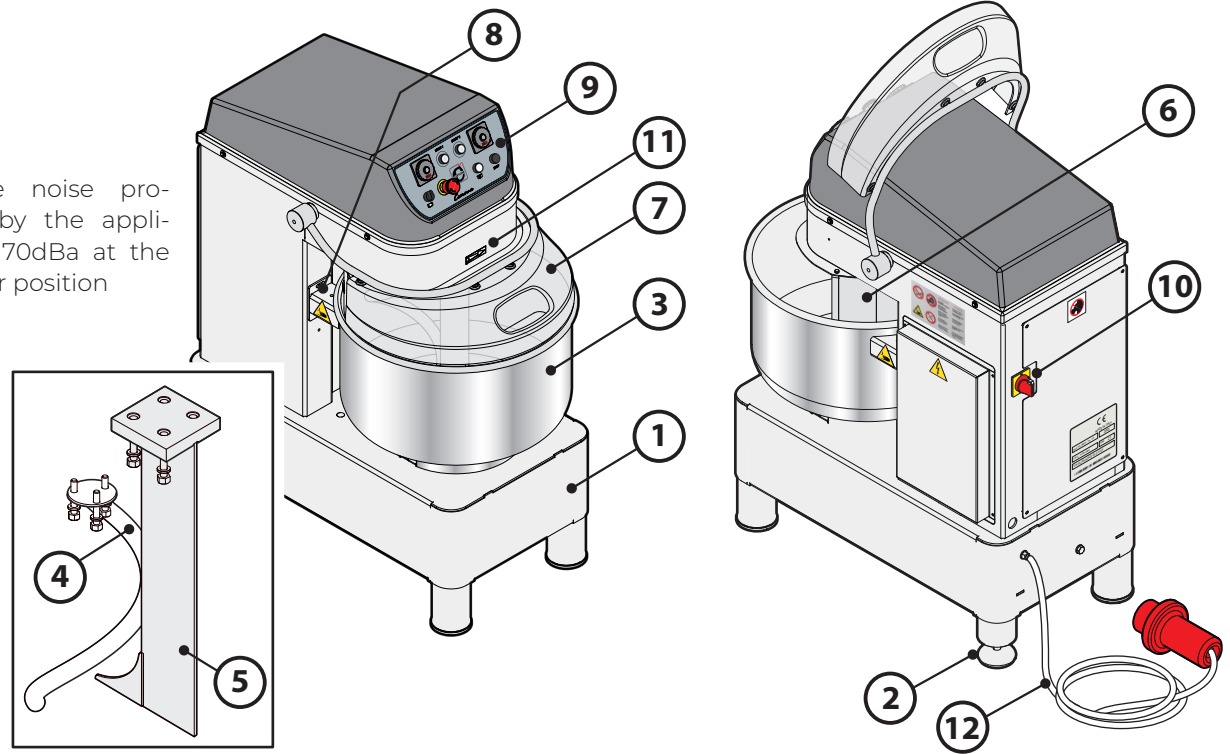

► **Fig.3** Control panel

- 1 **Timer** operation in speed 1
- 2 **Start button** of the appliance with speed 1
- 3 **Timer** operation in speed 2
- 4 **Start button** of the appliance with speed 2
- 5 **Stop button**
- 6 Bowl **rotation button** also with bowl cover lifted
- 7 **Inversion button** of the bowl direction of rotation
- 8 **Emergency mushroom**: if pressed, it stops the operation. To unlock it and restart normal operation, rotate it in a clockwise direction. The mushroom must be used in a real emergency; to stop the appliance normally, use the STOP button.
- 9 **Display** of speed 1 time
- 10 **Display** of speed 2 time

Fig.3

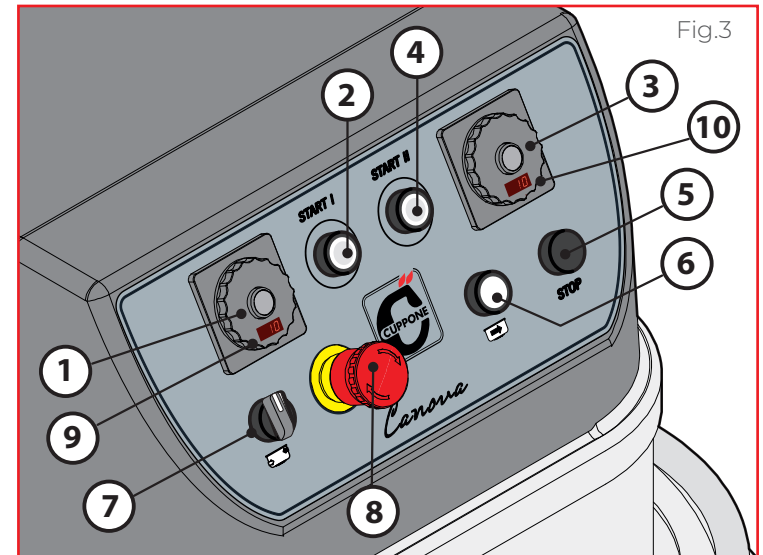

3 USE

The use of the machine is reserved to suitably trained and qualified operators

Only one operator at a time can work on the machine.

Before starting the appliance:

- check that all safety devices (emergency mushroom **Ⓚ** ► Fig.3) are working perfectly; its functionality is checked by pressing it and making sure that the appliance immediately stops working. In the event of anomalies or inefficiencies, immediately notify the manager in charge;
- **⚠** carefully read what is described and prescribed in the previous pages of this document (in particular the “SAFETY” chapter);
- learn the position and function of all the control, indication and safety devices present.

POWERING THE APPLIANCE

► Fig.4

Insert the appliance plug into the socket provided to power it.

After connection, make sure that the cable:

- is not hindering the passage of people or objects (e.g. trolleys on wheels);
- is not crushed or bent;
- is not placed near sharp edges or hot surfaces.

Extending the cable or using extension cables is not permitted.

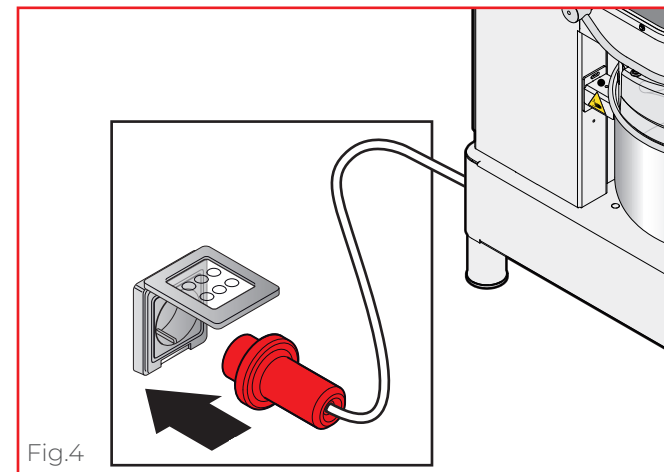

Fig.4

TURNING THE APPLIANCE ON

► Fig.6 Position the ON-OFF switch located on the back in the ON - I position.

To turn off the equipment at the end of processing, position the switch on OFF - O.

⚠ During maintenance or cleaning operations, it is not enough to operate this switch alone, but it is mandatory to remove the appliance plug from the socket.

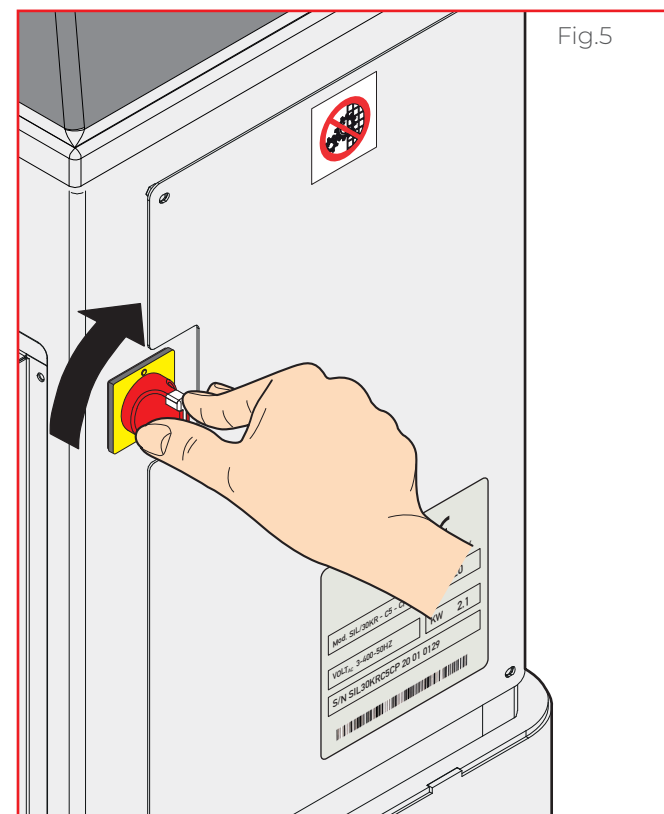



Fig.5

INSERT THE INGREDIENTS

► **Fig.6** The machine mixes the dough thanks to the rotating movement of the bowl and the steel spiral tool. When using for the first time, clean by carefully following the instructions in the dedicated chapter.

 Maintenance and cleaning - page 12.

A Lift the safety guard in PETG;

B manually insert the ingredients into the bowl complying with the order and the quantities stated in the recipe.

 **It is advisable to load the flour first and then the water;** in this way the flour, getting wet, increases its specific weight but the volume remains unchanged; any additions of ingredients during processing can take place through the special opening on the bowl cover.

C lower the protective cover again; if it is lifted during kneading, the movement of the spiral tool and the bowl is interrupted.

 **Limit the dispersion of the ingredients in the environment and in the other components of the machine for hygienic and safety reasons (e.g. flour dust).**

 **An infiltration of residues into the mechanical parts can cause the machine to malfunction.**

 **The ingredients must be mixed in such a way that the sum of their masses does not exceed the capacity of the machine (CANOVA 45: 45 kg [99.2 lbs] CANOVA 60: 60 kg [132 lbs]).**

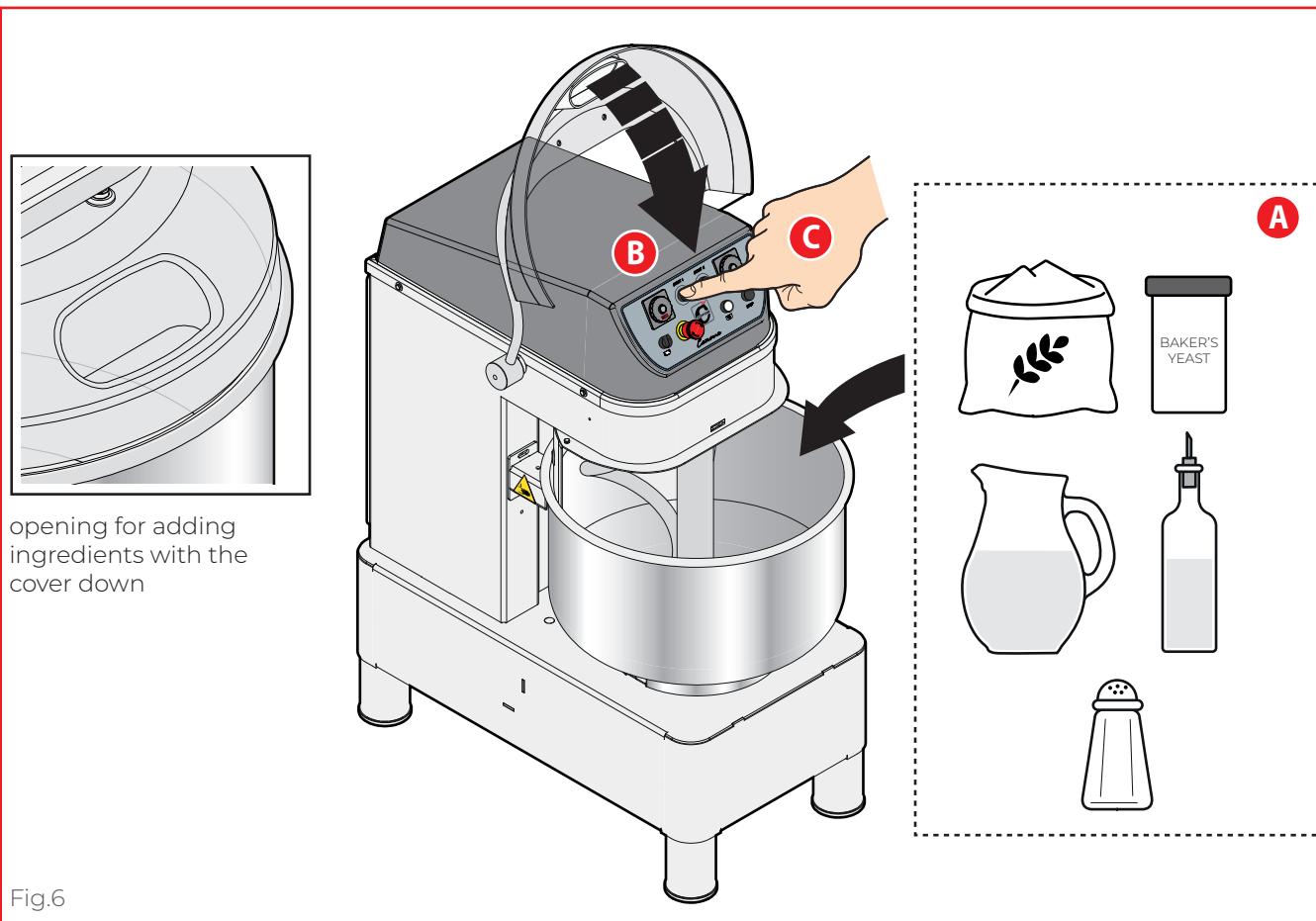

Do not try to recover the flour that settles on the parts of the machine; this could lead to food contamination with a consequent risk to the health of consumers, and also a risk to the operator's safety should he try to introduce hands, fingers, etc. in spaces characterized by the presence of moving parts (for example between the bowl edge and the guard, between the bowl wall and the base column, etc.).

Failure to comply with the hygiene rules can cause modifications to the food product and constitute a health risk with possible physical, chemical and microbial contamination.

After powering up the machine, check the direction of rotation of the bowl and of the spiral tool, which must be anticlockwise as indicated by the arrow on the head of the appliance.

PROCESSING

► Fig.7 Processing can start in one of the following ways:

If...	the appliance...	processing stops...
... the START I button is pressed (2)	... will start in low speed	... when the STOP button is pressed (5)
... the START II button is pressed (4)	... will start in high speed	
... the timer (1) is rotated until the display shows the desired rotation time and then the START I button is pressed (2)	... low speed starts and the countdown on the display starts (9)	... automatically at the end of the set time (visible on the display (9) or (10) according to the chosen speed)
... the timer (3) is rotated until it shows the desired rotation time and then the START II button is pressed (4)	... high speed starts and the countdown on the display starts (10)	



If both timers (1) and (3) are set, when the **START I** (2) button is pressed, the appliance will mix at speed 1 for the time set by the timer (1), then, without any operator's intervention, it will start to mix again in speed 2 for the time set by the timer (3).

Caution! To contain the development of dust within the terms established by the hygiene standards, the appliance must be started at speed 1 and after at least 120 seconds switch to speed 2.

► Fig.8 Rotating the **lever** (7), it is possible to check the bowl rotation:

Knob position	Effect on the bowl
	the bowl DOES NOT rotate (only the spiral tool rotates (4) ► Fig.2)
	the bowl rotates in a CLOCKWISE direction (normal operation shown by the arrow (11) ► Fig.2)
	the bowl rotates in an ANTICLOCKWISE direction

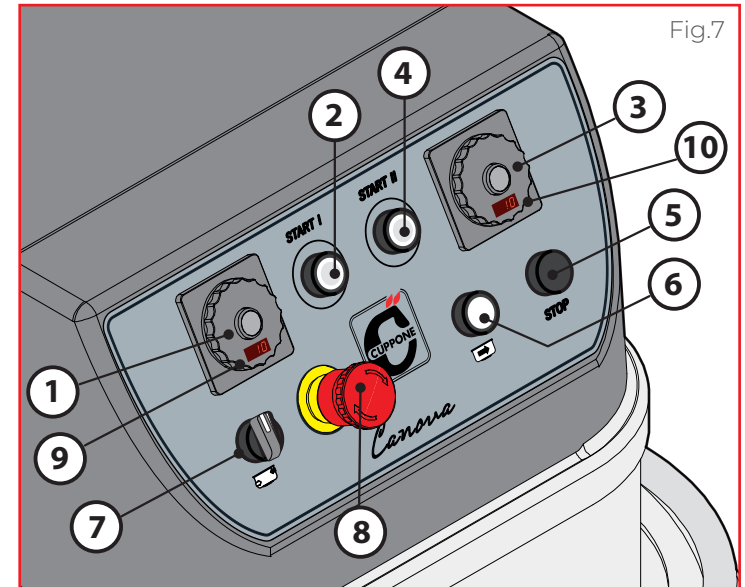

Fig.7

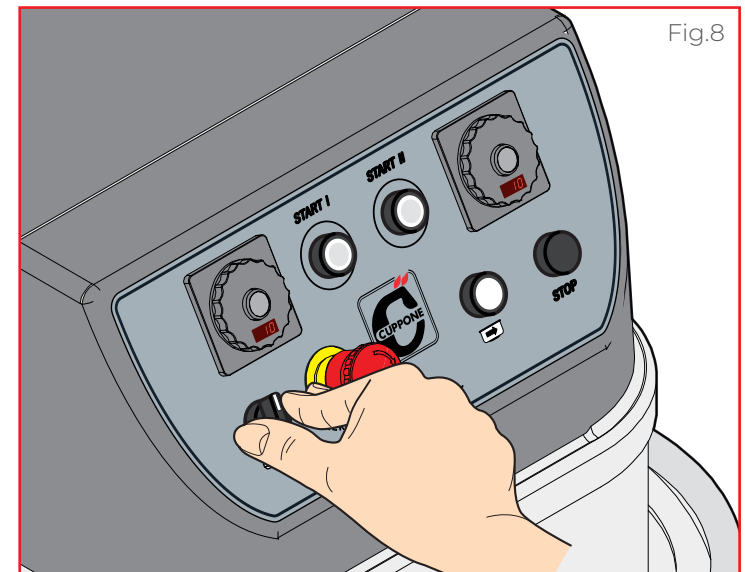

Fig.8

REMOVING THE DOUGH

At the end of the desired time, stop the machine by pressing the STOP button (it is not necessary if a timer has been used, the machine stops automatically) and lift the guard to remove the dough; for safety reasons, the movement of the spiral tool and the bowl is interrupted anyway.

► **Fig.9** By pressing the **key 6** it is possible to rotate the bowl even with the guard raised (the spiral tool remains stationary); this facilitates the operations of removing the dough.

Take the dough, dividing it into small portions, the size and mass of which are such that they can be handled easily and without risk.

Use a plastic spatula to remove any dough residues (never use metal spatulas or scrapers).

UNLOCKING THE EMERGENCY MUSHROOM

► **Fig.10**

If pressed, the emergency button interrupts the appliance operation. To unlock it and restart the normal working activity, rotate it clockwise. The mushroom must be used in a real emergency; to stop the appliance normally, use the STOP button. **5** ► **Fig.2**.

! **Warning: when the appliance is stopped voluntarily by lifting the guard or by pressing the emergency button with the mixer in motion, it will restart from the point where the work cycle was interrupted.**

! **Periodically check the functionality of the emergency mushroom by pressing it and making sure that the appliance stops working immediately.**

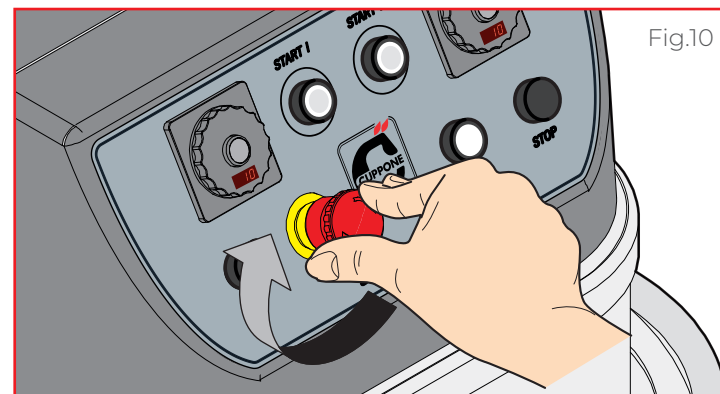
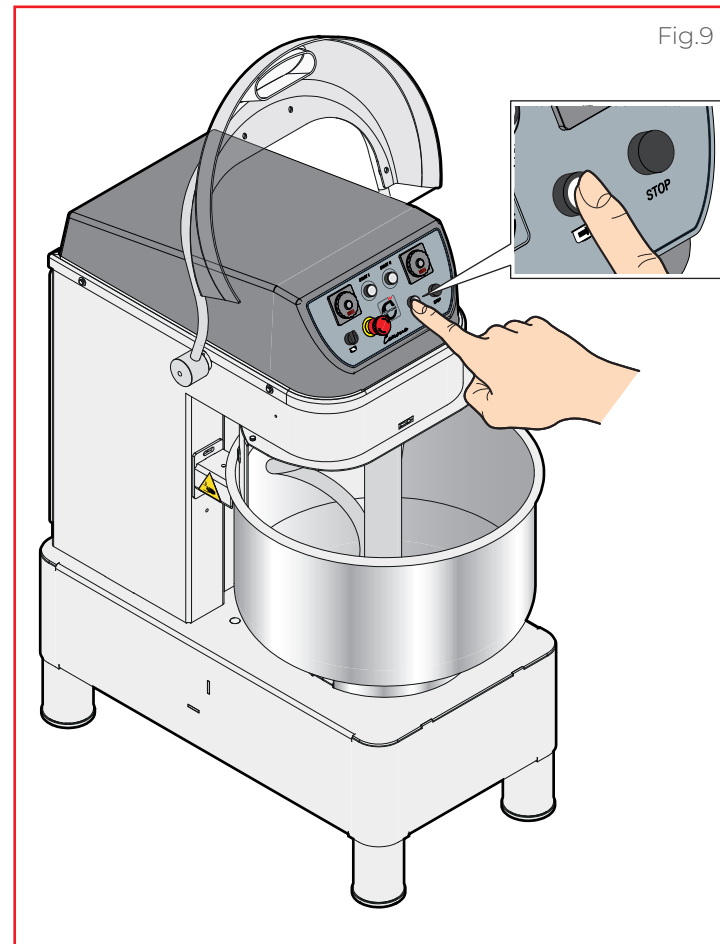

4 MAINTENANCE AND CLEANING

WARNINGS

 Before carrying out any cleaning operation, it is necessary to **disconnect the electrical power supply** to the appliance (by acting on the system switch) and to wear suitable personal protective equipment (gloves, waterproof goggles, dust mask, shoes with reinforced toes). The user must carry out only routine maintenance (cleaning), for extraordinary maintenance, contact the Dealer requesting service from an authorised technician. The Manufacturer warranty does not cover damages due to negligent or incorrect maintenance or cleaning (e.g. use of unsuitable detergents).

 **The cleaning of any component must be carried out with the machine completely cold and wearing personal protective equipment.**

When cleaning any part or accessory do NOT use:

- abrasive or powder detergents;
- aggressive or corrosive detergents (e.g. hydrochloric/muriatic or sulphuric acid, caustic soda, etc.), not even to wash the floor underneath the appliance;
- abrasive or sharp tools (e.g. abrasive sponges, scrapers, steel brushes, etc.);
- steamed or pressurised water jets.

 It is best to have a service centre perform maintenance and inspection on the appliance at least once a year to ensure top working and safety conditions.

CLEANING THE APPLIANCE

The machine must be kept in perfect hygienic conditions. Below is a table with the cleaning frequency of each component of the appliance.

Failure to comply with the hygiene rules can cause modifications to the food product and constitute a health risk with possible physical, chemical and microbial contamination.

 **Before carrying out any cleaning, make sure that the power supply has been switched off.**

Component	Cleaning frequency	Cleaning method
<ul style="list-style-type: none"> ■ spiral tool ■ contrast column ■ mixing bowl ■ flour guard 	daily , at the end of each working day	Use a cloth soaked in warm soapy water or a detergent suitable for cleaning surfaces in contact with food. Finish with thorough rinsing and drying, taking care to remove all traces of detergent.
external steel parts	as required	Use a cloth soaked in hot soapy water and finish with a thorough rinsing and drying, taking care to remove all traces of detergent.
overall cleaning (residues and scaling)	once a month	Use a vacuum cleaner.
control panel	as required	Clean the control panel with a soft cloth and a little detergent for delicate surfaces. Avoid using considerable quantities of product since any infiltration may damage the keys. Avoid also using very aggressive detergents that may damage the polycarbonate screen printing.
inner part of the safety guard in PETG	weekly or as required	Use a soft cloth soaked in a detergent suitable for cleaning delicate surfaces in contact with food, in order not to damage the PETG coating. Finish with thorough rinsing and drying, taking care to remove all traces of detergent and not to damage the PETG coating.

Maintenance and cleaning

DOWNTIME FOR PROLONGED PERIODS

During periods of inactivity, disconnect the power supply and cover the machine with a waterproof sheet to protect it from dust, insects, rodents, etc. Protect the external steel parts of the appliance by wiping them with a soft cloth lightly soaked in Vaseline oil.

Before resuming operations:

- carefully clean the appliance and accessories
- ▶ Fig.11;
- reconnect the equipment to the power;
- inspect the equipment before using it.

DISPOSING OF FOOD RESIDUES

! The food residues removed when cleaning must be disposed of in compliance with the regulations in force in the country where the product is used.

If in doubt, we suggest contacting the local authorities to ask for the correct method of disposal.

DISPOSAL AT END OF LIFE

! To avoid any unauthorised use and associated risks, before discarding the machine make sure it cannot be used; for this purpose, cut and remove the power cord (once the equipment is unplugged).



Pursuant to art. 13 of Legislative Decree no. 49 of 2014 "Implementation of WEEE directive 2012/19/EU on electric and electronic waste", the barred bin symbol specifies that the product was introduced on the market after August 13, 2005 and that it must not be discarded with other waste at the end of its working life but disposed of separately. All the equipment has been made with recyclable metal materials (stainless steel, iron, aluminium, zinc plate, copper, etc.) that as a percentage make up more than 90% of the weight. Attention must be paid to the management of this product at the end of its life, reducing any negative impact on the environment and improving the efficiency of resources, applying the principles of "who pollutes pays", prevention, preparation for re-use, recycling and recovery. Please remember that illicit or incorrect product disposal is punishable by law.

Information on disposal in Italy

WEEE equipment in Italy must be delivered to:

- to Collection Centres (also named eco-islands or eco-platforms);
- the dealer where new equipment is purchased who must withdraw it free of charge ("one to one" withdrawal).

Information on disposal in European Union countries

The EU Directives on WEEE equipment has been adopted in different ways by different countries, therefore in order to dispose of this equipment correctly we suggest that you contact your local authority or your dealer in order to ask the correct method of disposal.

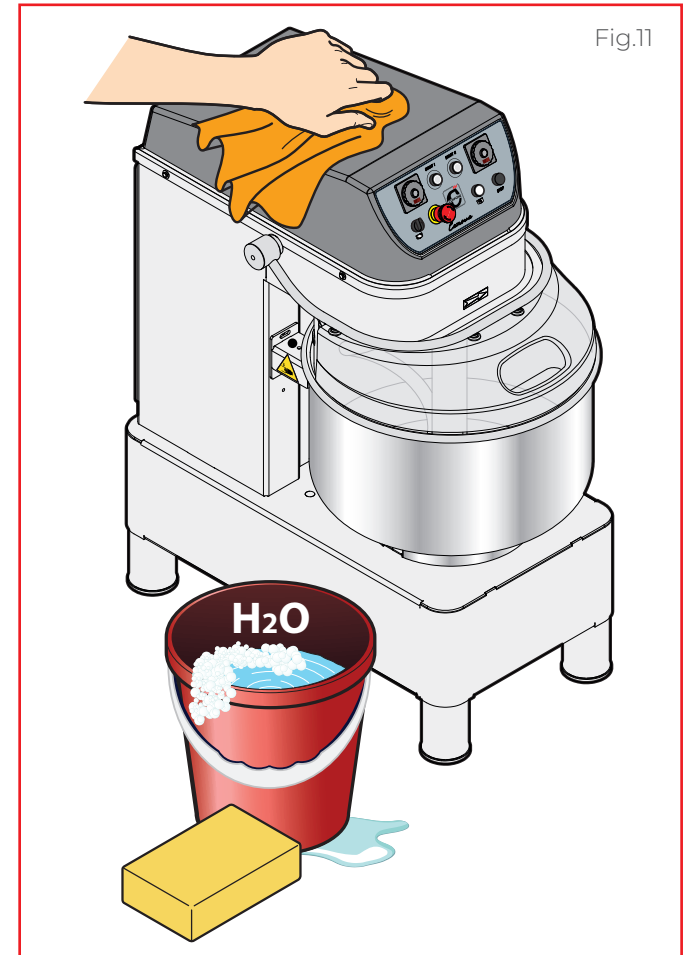

Fig.11

5 SOMETHING IS NOT WORKING...

WHAT TO DO IN CASE OF ANY MALFUNCTION

- Note the product data (rating plate) and the date and number of the appliance purchase invoice.

Serial number.....

Model.....

Invoice date.....

Invoice number.....

- Read the chapter on warranty carefully.



Warranty - page 14.

- Call an authorised Service Centre or call the dealer directly stating the appliance data. While waiting for Technical service, disconnect the appliance from the mains.

Fig.12

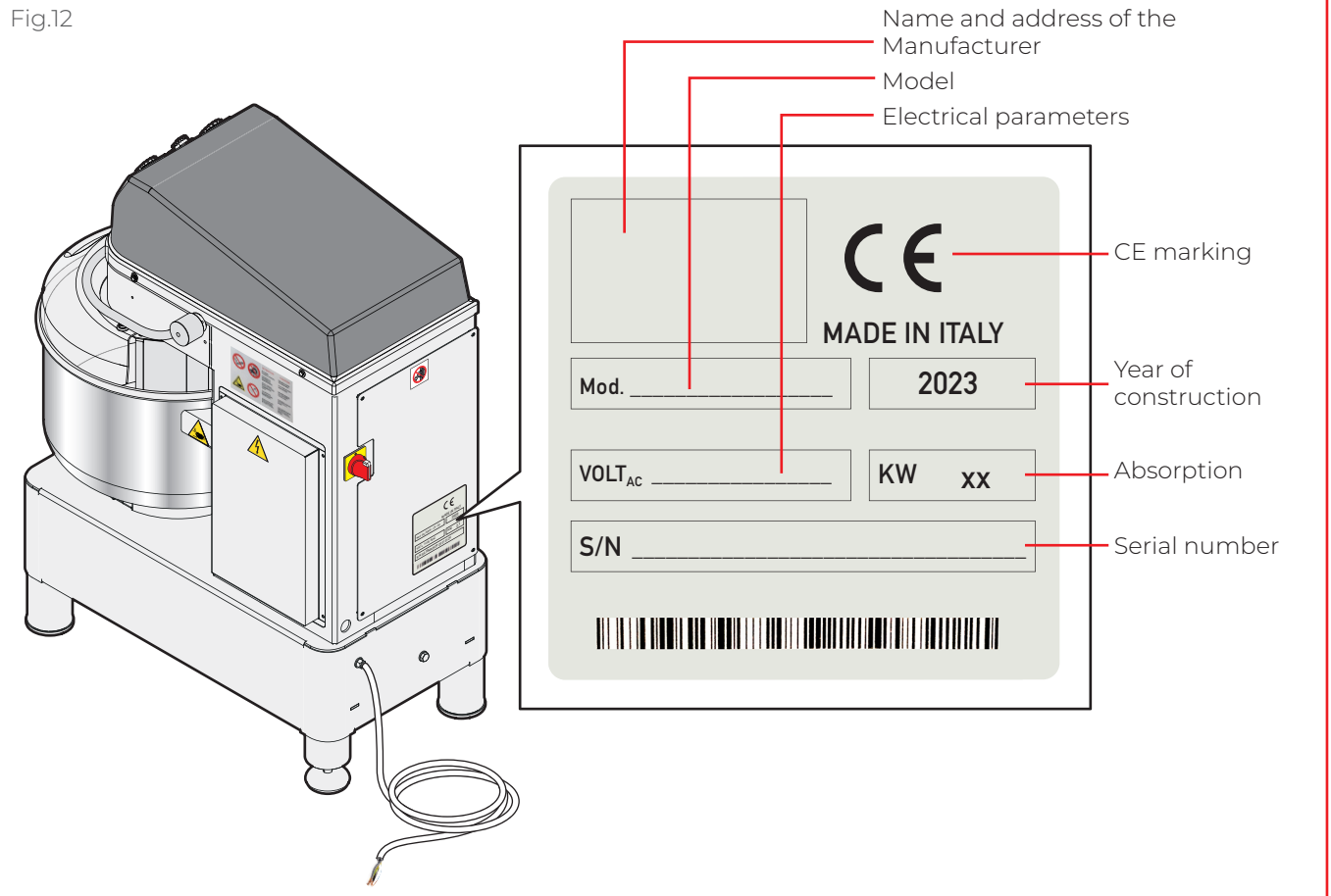

ONCE THE APPLIANCE HAS BEEN INSTALLED, THE DEALER MUST ACTIVATE THE WARRANTY.

CUPPONE since 1963
CUPPONE S.R.L.
Via Sile, 36
31057 Silea (TV) - ITALY
T +39 0422 361143
F +39 0422 360993
info@cuppone.com - www.cuppone.com

6 WARRANTY

- 8.1 Each product sold is to be considered compliant when delivered in the quantity, quality and type indicated in the written Confirmation, please refer to the provisions of art. 1.2.
- 8.2 The Seller guarantees:
 - (a) that the Products are free from defects in materials or workmanship, and
 - (b) that (excluding the case of known defects or which should have been known by the Buyer) the Products are of marketable quality.
- 8.3 Any hidden defects in the Products must be reported in writing by the Buyer within 8 days of discovery, under penalty of forfeiture. Packaging defects - even if they have caused defects or damage to the internal product - which had to be reported at the time of delivery, are excluded pursuant to art. 5.8.
- The defect report must contain the specific indication of the defective Products, a detailed description of the type of defect that the Product has, as well as the delivery date and that of discovery.
- The warranty is excluded if the defect derives from the Purchaser's actions such as, by way of example, incorrect installation of the Product, use of the Product in a manner that does not comply with the normal method of use, failure to comply with the instructions contained in the use and installation manual, tampering with the Product. The warranty does not cover normal wear and tear of the Product due to use.
- The Seller is responsible for defects that occur within one year from the activation of the warranty as provided for in point 8.12.
- 8.4 the Seller will have the right to examine, or have a representative examine, the Product and, if this shows the existence of the defect, the Buyer will be entitled to a repair or replacement, at the Seller's sole discretion.
- It is understood that, once the defect has been reported, the Buyer must not use the Product until it is viewed by the Seller or its representative. In the event that the Seller realizes that the Product has been used after the complaint, the Buyer loses the right to obtain a replacement or repair.
- 8.5 Replacement or repair will take place under the following terms:
 - a) The Seller may repair the defective Products by going - or sending a representative - to the place where such Products are located;
 - b) Alternatively, the Seller may repair the defective Product at its own factory, or other place chosen by the Seller,
 - c) Alternatively, the Seller may opt for the replacement of the defective Products;
- In the event that the repair / replacement is not possible, the Seller will pay the Buyer a refund to be quantified, a refund which, however, must not exceed the price paid. Compensation for damage is excluded.
- 8.6. In case of repair of the Product at a place chosen by the Seller or in case of replacement of the defective Product, the shipment of the Product will be borne by the Buyer who must send it, at its own expense and risk, to the place stated by the Seller.
- 8.7 In no case will the Seller be liable for indirect or consequential damages and/or for loss of profits that the Buyer may suffer as a result of defects in the products such as (but not limited to) cancellation of orders by customers, penalties for delayed deliveries, penalties or refunds of any kind.
- 8.8 The Seller shall indemnify the Buyer from any liability or damage arising from defective Products, unless such liability derives from the Buyer's negligent acts or omissions or from the latter's non-fulfilment of its obligations.
- 8.9 The Seller is not liable for damage to persons and/or property that may derive from the improper use of the Products and/or from any use, processing or transformation of the Products that do not comply with their intended use and/or the instructions provided by the Seller. Save the hypothesis of gross negligence or wilful misconduct by the Seller.
- The Seller will also not be liable in the event of damage to property or injury to people or in the case of malfunction or damage or deterioration of the Product deriving from the fact that the Product has been connected to a non-compliant electrical system.
- 8.10 The Buyer will not be able to raise any claim for injury to people or damage to property other than those which are the subject of the contract, or for loss of profit, unless it results from the circumstances of the case that the Seller has committed "gross negligence".
- 8.11 "Gross negligence" does not include any and all lack of adequate care and expertise, but means an act or omission by the Seller which implies either a failure to take into consideration those serious consequences that a conscientious supplier would normally have foreseen as probably occurring, or a deliberate neglect of any consequence deriving from such act or omission.
- 8.12 The effect of the warranty referred to in this article is subject to its activation to be carried out through the website www.cuppone.com within 48 hours after the time the Product is installed.

Spare parts

9.1 For 10 years from delivery of the Product, the Seller undertakes, at the request of the Buyer, to assist him in identifying spare parts for product maintenance. In any case, the Seller is in no way responsible for the failure to identify such sources.

Applicable law and multi-step clause

- 11.1 Italian law, as the Seller's law, will govern sales made on the basis of these General Conditions.
- 11.2 The Parties exclude the application of the Vienna Convention.
- 11.3 The parties will submit any disputes arising from sales made on the basis of these General Conditions to the conciliation attempt provided for by the Conciliation Service of the Milan Arbitration Chamber. In the event that the attempt fails, any disputes, even of a non-contractual nature, deriving from sales made on the basis of these General Conditions, will be resolved by arbitration according to the Rules of the Milan Arbitration Chamber, by a single arbitrator/three arbitrators, appointed in compliance with this Regulation. The Arbitration Tribunal will judge according to Italian law. The seat of the arbitration will be in Milan (Italy). The language of the arbitration will be Italian.



3-5 BELGRAVE INDUSTRIAL ESTATE, HONEYWELL LANE, OLDHAM OL8 2JP
sales@llkpizzapros.co.uk | 0161 633 5797
service@llkpizzapros.co.uk | 0161 696 0052