

# Energy Absorbing Bollards - EAB registration form

**NOTE:** Correct installation of the EAB is imperative to ensure performance under impact conditions. All installers of the EAB, **MUST** adhere to the following installation requirements and confirm in writing the installation documentation in the Roadside Services and Solutions EAB Product Manual has been strictly followed.

The following details are required:

Name of company installing the EAB: \_\_\_\_\_

Installation site: \_\_\_\_\_

Installation date:

/	/
---	---

1. "Dial Before You Dig" contacted and plans have been sourced.

Y	/	N
---	---	---

2. Service location checks carried out. Proof required.

Y	/	N
---	---	---

3. Correct reo cage installed 450mm x 800mm x 12N spiral.

Y	/	N
---	---	---

4. Concrete used is 32MPa grade @ 70mm slump.

Y	/	N
---	---	---

5. Concrete over the top of cartridge is not more than 25mm thick.

Y	/	N
---	---	---

6. Surface around EAB reinstated to customer's specifications.

Y	/	N
---	---	---

Please email signed form to: [roadside@rss.net.au](mailto:roadside@rss.net.au)

Installer's signature: \_\_\_\_\_

Print name: \_\_\_\_\_

Mobile number: \_\_\_\_\_

Email: \_\_\_\_\_

Additional comments about the installation: \_\_\_\_\_

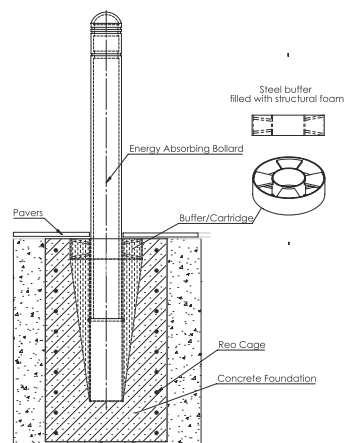

**Important Note:** Do not substitute any parts or fix any other object without first consulting Roadside Services and Solutions. Substituting any part or introducing a non-approved part may reduce the effectiveness of the Energy Absorbing Bollard and performance cannot be guaranteed.

